

GROOVING SYSTEMS

BY **GUHRING**

NEW

Boring out
Grooving
Threading
Broaching
Special tools



// FLEXIBLE
// ECONOMICAL
// ACCURATE

GUHRING

GROOVING SYSTEMS

BY **GUHRING**



GROOVING SYSTEMS

highest quality and flexibility thanks
to a vast product offering



GRINDING – INDEXABLE INSERTS AND CUTTING INSERTS

Production completed entirely on
Guhring-built grinding machines



COATING – INDEXABLE INSERTS AND CUTTING INSERTS

// In-house coating on
Guhring-built coating systems
// Latest coating technology
and coating types



MILLING/TURNING – HOLDER PRODUCTION



GUHRING'S IN-HOUSE CARBIDE PRODUCTION

Blanks – Indexable inserts and cutting inserts
Guhring-produced carbide grades



Guhring R&D for innovative tool developments

Highest quality standard world-wide

Pooled expertise under one roof

Vast product offering

Machining technology with an edge



GUHRING

Production location

Grooving tools







Dr. Jörg Gühring
President



Oliver Gühring
Sales and Marketing
Director

7000

Employees
world-wide



3500

Employees
Germany



Internal training and further
education program



International knowledge transfer thanks
to world-wide exchange program for
employees



Dietmar Pfränger

R&D, Logistics, Technical and
Production Director



Bernd Schatz

Financial and Commercial
Director



50000

Standard tools

2000

Tool types

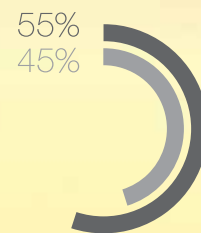

■ Standard tools
■ Special tools

Everything from one supplier – comprehensive and global

With a global network of manufacturing sites Guhring develops and produces precision tools for every major market. Customers from various industries rely on our innovative cutting tools, manufactured to the highest level of uniform quality standards across the globe.

28

PRODUCTION CENTERS

46

SUBSIDIARIES

47

SERVICE CENTRES

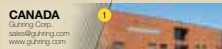

CANADA
Guhring Corp.
sales@guhring.com
www.guhring.com

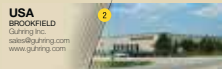

**USA
BROOKFIELD**
Guhring Inc.
sales@guhring.com
www.guhring.com

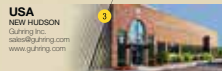

**USA
NEW HUDSON**
Guhring Inc.
sales@guhring.com
www.guhring.com



MEXICO
Guhring Mexico S.A. de C.V.
guhringmexico@guhring.com
www.guhring.com.mx



BRAZIL
Guhring Brasil
Ferrementaria Ltda.
ventas@guhringbrasil.com
www.guhring.com.br



**SOUTH
AFRICA**
Guhring Cutting Tools (Pty) Ltd.
info@guhring.co.za
www.guhring.co.za



SWEDEN
Guhring Sweden AB
info@guhring.se
www.guhring.se

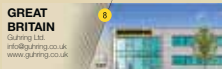

**GREAT
BRITAIN**
Guhring Ltd.
info@guhring.co.uk
www.guhring.co.uk



NETHERLANDS
N.V. Guhring S.A.
info@guhring.nl
www.guhring.nl

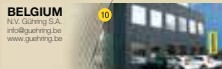

BELGIUM
N.V. Guhring S.A.
info@guhring.be
www.guhring.be



**SWITZERLAND
BOPHUSLEZ**
Guhring Schweiz AG
info@guhring.ch
www.guhring.ch



**SWITZERLAND
ALTDORF**
Guhring Messwerkzeuge GmbH
mailto:info@guhring.de
www.guhring.de

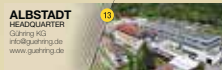

**ALBSTADT
HEADQUARTER**
Guhring KG
info@guhring.de
www.guhring.de

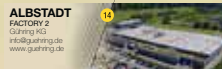

**ALBSTADT
FACTORY 2**
Guhring KG
info@guhring.de
www.guhring.de

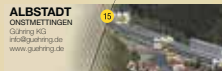

**ALBSTADT
ONSTMETTINGEN**
Guhring KG
info@guhring.de
www.guhring.de



SIGMARINGEN
Guhring KG
info@guhring.de
www.guhring.de



**RAMSTEIN-
MIESENBACH**
Guhring KG
info@guhring.de
www.guhring.de



LEVERKUSEN
Guhring KG
info@guhring.de
www.guhring.de



WEHINGEN
Guhring KG
info@guhring.de
www.guhring.de

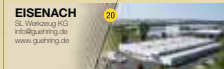

EISENACH
Guhring KG
info@guhring.de
www.guhring.de

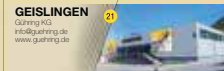

GEISLINGEN
Guhring KG
info@guhring.de
www.guhring.de



MINDELHEIM
Guhring KG
info@guhring.de
www.guhring.de



NUREMBERG
Guhring Tools
info@tools.guhring.de
www.hktools.guhring.de



REGENSBURG
Guhring KG
info@guhring.de
www.guhring.de

With innovative technologies Guhring meets specific customer requirements from process proposal to production application of precision tools – flexibly, promptly, globally. To aid in this experience, field experts across the world are available to offer on-site support at customer locations. Production, service and contact persons are available from one supplier world-wide.

In-house carbide production In-house machine construction
 In-house coating plants Highest quality standards world-wide

The world map features 30 yellow location pins, each corresponding to a callout box for a Guhring production site. The callout boxes are arranged in a grid below the map, each containing a number, a photograph of the facility, and contact information.

Location	Number	Contact Information
CHEMNITZ	25	Dr. Günting KG info@guhring.de www.guhring.de
KULMBACH	26	Günting KG service@guhring.com www.guhring.com
MARKT-ERLBACH	27	Günting KG info@guhring.de www.guhring.de
TREUEN FACTORY 1	28	Dr. Günting KG info@guhring.de www.guhring.de
TREUEN FACTORY 2	29	Dr. Günting KG info@guhring.de www.guhring.de
TREUEN FACTORY 3	30	Dr. Günting KG info@guhring.de www.guhring.de
BERLIN	31	G. Bitt Polierservice@guhring.de www.guhring.de
ZORBAU	32	Polierservice Günting GmbH info@hoffstadter-guhring.de
SPAIN	33	Günting S.A.S guhring@guhring.com www.guhring.es
ITALY UBERMERE	34	Ubermere Günting Italia s.r.l. info@ubermer.it www.ubermer.it
ITALY MESSAGLIA	35	Günting S.p.A. Unipersonale info@guhring.italy.com www.guhring.italy.com
FRANCE	36	Günting France S.A.R.L. info@guhring-france.com www.guhring-france.com
RUMANIA	37	Günting s.r.l. - Romania romania@guhring.de
HUNGARY	38	Info-Günting GmbH info@bitan.hu www.bitan.hu
AUSTRIA	39	Günting Ges.m.b.H. venice@guhring.at www.guhring.at
POLAND	40	Günting Sp. z o.o. hand@guhring.pl www.guhring.pl
CZECH REPUBLIC	41	Günting s.r.o. info@guhring.cz www.guhring.cz
DENMARK	42	Günting ApS info@guhring.dk www.guhring.dk
VIETNAM	43	Günting Vietnam LLC info@guhring.vn
THAILAND	44	Günting Thailand Co., Ltd. info.thailand@guhring.de www.guhring.co.th
INDIA	45	Günting India Pvt. Ltd. info@guhring.in www.guhring.in
CHINA	46	Günting China Sp. Ltd. hand@guhringchina.com www.guhringchina.com
TURKEY	47	Günting Turkey San. Tic. Ltd. Sti. guhring@guhring.com.tr www.guhring.com.tr
RUSSIA	48	Günting - Russland info@guhring.ru www.guhring.ru
AUSTRALIA	49	Günting Pty. Ltd. guhring@guhring.com.au www.guhring.com.au
INDONESIA	50	P.T. Günting Indonesia sales@guhring.co.id www.guhring.co.id
TAIWAN	51	Günting Taiwan Ltd. info@guhring.com.tw www.guhring.com.tw
JAPAN	52	Günting Japan Co., Ltd. info@guhring.co.jp www.guhring.co.jp
KOREA	53	Günting Korea Co., Ltd. info@guhring.co.kr www.guhring.co.kr

GROOVING SYSTEMS

Explanation of the article description

Article description System 104/106

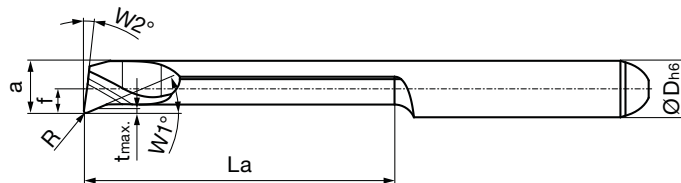

Tool description: Example: GT104.2326.010.22.30.R

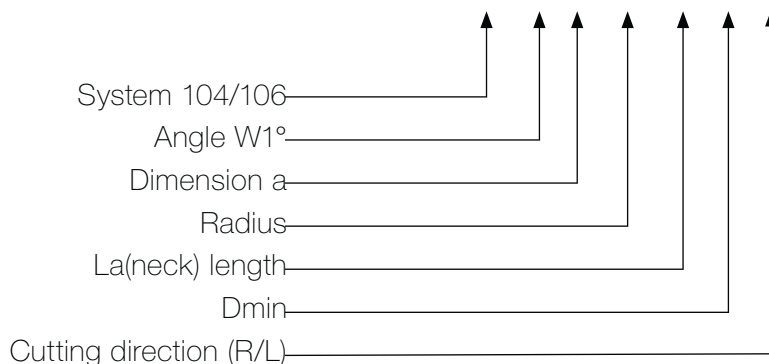

Article description System 305

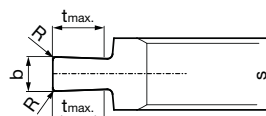
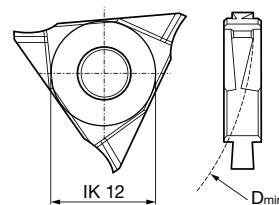

Tool description: Example: GE305.0250.020.BA.04.N

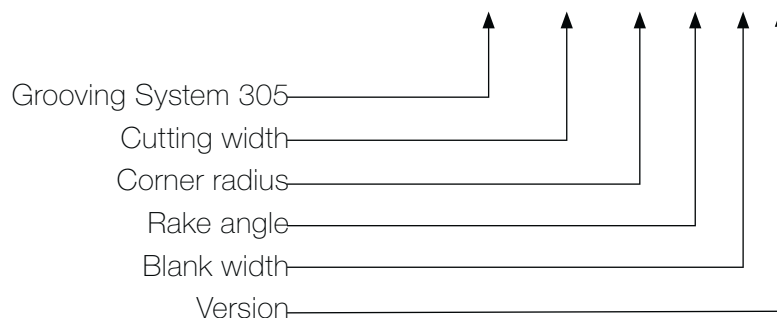

When ordering please always state the
Series no. and the Code No. i.e.:
 Article GG104.VM02.040.04.15.R,
 TiN-coated = **25164 4.001**

Ordering example

Micro-precision tools for internal threading

Cutting insert for internal threading, full profile - metric standard threads





• pitch P = 0.4-0.8

for tool holders type GH104/GB104 see from page 16

GUHRING NAVIGATOR

Cutting data page 150

Tool material	Solid carbide		
Type	GG 104	GG 104	GG 104
Surface			
	TiN	TiAlN-nanoA	bright

System 104

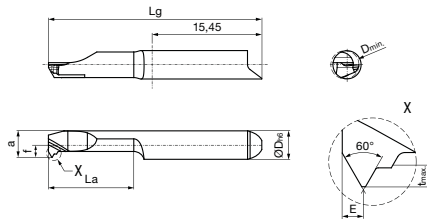

Right hand version shown
 Left hand version mirror image



Article no. **25164** **25166** **25170**

Cutting direction   

Series no.

Code no.	Description	G	P	D min	f	E	a	t max	La	Lg	D h6
			mm	mm	mm	mm	mm	mm	mm	mm	mm
4.001	GG104.VM02.040.04.15.R	M2	0.40	1.50	1.95	0.20	1.35	0.25	4.00	25.00	4.00
4.002	GG104.VM02.040.07.15.R	M2	0.40	1.50	1.95	0.20	1.35	0.25	7.00	25.00	4.00
4.003	GG104.VM02.040.12.15.R	M2	0.40	1.50	1.95	0.20	1.35	0.25	12.00	30.00	4.00
4.004	GG104.VM03.050.04.24.R	M3	0.50	2.40	1.95	0.30	1.95	0.35	4.00	25.00	4.00
4.005	GG104.VM03.050.07.24.R	M3	0.50	2.40	1.95	0.30	1.95	0.35	7.00	25.00	4.00

Code No.



GUHRING

GROOVING SYSTEMS

Highest quality and flexibility
thanks to a vast product offering.
All from one supplier.



SYSTEM 104

Micro-precision tools from Ø 0.7 mm

Tool holder.....	from page 15
Cutting inserts.....	from page 28

Broaching from Ø 1.5 mm

Tool holder.....	from page 56
Cutting inserts.....	from page 57



SYSTEM 106

Micro-precision tools from Ø 5 mm

Tool holder.....	from page 61
Cutting inserts.....	from page 74

Broaching from Ø 6 mm

Tool holder.....	from page 118
Cutting inserts.....	from page 119



SYSTEM 305

Grooving and parting off

Tool holder.....	from page 121
Indexable inserts.....	from page 137

Navigator & Technical information.....	from page 148
---	---------------

Spare Parts.....	from page 160
-------------------------	---------------

Special Solutions.....	from page 162
-------------------------------	---------------

104



SYSTEM 104

MICRO-PRECISION TOOLS



Round shank holder

from page 16



Square shank holder

from page 23



Modular holder

from page 25



Round shank holder
Broaching
page 56

Tool holder

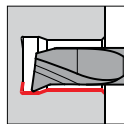

Boring out
and profiling, Type GT
from page 28

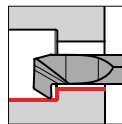

Back boring
and profiling, Type GT
from page 39

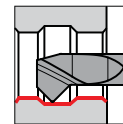

Boring out
and chamfering, Type GT
page 41

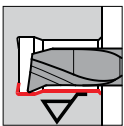

Boring out,
with Wiper, Type GJ
page 38

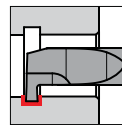

Internal grooving,
straight slots, Type GE
page 42

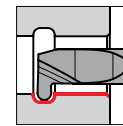

Internal grooving,
full radius slots, Type GE
page 44

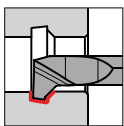

Internal pre-grooving
and chamfering, Type GV
page 45

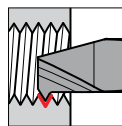

Internal threading,
Type GG
from page 51

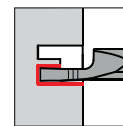

Axial grooving bores,
Type GA
from page 46

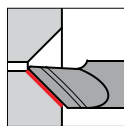

Axial chamfering
bores, Type GA
page 50

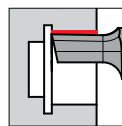

Broaching,
Type GN
from page 57

Cutting inserts from hole-Ø 0.7 mm



Round shank holder, clamping screw top

- for inserts type 104
- with internal coolant delivery

Type GB 104

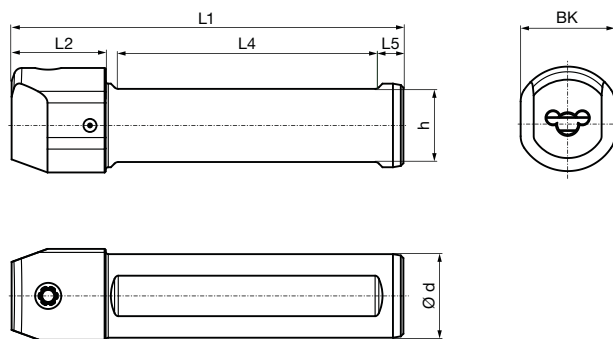

Series no. **25000**

version left and right

Code no.	Description	d	d	h	L1	L2	L4	L5	BK
		mm	inch	mm	mm	mm	mm	mm	mm
4.001	GB104.0010.075.00.15.N.IK	10.00		9.00	75.00	18.00	50.00	5.00	12.0
4.002	GB104.0012.075.00.15.N.IK	12.00		11.00	75.00	18.00	50.00	5.00	14.0
4.015	GB104.0500.354.00.15.N.IK		1/2	11.00	89.92	17.78	54.86	5.08	13.9
4.016	GB104.0625.354.00.15.N.IK		5/8	14.00	89.92	17.78	54.86	5.08	17.7
4.003	GB104.0016.075.00.15.N.IK	16.00		14.00	75.00	18.00	50.00	5.00	18.0
4.017	GB104.0750.380.00.15.N.IK		3/4	17.04	96.52	17.78	69.85	5.08	
4.004	GB104.0020.090.00.15.N.IK	20.00		18.00	90.00		55.00	5.00	
4.005	GB104.0022.090.00.15.N.IK	22.00		20.00	90.00		55.00	5.00	
4.006	GB104.0025.100.00.15.N.IK	25.00		23.00	100.00		55.00	5.00	
4.018	GB104.1000.380.00.15.N.IK		1"	23.39	96.52		69.85	5.08	

Spare parts

Series no.	Clamping screw	Tightening torque
25900		Nm
Code 6.000	M6x7.5x15IP	4-4.5

Series no.	Torx-Plus Wrench
25904	
Code 15.000	T15IP T-handle



Round shank holder, clamping screw lateral

- for inserts type 104
- with internal coolant delivery

Type GB 104

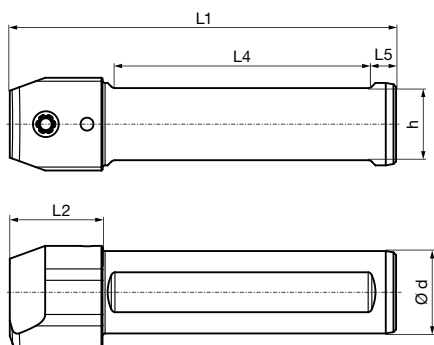

Series no. **25001**

version left and right

Code no.	Description	d	d	h	L1	L2	L4	L5
		mm	inch	mm	mm	mm	mm	mm
4.001	GB104.0010.075.00.15.N.IK.90	10.00		9.00	75.00	18.00	50.00	5.00
4.002	GB104.0012.075.00.15.N.IK.90	12.00		11.00	75.00	18.00	50.00	5.00
4.015	GB104.0500.354.00.15.N.IK.90		1/2	11.00	89.92	17.78	54.86	5.08
4.016	GB104.0625.354.00.15.N.IK.90		5/8	14.00	89.92	17.78	54.86	5.08
4.003	GB104.0016.075.00.15.N.IK.90	16.00		14.00	75.00	18.00	50.00	5.00
4.017	GB104.0750.380.00.15.N.IK.90		3/4	17.04	96.52	17.78	69.85	5.08
4.004	GB104.0020.090.00.15.N.IK.90	20.00		18.00	90.00		55.00	5.00
4.005	GB104.0022.090.00.15.N.IK.90	22.00		20.00	90.00		55.00	5.00
4.006	GB104.0025.100.00.15.N.IK.90	25.00		23.00	100.00		55.00	5.00
4.018	GB104.1000.380.00.15.N.IK.90		1"	23.39	96.52		69.85	5.08

Spare parts

Series no.	Clamping screw	Tightening torque
25900		Nm
Code 6.000	M6x7.5x15IP	4-4.5

Series no.	Torx-Plus Wrench
25904	
Code 15.000	T15IP T-handle



Round shank holder, clamping screw above, four clamping surfaces

- for inserts type 104
- with internal coolant delivery

Type GB 104

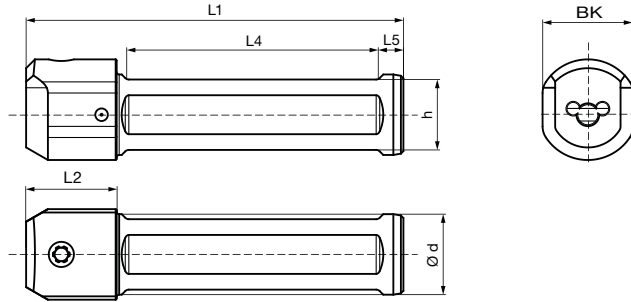

Series no. **25018**

version left and right

Code no.	Description	d	h	L1	L2	L4	L5	BK
		mm	mm	mm	mm	mm	mm	mm
4.010	GB104.0016.075.00.15.N.IK.VSP	16.00	14.00	75.00	18.00	50.00	5.00	18.0
4.020	GB104.0020.090.00.15.N.IK.VSP	20.00	18.00	90.00		55.00	5.00	
4.030	GB104.0022.090.00.15.N.IK.VSP	22.00	20.00	90.00		55.00	5.00	
4.040	GB104.0025.100.00.15.N.IK.VSP	25.00	23.00	100.00		55.00	5.00	

Spare parts

Series no.	Clamping screw	Tightening torque
25900		Nm
Code 6.000	M6x7.5x15IP	4-4.5

Series no.	Torx-Plus Wrench
25904	
Code 15.000	T15IP T-handle



Round shank holder, clamping screw above, without clamping surfaces

- for inserts type 104
- with internal coolant delivery

Type GB 104

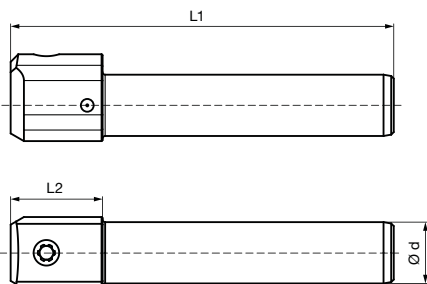

Series no. **25017**

version left and right

Code no.	Description	d	L1	L2	BK
		mm	mm	mm	mm
4.010	GB104.0010.075.00.15.N.IK.RND	10.00	75.00	18.00	12.0
4.020	GB104.0012.075.00.15.N.IK.RND	12.00	75.00	18.00	14.0
4.030	GB104.0016.075.00.15.N.IK.RND	16.00	75.00	18.00	18.0

Spare parts

Series no.	Clamping screw	Tightening torque
25900		Nm
Code 6.000	M6x7.5x15IP	4-4.5

Series no.	Torx-Plus Wrench
25904	
Code 15.000	T15IP T-handle

**Round shank holder, clamping screw above, for Citizen machine**

- for inserts type 104
- with internal coolant delivery

Type GB 104

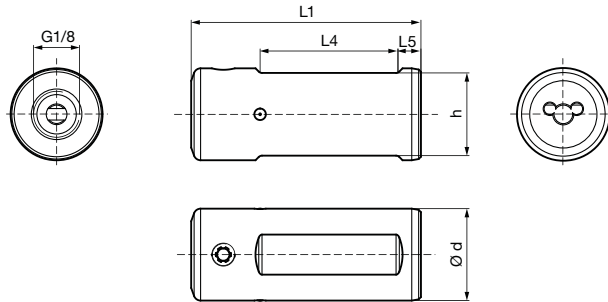
Series no. **25021**

version left and right

Code no.	Description	d	d	h	L1	L4	L5
		mm	inch	mm	mm	mm	mm
4.110	GB104.0750.040.00.15.N.IK.CIT		3/4	17.04	40.00	20.32	5.08
4.120	GB104.0750.050.00.15.N.IK.CIT		3/4	17.04	50.00	31.75	5.08
4.130	GB104.0750.070.00.15.N.IK.CIT		3/4	17.04	70.00	44.45	5.08
4.140	GB104.0750.100.00.15.N.IK.CIT		3/4	17.04	100.00	76.20	5.08
4.010	GB104.0020.050.00.15.N.IK.CIT	20.00		18.00	50.00	30.00	5.00
4.020	GB104.0020.030.00.15.N.IK.CIT	20.00		18.00	30.00	13.00	5.00
4.150	GB104.1000.060.00.15.N.IK.CIT		1"	23.39	60.00	38.10	5.08
4.160	GB104.1000.100.00.15.N.IK.CIT		1"	23.39	100.00	76.20	5.08

Spare parts

Series no.	Clamping screw	Tightening torque
25900		Nm
Code 6.000	M6x7.5x15IP	4-4.5

Series no.	Torx-Plus Wrench
25904	
Code 15.000	T15IP T-handle

Round shank holder, clamping screw above, for Star machine

- for inserts type 104
- with internal coolant delivery

Type GB 104

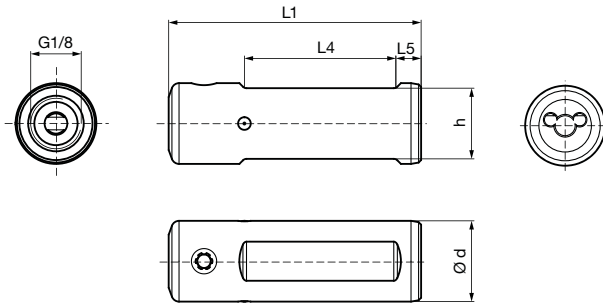
Series no. **25022**

version left and right

Code no.	Description	d	h	L1	L4	L5
		mm	mm	mm	mm	mm
4.010	GB104.0016.030.00.15.N.IK.STA	16.00	14.00	30.00	13.00	5.00
4.020	GB104.0016.050.00.15.N.IK.STA	16.00	14.00	50.00	30.00	5.00
4.030	GB104.0016.070.00.15.N.IK.STA	16.00	14.00	70.00	50.00	5.00
4.040	GB104.0022.038.00.15.N.IK.STA	22.00	20.00	38.00	18.00	5.00
4.050	GB104.0022.050.00.15.N.IK.STA	22.00	20.00	50.00	30.00	5.00
4.060	GB104.0022.070.00.15.N.IK.STA	22.00	20.00	70.00	50.00	5.00
4.070	GB104.0022.100.00.15.N.IK.STA	22.00	20.00	100.00	80.00	5.00
4.080	GB104.0022.120.00.15.N.IK.STA	22.00	20.00	120.00	100.00	5.00

Spare parts

Series no.	Clamping screw	Tightening torque
25900		Nm
Code 6.000	M6x7.5x15IP	4-4.5

Series no.	Torx-Plus Wrench
25904	
Code 15.000	T15IP T-handle



Round shank holder, clamping screw above, for Tornos machine

- for inserts type 104
- with internal coolant delivery

Type GB 104

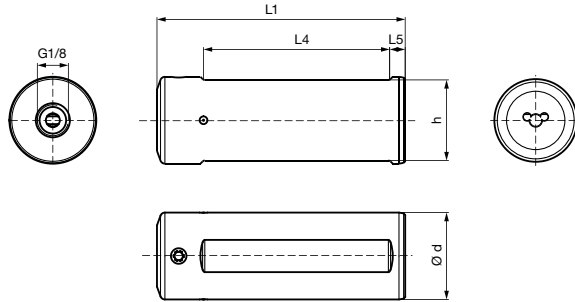

Series no. **25023**
version left and right

Code no.	Description	d	h	L1	L4	L5
		mm	mm	mm	mm	mm
4.010	GB104.0018.310.00.15.N.IK.TOR	18.00	16.00	310.00	290.00	5.00
4.020	GB104.0020.170.00.15.N.IK.TOR	20.00	18.00	170.00	150.00	5.00
4.030	GB104.0020.185.00.15.N.IK.TOR	20.00	18.00	185.00	165.00	5.00
4.040	GB104.0025.100.00.15.N.IK.TOR	25.00	23.00	100.00	80.00	5.00
4.050	GB104.0025.150.00.15.N.IK.TOR	25.00	23.00	150.00	130.00	5.00
4.060	GB104.0028.080.00.15.N.IK.TOR	28.00	26.00	80.00	60.00	5.00

Spare parts

Series no.	Clamping screw	Tightening torque
25900		Nm
Code 6.000	M6x7.5x15IP	4-4.5

Series no.	Torx-Plus Wrench
25904	
Code 15.000	T15IP T-handle



Square shank holder, 90° offset

- for inserts type 104
- without internal coolant delivery

Type GH 104

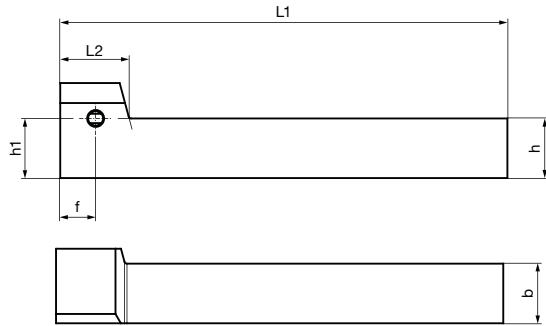

Right hand version shown
Left hand version mirror image

Series no. **25002**

version right-hand

Code no.	Description	b	b	h	h1	f	L1	L2
		mm	inch	mm	mm	mm	mm	mm
4.001	GH104.0808.090.90.15.R	8.00		8.00	8.00	9.50	90.00	18.50
4.010	GH104.0375.350.90.15.R		3/8	9.52	9.52	7.62	88.90	16.51
4.002	GH104.1010.090.90.15.R	10.00		10.00	10.00	9.50	90.00	18.50
4.003	GH104.1212.090.90.15.R	12.00		12.00	12.00	9.50	90.00	18.50
4.011	GH104.0500.350.90.15.R		1/2	12.70	12.70	7.62	88.90	16.51
4.012	GH104.0625.400.90.15.R		5/8	15.87	15.87	7.62	101.60	16.51
4.004	GH104.1616.120.90.15.R	16.00		16.00	16.00	9.50	120.00	18.50

Series no. **25003**

version left-hand

Code no.	Description	b	b	h	h1	f	L1	L2
		mm	inch	mm	mm	mm	mm	mm
4.001	GH104.0808.090.90.15.L	8.00		8.00	8.00	9.50	90.00	18.50
4.010	GH104.0375.350.90.15.L		3/8	9.52	9.52	7.62	88.90	16.51
4.002	GH104.1010.090.90.15.L	10.00		10.00	10.00	9.50	90.00	18.50
4.003	GH104.1212.090.90.15.L	12.00		12.00	12.00	9.50	90.00	18.50
4.011	GH104.0500.350.90.15.L		1/2	12.70	12.70	7.62	88.90	16.51
4.012	GH104.0625.400.90.15.L		5/8	15.87	15.87	7.62	101.60	16.51
4.004	GH104.1616.120.90.15.L	16.00		16.00	16.00	9.50	120.00	18.50

Spare parts

Series no.	Clamping screw	Tightening torque
25900		Nm
Code 6.000	M6x7.5x15IP	4-4.5

Series no.	Torx-Plus Wrench
25904	
Code 15.000	T15IP T-handle



Square shank holder, straight 0°

- for inserts type 104
- without internal coolant delivery

Type GH 104

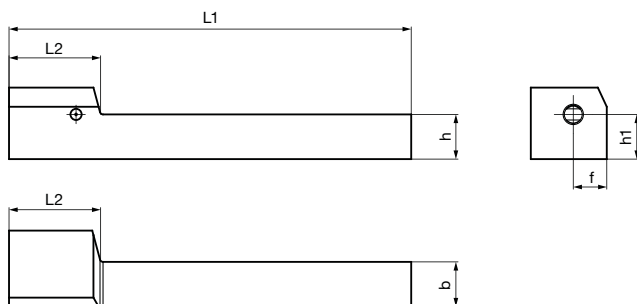

Right hand version shown
Left hand version mirror image



Series no. **25019**

version right-hand

Code no.	Description	b mm	b inch	h mm	h1 mm	f mm	L1 mm	L2 mm
4.010	GH104.0808.090.00.15.R	8.00		8.00	8.00	7.50	90.00	20.50
4.100	GH104.0375.350.00.15.R		3/8	9.52	9.52	7.62	88.90	20.00
4.020	GH104.1010.090.00.15.R	10.00		10.00	10.00	7.50	90.00	20.50
4.030	GH104.1212.090.00.15.R	12.00		12.00	12.00	7.50	90.00	20.50
4.110	GH104.0500.350.00.15.R		1/2	12.70	12.70	7.62	88.90	20.00
4.120	GH104.0625.400.00.15.R		5/8	15.87	15.87	7.62	101.60	20.00
4.040	GH104.1616.100.00.15.R	16.00		16.00	16.00	7.50	100.00	20.50

Series no. **25020**

version left-hand

Code no.	Description	b mm	b inch	h mm	h1 mm	f mm	L1 mm	L2 mm
4.010	GH104.0808.090.00.15.L	8.00		8.00	8.00	7.50	90.00	20.50
4.100	GH104.0375.350.00.15.L		3/8	9.52	9.52	7.62	88.90	20.00
4.020	GH104.1010.090.00.15.L	10.00		10.00	10.00	7.50	90.00	20.50
4.030	GH104.1212.090.00.15.L	12.00		12.00	12.00	7.50	90.00	20.50
4.110	GH104.0500.350.00.15.L		1/2	12.70	12.70	7.62	88.90	20.00
4.120	GH104.0625.400.00.15.L		5/8	15.87	15.87	7.62	101.60	20.00
4.040	GH104.1616.100.00.15.L	16.00		16.00	16.00	7.50	100.00	20.50

Spare parts

Series no.	Clamping screw	Tightening torque
25900		Nm
Code 6.000	M6x7.5x15IP	4-4.5

Series no.	Torx-Plus Wrench
25904	
Code 15.000	T15IP T-handle



Polygon shank holder, to ISO 26623, straight 0°

- for inserts type 104
- with internal coolant delivery

Type GH 104

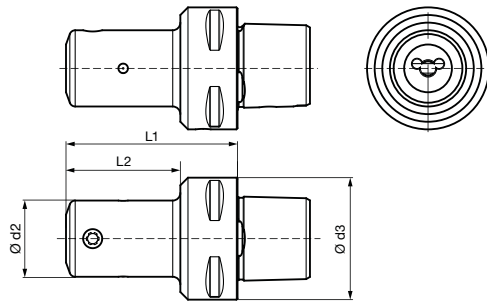

Series no. **25010**

version left and right

Code no.	Description	d2	d3	L1	L2
		mm		mm	mm
4.001	GH104.PO32.045.00.15.N.IK	20.00	PSC 32	45.00	30.00
4.002	GH104.PO40.050.00.15.N.IK	20.00	PSC 40	50.00	30.00
4.003	GH104.PO50.050.00.15.N.IK	20.00	PSC 50	50.00	30.00
4.004	GH104.PO63.052.00.15.N.IK	20.00	PSC 63	52.00	30.00

Spare parts

Series no.	Clamping screw	Tightening torque
25900		Nm
Code 6.000	M6x7.5x15IP	4-4.5

Series no.	Torx-Plus Wrench
25904	
Code 15.000	T15IP T-handle



Polygon shank holder, to ISO 26623, off-set 90°

- for inserts type 104
- with internal coolant delivery

Type GH 104

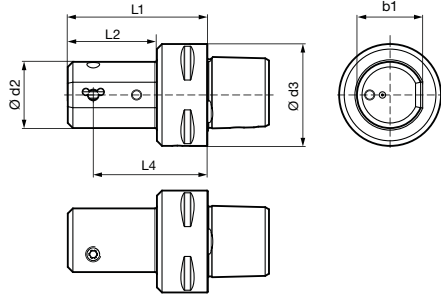

Right hand version shown
Left hand version mirror image

Series no. **25012**
version right-hand

Code no.	Description	d2	d3	L1	L2	L4	b1
		mm		mm	mm	mm	mm
4.001	GH104.PO32.045.90.15.R.IK	26.00	PSC 32	55.00	40.00	45.00	25.00
4.002	GH104.PO40.050.90.15.R.IK	26.00	PSC 40	55.00	35.00	45.00	25.00
4.003	GH104.PO50.050.90.15.R.IK	26.00	PSC 50	55.00	35.00	45.00	25.00
4.004	GH104.PO63.052.90.15.R.IK	26.00	PSC 63	55.00	33.00	45.00	25.00

Series no. **25013**
version left-hand

Code no.	Description	d2	d3	L1	L2	L4	b1
		mm		mm	mm	mm	mm
4.001	GH104.PO32.045.90.15.L.IK	26.00	PSC 32	55.00	40.00	45.00	25.00
4.002	GH104.PO40.050.90.15.L.IK	26.00	PSC 40	55.00	35.00	45.00	25.00
4.003	GH104.PO50.050.90.15.L.IK	26.00	PSC 50	55.00	35.00	45.00	25.00
4.004	GH104.PO63.052.90.15.L.IK	26.00	PSC 63	55.00	33.00	45.00	25.00

Spare parts

Series no.	Clamping screw	Tightening torque
25900		Nm
Code 6.000	M6x7.5x15IP	4-4.5

Series no.	Torx-Plus Wrench
25904	
Code 15.000	T15IP T-handle



HSK-T holder, to ISO 12164-3, straight 0°

- for inserts type 104
- with internal coolant delivery

Type GH 104

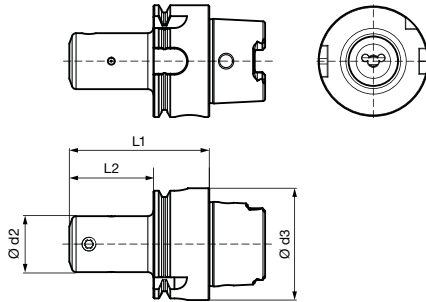

Series no. **25016**

version left and right

Code no.	Description	d2	d3	L1	L2
		mm		mm	mm
4.001	GH104.HS40.050.00.15.N.IK	20.00	HSK-T 40	50.00	30.00
4.002	GH104.HS63.056.00.15.N.IK	20.00	HSK-T 63	56.00	30.00

Spare parts

Series no.	Clamping screw	Tightening torque
25900		Nm
Code 6.000	M6x7.5x15IP	4-4.5

Series no.	Torx-Plus Wrench
25904	
Code 15.000	T15IP T-handle



Cutting insert for boring out and profiling

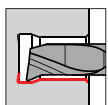

• radial free 23°

for tool holders type GH104/GB104 see from page 16

Cutting data page 148

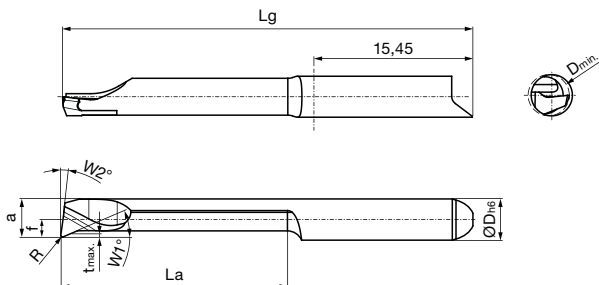

Right hand version shown
Left hand version mirror image

Tool material	Solid carbide		
Type	GT 104	GT 104	GT 104
Surface	S	a	○
	TiN	TiAlN-nanoA	bright



Code no.	Description	D min mm	R mm	W1 °	W2 °	f mm	a mm	t max mm	La mm	Lg mm	D h6 mm	Series no.		
												25050	25052	25056
												Cutting direction		
												R	R	R
4.001	GT104.2306.005.03.07.R	0.70	0.05	23	8	1.95	0.60	0.05	3.00	25.00	4.00			
4.002	GT104.2309.005.04.10.R	1.00	0.05	23	8	1.95	0.90	0.10	4.00	25.00	4.00			
4.003	GT104.2309.005.07.10.R	1.00	0.05	23	8	1.95	0.90	0.10	7.00	25.00	4.00			
4.004	GT104.2314.005.04.15.R	1.50	0.05	23	8	1.95	1.40	0.15	4.00	25.00	4.00			
4.007	GT104.2314.010.04.15.R	1.50	0.10	23	8	1.95	1.40	0.15	4.00	25.00	4.00			
4.005	GT104.2314.005.07.15.R	1.50	0.05	23	8	1.95	1.40	0.15	7.00	25.00	4.00			
4.008	GT104.2314.010.07.15.R	1.50	0.10	23	8	1.95	1.40	0.15	7.00	25.00	4.00			
4.006	GT104.2314.005.12.15.R	1.50	0.05	23	8	1.95	1.40	0.15	12.00	30.00	4.00			
4.009	GT104.2314.010.12.15.R	1.50	0.10	23	8	1.95	1.40	0.15	12.00	30.00	4.00			
4.010	GT104.2319.005.04.20.R	2.00	0.05	23	8	1.95	1.90	0.15	4.00	25.00	4.00			
4.014	GT104.2319.010.04.20.R	2.00	0.10	23	8	1.95	1.90	0.15	4.00	25.00	4.00			
4.018	GT104.2319.015.04.20.R	2.00	0.15	23	8	1.95	1.90	0.15	4.00	25.00	4.00			
4.011	GT104.2319.005.07.20.R	2.00	0.05	23	8	1.95	1.90	0.15	7.00	25.00	4.00			
4.015	GT104.2319.010.07.20.R	2.00	0.10	23	8	1.95	1.90	0.15	7.00	25.00	4.00			
4.019	GT104.2319.015.07.20.R	2.00	0.15	23	8	1.95	1.90	0.15	7.00	25.00	4.00			
4.012	GT104.2319.005.12.20.R	2.00	0.05	23	8	1.95	1.90	0.15	12.00	30.00	4.00			
4.016	GT104.2319.010.12.20.R	2.00	0.10	23	8	1.95	1.90	0.15	12.00	30.00	4.00			
4.020	GT104.2319.015.12.20.R	2.00	0.15	23	8	1.95	1.90	0.15	12.00	30.00	4.00			
4.013	GT104.2319.005.17.20.R	2.00	0.05	23	8	1.95	1.90	0.15	17.00	35.00	4.00			
4.017	GT104.2319.010.17.20.R	2.00	0.10	23	8	1.95	1.90	0.15	17.00	35.00	4.00			
4.021	GT104.2319.015.17.20.R	2.00	0.15	23	8	1.95	1.90	0.15	17.00	35.00	4.00			
4.022	GT104.2326.005.07.30.R	3.00	0.05	23	8	1.95	2.60	0.20	7.00	25.00	4.00			
4.026	GT104.2326.010.07.30.R	3.00	0.10	23	8	1.95	2.60	0.20	7.00	25.00	4.00			
4.030	GT104.2326.020.07.30.R	3.00	0.20	23	8	1.95	2.60	0.20	7.00	25.00	4.00			
4.023	GT104.2326.005.12.30.R	3.00	0.05	23	8	1.95	2.60	0.20	12.00	30.00	4.00			
4.027	GT104.2326.010.12.30.R	3.00	0.10	23	8	1.95	2.60	0.20	12.00	30.00	4.00			
4.031	GT104.2326.020.12.30.R	3.00	0.20	23	8	1.95	2.60	0.20	12.00	30.00	4.00			
4.024	GT104.2326.005.17.30.R	3.00	0.05	23	8	1.95	2.60	0.20	17.00	35.00	4.00			
4.028	GT104.2326.010.17.30.R	3.00	0.10	23	8	1.95	2.60	0.20	17.00	35.00	4.00			
4.032	GT104.2326.020.17.30.R	3.00	0.20	23	8	1.95	2.60	0.20	17.00	35.00	4.00			
4.025	GT104.2326.005.22.30.R	3.00	0.05	23	8	1.95	2.60	0.20	22.00	40.00	4.00			
4.029	GT104.2326.010.22.30.R	3.00	0.10	23	8	1.95	2.60	0.20	22.00	40.00	4.00			
4.033	GT104.2326.020.22.30.R	3.00	0.20	23	8	1.95	2.60	0.20	22.00	40.00	4.00			
4.034	GT104.2337.005.12.40.R	4.00	0.05	23	8	1.70	3.70	0.30	12.00	30.00	4.00			
4.039	GT104.2337.015.12.40.R	4.00	0.15	23	8	1.70	3.70	0.30	12.00	30.00	4.00			
4.044	GT104.2337.025.12.40.R	4.00	0.25	23	8	1.70	3.70	0.30	12.00	30.00	4.00			
4.035	GT104.2337.005.17.40.R	4.00	0.05	23	8	1.70	3.70	0.30	17.00	35.00	4.00			
4.040	GT104.2337.015.17.40.R	4.00	0.15	23	8	1.70	3.70	0.30	17.00	35.00	4.00			
4.045	GT104.2337.025.17.40.R	4.00	0.25	23	8	1.70	3.70	0.30	17.00	35.00	4.00			
4.036	GT104.2337.005.22.40.R	4.00	0.05	23	8	1.70	3.70	0.30	22.00	40.00	4.00			



Series no. 25050 25052 25056											
Cutting direction (R) (R) (R)											
Code no.	Description	D min	R	W1	W2	f	a	t max	La	Lg	D h6
		mm	mm	°	°	mm	mm	mm	mm	mm	mm
4.041	GT104.2337.015.22.40.R	4.00	0.15	23	8	1.70	3.70	0.30	22.00	40.00	4.00
4.046	GT104.2337.025.22.40.R	4.00	0.25	23	8	1.70	3.70	0.30	22.00	40.00	4.00
4.037	GT104.2337.005.27.40.R	4.00	0.05	23	8	1.70	3.70	0.30	27.00	45.00	4.00
4.042	GT104.2337.015.27.40.R	4.00	0.15	23	8	1.70	3.70	0.30	27.00	45.00	4.00
4.047	GT104.2337.025.27.40.R	4.00	0.25	23	8	1.70	3.70	0.30	27.00	45.00	4.00
4.038	GT104.2337.005.32.40.R	4.00	0.05	23	8	1.70	3.70	0.30	32.00	50.00	4.00
4.043	GT104.2337.015.32.40.R	4.00	0.15	23	8	1.70	3.70	0.30	32.00	50.00	4.00
4.048	GT104.2337.025.32.40.R	4.00	0.25	23	8	1.70	3.70	0.30	32.00	50.00	4.00

Series no. 25051 25053 25057											
Cutting direction (L) (L) (L)											
Code no.	Description	D min	R	W1	W2	f	a	t max	La	Lg	D h6
		mm	mm	°	°	mm	mm	mm	mm	mm	mm
4.001	GT104.2306.005.03.07.L	0.70	0.05	23	8	1.95	0.60	0.05	3.00	25.00	4.00
4.002	GT104.2309.005.04.10.L	1.00	0.05	23	8	1.95	0.90	0.10	4.00	25.00	4.00
4.003	GT104.2309.005.07.10.L	1.00	0.05	23	8	1.95	0.90	0.10	7.00	25.00	4.00
4.004	GT104.2314.005.04.15.L	1.50	0.05	23	8	1.95	1.40	0.15	4.00	25.00	4.00
4.007	GT104.2314.010.04.15.L	1.50	0.10	23	8	1.95	1.40	0.15	4.00	25.00	4.00
4.005	GT104.2314.005.07.15.L	1.50	0.05	23	8	1.95	1.40	0.15	7.00	25.00	4.00
4.008	GT104.2314.010.07.15.L	1.50	0.10	23	8	1.95	1.40	0.15	7.00	25.00	4.00
4.006	GT104.2314.005.12.15.L	1.50	0.05	23	8	1.95	1.40	0.15	12.00	30.00	4.00
4.009	GT104.2314.010.12.15.L	1.50	0.10	23	8	1.95	1.40	0.15	12.00	30.00	4.00
4.010	GT104.2319.005.04.20.L	2.00	0.05	23	8	1.95	1.90	0.15	4.00	25.00	4.00
4.014	GT104.2319.010.04.20.L	2.00	0.10	23	8	1.95	1.90	0.15	4.00	25.00	4.00
4.018	GT104.2319.015.04.20.L	2.00	0.15	23	8	1.95	1.90	0.15	4.00	25.00	4.00
4.011	GT104.2319.005.07.20.L	2.00	0.05	23	8	1.95	1.90	0.15	7.00	25.00	4.00
4.015	GT104.2319.010.07.20.L	2.00	0.10	23	8	1.95	1.90	0.15	7.00	25.00	4.00
4.019	GT104.2319.015.07.20.L	2.00	0.15	23	8	1.95	1.90	0.15	7.00	25.00	4.00
4.012	GT104.2319.005.12.20.L	2.00	0.05	23	8	1.95	1.90	0.15	12.00	30.00	4.00
4.016	GT104.2319.010.12.20.L	2.00	0.10	23	8	1.95	1.90	0.15	12.00	30.00	4.00
4.020	GT104.2319.015.12.20.L	2.00	0.15	23	8	1.95	1.90	0.15	12.00	30.00	4.00
4.013	GT104.2319.005.17.20.L	2.00	0.05	23	8	1.95	1.90	0.15	17.00	35.00	4.00
4.017	GT104.2319.010.17.20.L	2.00	0.10	23	8	1.95	1.90	0.15	17.00	35.00	4.00
4.021	GT104.2319.015.17.20.L	2.00	0.15	23	8	1.95	1.90	0.15	17.00	35.00	4.00
4.022	GT104.2326.005.07.30.L	3.00	0.05	23	8	1.95	2.60	0.20	7.00	25.00	4.00
4.026	GT104.2326.010.07.30.L	3.00	0.10	23	8	1.95	2.60	0.20	7.00	25.00	4.00
4.030	GT104.2326.020.07.30.L	3.00	0.20	23	8	1.95	2.60	0.20	7.00	25.00	4.00
4.023	GT104.2326.005.12.30.L	3.00	0.05	23	8	1.95	2.60	0.20	12.00	30.00	4.00
4.027	GT104.2326.010.12.30.L	3.00	0.10	23	8	1.95	2.60	0.20	12.00	30.00	4.00
4.031	GT104.2326.020.12.30.L	3.00	0.20	23	8	1.95	2.60	0.20	12.00	30.00	4.00
4.024	GT104.2326.005.17.30.L	3.00	0.05	23	8	1.95	2.60	0.20	17.00	35.00	4.00
4.028	GT104.2326.010.17.30.L	3.00	0.10	23	8	1.95	2.60	0.20	17.00	35.00	4.00
4.032	GT104.2326.020.17.30.L	3.00	0.20	23	8	1.95	2.60	0.20	17.00	35.00	4.00
4.025	GT104.2326.005.22.30.L	3.00	0.05	23	8	1.95	2.60	0.20	22.00	40.00	4.00
4.029	GT104.2326.010.22.30.L	3.00	0.10	23	8	1.95	2.60	0.20	22.00	40.00	4.00
4.033	GT104.2326.020.22.30.L	3.00	0.20	23	8	1.95	2.60	0.20	22.00	40.00	4.00
4.034	GT104.2337.005.12.40.L	4.00	0.05	23	8	1.70	3.70	0.30	12.00	30.00	4.00
4.039	GT104.2337.015.12.40.L	4.00	0.15	23	8	1.70	3.70	0.30	12.00	30.00	4.00
4.044	GT104.2337.025.12.40.L	4.00	0.25	23	8	1.70	3.70	0.30	12.00	30.00	4.00
4.035	GT104.2337.005.17.40.L	4.00	0.05	23	8	1.70	3.70	0.30	17.00	35.00	4.00
4.040	GT104.2337.015.17.40.L	4.00	0.15	23	8	1.70	3.70	0.30	17.00	35.00	4.00
4.045	GT104.2337.025.17.40.L	4.00	0.25	23	8	1.70	3.70	0.30	17.00	35.00	4.00
4.036	GT104.2337.005.22.40.L	4.00	0.05	23	8	1.70	3.70	0.30	22.00	40.00	4.00
4.041	GT104.2337.015.22.40.L	4.00	0.15	23	8	1.70	3.70	0.30	22.00	40.00	4.00
4.046	GT104.2337.025.22.40.L	4.00	0.25	23	8	1.70	3.70	0.30	22.00	40.00	4.00
4.037	GT104.2337.005.27.40.L	4.00	0.05	23	8	1.70	3.70	0.30	27.00	45.00	4.00
4.042	GT104.2337.015.27.40.L	4.00	0.15	23	8	1.70	3.70	0.30	27.00	45.00	4.00
4.047	GT104.2337.025.27.40.L	4.00	0.25	23	8	1.70	3.70	0.30	27.00	45.00	4.00
4.038	GT104.2337.005.32.40.L	4.00	0.05	23	8	1.70	3.70	0.30	32.00	50.00	4.00
4.043	GT104.2337.015.32.40.L	4.00	0.15	23	8	1.70	3.70	0.30	32.00	50.00	4.00
4.048	GT104.2337.025.32.40.L	4.00	0.25	23	8	1.70	3.70	0.30	32.00	50.00	4.00



Cutting insert for boring out and profiling

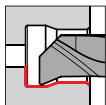

• face flat 90°

for tool holders type GH104/GB104 see from page 16

Cutting data page 148

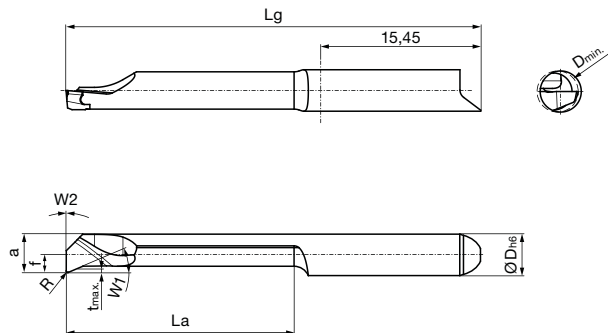

Right hand version shown
Left hand version mirror image

Tool material	Solid carbide		
Type	GT 104	GT 104	GT 104
Surface	S	a	○
	TiN	TiAlN-nanoA	bright



		Series no.			Cutting direction												
		25058	25060	25064	(R)	(R)	(R)	D min	R	W1	W2	f	a	t max	La	Lg	D h6
Code no.	Description	mm	mm	mm	°	°	mm	mm	mm	°	°	mm	mm	mm	mm	mm	mm
4.001	GT104.9006.005.03.07.R	0.70	0.05	23	0	1.95	0.60	0.05	3.00	25.00	4.00						
4.002	GT104.9009.005.04.10.R	1.00	0.05	23	0	1.95	0.90	0.10	4.00	25.00	4.00						
4.003	GT104.9009.005.07.10.R	1.00	0.05	23	0	1.95	0.90	0.10	7.00	25.00	4.00						
4.004	GT104.9014.005.04.15.R	1.50	0.05	23	0	1.95	1.40	0.15	4.00	25.00	4.00						
4.007	GT104.9014.010.04.15.R	1.50	0.10	23	0	1.95	1.40	0.15	4.00	25.00	4.00						
4.005	GT104.9014.005.07.15.R	1.50	0.05	23	0	1.95	1.40	0.15	7.00	25.00	4.00						
4.008	GT104.9014.010.07.15.R	1.50	0.10	23	0	1.95	1.40	0.15	7.00	25.00	4.00						
4.006	GT104.9014.005.12.15.R	1.50	0.05	23	0	1.95	1.40	0.15	12.00	30.00	4.00						
4.009	GT104.9014.010.12.15.R	1.50	0.10	23	0	1.95	1.40	0.15	12.00	30.00	4.00						
4.010	GT104.9019.005.04.20.R	2.00	0.05	23	0	1.95	1.90	0.15	4.00	25.00	4.00						
4.014	GT104.9019.010.04.20.R	2.00	0.10	23	0	1.95	1.90	0.15	4.00	25.00	4.00						
4.018	GT104.9019.015.04.20.R	2.00	0.15	23	0	1.95	1.90	0.15	4.00	25.00	4.00						
4.011	GT104.9019.005.07.20.R	2.00	0.05	23	0	1.95	1.90	0.15	7.00	25.00	4.00						
4.015	GT104.9019.010.07.20.R	2.00	0.10	23	0	1.95	1.90	0.15	7.00	25.00	4.00						
4.019	GT104.9019.015.07.20.R	2.00	0.15	23	0	1.95	1.90	0.15	7.00	25.00	4.00						
4.012	GT104.9019.005.12.20.R	2.00	0.05	23	0	1.95	1.90	0.15	12.00	30.00	4.00						
4.016	GT104.9019.010.12.20.R	2.00	0.10	23	0	1.95	1.90	0.15	12.00	30.00	4.00						
4.020	GT104.9019.015.12.20.R	2.00	0.15	23	0	1.95	1.90	0.15	12.00	30.00	4.00						
4.013	GT104.9019.005.17.20.R	2.00	0.05	23	0	1.95	1.90	0.15	17.00	35.00	4.00						
4.017	GT104.9019.010.17.20.R	2.00	0.10	23	0	1.95	1.90	0.15	17.00	35.00	4.00						
4.021	GT104.9019.015.17.20.R	2.00	0.15	23	0	1.95	1.90	0.15	17.00	35.00	4.00						
4.022	GT104.9026.005.07.30.R	3.00	0.05	23	0	1.95	2.60	0.20	7.00	25.00	4.00						
4.026	GT104.9026.010.07.30.R	3.00	0.10	23	0	1.95	2.60	0.20	7.00	25.00	4.00						
4.030	GT104.9026.020.07.30.R	3.00	0.20	23	0	1.95	2.60	0.20	7.00	25.00	4.00						
4.023	GT104.9026.005.12.30.R	3.00	0.05	23	0	1.95	2.60	0.20	12.00	30.00	4.00						
4.027	GT104.9026.010.12.30.R	3.00	0.10	23	0	1.95	2.60	0.20	12.00	30.00	4.00						
4.031	GT104.9026.020.12.30.R	3.00	0.20	23	0	1.95	2.60	0.20	12.00	30.00	4.00						
4.024	GT104.9026.005.17.30.R	3.00	0.05	23	0	1.95	2.60	0.20	17.00	35.00	4.00						
4.028	GT104.9026.010.17.30.R	3.00	0.10	23	0	1.95	2.60	0.20	17.00	35.00	4.00						
4.032	GT104.9026.020.17.30.R	3.00	0.20	23	0	1.95	2.60	0.20	17.00	35.00	4.00						
4.025	GT104.9026.005.22.30.R	3.00	0.05	23	0	1.95	2.60	0.20	22.00	40.00	4.00						
4.029	GT104.9026.010.22.30.R	3.00	0.10	23	0	1.95	2.60	0.20	22.00	40.00	4.00						
4.033	GT104.9026.020.22.30.R	3.00	0.20	23	0	1.95	2.60	0.20	22.00	40.00	4.00						
4.034	GT104.9037.005.12.40.R	4.00	0.05	23	0	1.70	3.70	0.30	12.00	30.00	4.00						
4.039	GT104.9037.015.12.40.R	4.00	0.15	23	0	1.70	3.70	0.30	12.00	30.00	4.00						
4.044	GT104.9037.025.12.40.R	4.00	0.25	23	0	1.70	3.70	0.30	12.00	30.00	4.00						
4.035	GT104.9037.005.17.40.R	4.00	0.05	23	0	1.70	3.70	0.30	17.00	35.00	4.00						
4.040	GT104.9037.015.17.40.R	4.00	0.15	23	0	1.70	3.70	0.30	17.00	35.00	4.00						
4.045	GT104.9037.025.17.40.R	4.00	0.25	23	0	1.70	3.70	0.30	17.00	35.00	4.00						



		Series no. 25058			25060			25064			
		Cutting direction									
Code no.	Description	D min	R	W1	W2	f	a	t max	La	Lg	D h6
		mm	mm	°	°	mm	mm	mm	mm	mm	mm
4.036	GT104.9037.005.22.40.R	4.00	0.05	23	0	1.70	3.70	0.30	22.00	40.00	4.00
4.041	GT104.9037.015.22.40.R	4.00	0.15	23	0	1.70	3.70	0.30	22.00	40.00	4.00
4.046	GT104.9037.025.22.40.R	4.00	0.25	23	0	1.70	3.70	0.30	22.00	40.00	4.00
4.037	GT104.9037.005.27.40.R	4.00	0.05	23	0	1.70	3.70	0.30	27.00	45.00	4.00
4.042	GT104.9037.015.27.40.R	4.00	0.15	23	0	1.70	3.70	0.30	27.00	45.00	4.00
4.047	GT104.9037.025.27.40.R	4.00	0.25	23	0	1.70	3.70	0.30	27.00	45.00	4.00
4.038	GT104.9037.005.32.40.R	4.00	0.05	23	0	1.70	3.70	0.30	32.00	50.00	4.00
4.043	GT104.9037.015.32.40.R	4.00	0.15	23	0	1.70	3.70	0.30	32.00	50.00	4.00
4.048	GT104.9037.025.32.40.R	4.00	0.25	23	0	1.70	3.70	0.30	32.00	50.00	4.00

		Series no. 25059			25061			25065			
		Cutting direction									
Code no.	Description	D min	R	W1	W2	f	a	t max	La	Lg	D h6
		mm	mm	°	°	mm	mm	mm	mm	mm	mm
4.001	GT104.9006.005.03.07.L	0.70	0.05	23	0	1.95	0.60	0.05	3.00	25.00	4.00
4.002	GT104.9009.005.04.10.L	1.00	0.05	23	0	1.95	0.90	0.10	4.00	25.00	4.00
4.003	GT104.9009.005.07.10.L	1.00	0.05	23	0	1.95	0.90	0.10	7.00	25.00	4.00
4.004	GT104.9014.005.04.15.L	1.50	0.05	23	0	1.95	1.40	0.15	4.00	25.00	4.00
4.007	GT104.9014.010.04.15.L	1.50	0.10	23	0	1.95	1.40	0.15	4.00	25.00	4.00
4.005	GT104.9014.005.07.15.L	1.50	0.05	23	0	1.95	1.40	0.15	7.00	25.00	4.00
4.008	GT104.9014.010.07.15.L	1.50	0.10	23	0	1.95	1.40	0.15	7.00	25.00	4.00
4.006	GT104.9014.005.12.15.L	1.50	0.05	23	0	1.95	1.40	0.15	12.00	30.00	4.00
4.009	GT104.9014.010.12.15.L	1.50	0.10	23	0	1.95	1.40	0.15	12.00	30.00	4.00
4.010	GT104.9019.005.04.20.L	2.00	0.05	23	0	1.95	1.90	0.15	4.00	25.00	4.00
4.014	GT104.9019.010.04.20.L	2.00	0.10	23	0	1.95	1.90	0.15	4.00	25.00	4.00
4.018	GT104.9019.015.04.20.L	2.00	0.15	23	0	1.95	1.90	0.15	4.00	25.00	4.00
4.011	GT104.9019.005.07.20.L	2.00	0.05	23	0	1.95	1.90	0.15	7.00	25.00	4.00
4.015	GT104.9019.010.07.20.L	2.00	0.10	23	0	1.95	1.90	0.15	7.00	25.00	4.00
4.019	GT104.9019.015.07.20.L	2.00	0.15	23	0	1.95	1.90	0.15	7.00	25.00	4.00
4.012	GT104.9019.005.12.20.L	2.00	0.05	23	0	1.95	1.90	0.15	12.00	30.00	4.00
4.016	GT104.9019.010.12.20.L	2.00	0.10	23	0	1.95	1.90	0.15	12.00	30.00	4.00
4.020	GT104.9019.015.12.20.L	2.00	0.15	23	0	1.95	1.90	0.15	12.00	30.00	4.00
4.013	GT104.9019.005.17.20.L	2.00	0.05	23	0	1.95	1.90	0.15	17.00	35.00	4.00
4.017	GT104.9019.010.17.20.L	2.00	0.10	23	0	1.95	1.90	0.15	17.00	35.00	4.00
4.021	GT104.9019.015.17.20.L	2.00	0.15	23	0	1.95	1.90	0.15	17.00	35.00	4.00
4.022	GT104.9026.005.07.30.L	3.00	0.05	23	0	1.95	2.60	0.20	7.00	25.00	4.00
4.026	GT104.9026.010.07.30.L	3.00	0.10	23	0	1.95	2.60	0.20	7.00	25.00	4.00
4.030	GT104.9026.020.07.30.L	3.00	0.20	23	0	1.95	2.60	0.20	7.00	25.00	4.00
4.023	GT104.9026.005.12.30.L	3.00	0.05	23	0	1.95	2.60	0.20	12.00	30.00	4.00
4.027	GT104.9026.010.12.30.L	3.00	0.10	23	0	1.95	2.60	0.20	12.00	30.00	4.00
4.031	GT104.9026.020.12.30.L	3.00	0.20	23	0	1.95	2.60	0.20	12.00	30.00	4.00
4.024	GT104.9026.005.17.30.L	3.00	0.05	23	0	1.95	2.60	0.20	17.00	35.00	4.00
4.028	GT104.9026.010.17.30.L	3.00	0.10	23	0	1.95	2.60	0.20	17.00	35.00	4.00
4.032	GT104.9026.020.17.30.L	3.00	0.20	23	0	1.95	2.60	0.20	17.00	35.00	4.00
4.025	GT104.9026.005.22.30.L	3.00	0.05	23	0	1.95	2.60	0.20	22.00	40.00	4.00
4.029	GT104.9026.010.22.30.L	3.00	0.10	23	0	1.95	2.60	0.20	22.00	40.00	4.00
4.033	GT104.9026.020.22.30.L	3.00	0.20	23	0	1.95	2.60	0.20	22.00	40.00	4.00
4.034	GT104.9037.005.12.40.L	4.00	0.05	23	0	1.70	3.70	0.30	12.00	30.00	4.00
4.039	GT104.9037.015.12.40.L	4.00	0.15	23	0	1.70	3.70	0.30	12.00	30.00	4.00
4.044	GT104.9037.025.12.40.L	4.00	0.25	23	0	1.70	3.70	0.30	12.00	30.00	4.00
4.035	GT104.9037.005.17.40.L	4.00	0.05	23	0	1.70	3.70	0.30	17.00	35.00	4.00
4.040	GT104.9037.015.17.40.L	4.00	0.15	23	0	1.70	3.70	0.30	17.00	35.00	4.00
4.045	GT104.9037.025.17.40.L	4.00	0.25	23	0	1.70	3.70	0.30	17.00	35.00	4.00
4.036	GT104.9037.005.22.40.L	4.00	0.05	23	0	1.70	3.70	0.30	22.00	40.00	4.00
4.041	GT104.9037.015.22.40.L	4.00	0.15	23	0	1.70	3.70	0.30	22.00	40.00	4.00
4.046	GT104.9037.025.22.40.L	4.00	0.25	23	0	1.70	3.70	0.30	22.00	40.00	4.00
4.037	GT104.9037.005.27.40.L	4.00	0.05	23	0	1.70	3.70	0.30	27.00	45.00	4.00
4.042	GT104.9037.015.27.40.L	4.00	0.15	23	0	1.70	3.70	0.30	27.00	45.00	4.00
4.047	GT104.9037.025.27.40.L	4.00	0.25	23	0	1.70	3.70	0.30	27.00	45.00	4.00
4.038	GT104.9037.005.32.40.L	4.00	0.05	23	0	1.70	3.70	0.30	32.00	50.00	4.00
4.043	GT104.9037.015.32.40.L	4.00	0.15	23	0	1.70	3.70	0.30	32.00	50.00	4.00
4.048	GT104.9037.025.32.40.L	4.00	0.25	23	0	1.70	3.70	0.30	32.00	50.00	4.00



Cutting insert for boring out and profiling

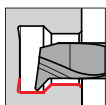

• radial free 47°

for tool holders type GH104/GB104 see from page 16

Cutting data page 148

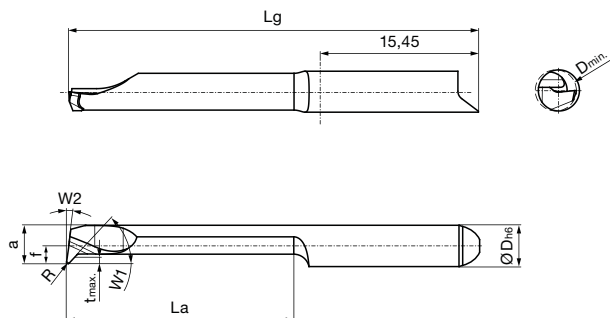

Right hand version shown
Left hand version mirror image

Tool material	Solid carbide		
Type	GT 104	GT 104	GT 104
Surface	S	a	○
	TiN	TiAlN-nanoA	bright



		Series no.			25066			25068			25072		
		Cutting direction											
		Ⓡ			Ⓡ			Ⓡ			Ⓡ		
Code no.	Description	D min	R	W1	W2	f	a	t max	La	Lg	D h6		
		mm	mm	°	°	mm	mm	mm	mm	mm	mm		
4.001	GT104.4717.005.04.20.R	2.00	0.05	47	8	1.95	1.70	0.35	4.00	25.00	4.00		
4.005	GT104.4717.010.04.20.R	2.00	0.10	47	8	1.95	1.70	0.35	4.00	25.00	4.00		
4.009	GT104.4717.015.04.20.R	2.00	0.15	47	8	1.95	1.70	0.35	4.00	25.00	4.00		
4.002	GT104.4717.005.07.20.R	2.00	0.05	47	8	1.95	1.70	0.35	7.00	25.00	4.00		
4.006	GT104.4717.010.07.20.R	2.00	0.10	47	8	1.95	1.70	0.35	7.00	25.00	4.00		
4.010	GT104.4717.015.07.20.R	2.00	0.15	47	8	1.95	1.70	0.35	7.00	25.00	4.00		
4.003	GT104.4717.005.12.20.R	2.00	0.05	47	8	1.95	1.70	0.35	12.00	30.00	4.00		
4.007	GT104.4717.010.12.20.R	2.00	0.10	47	8	1.95	1.70	0.35	12.00	30.00	4.00		
4.011	GT104.4717.015.12.20.R	2.00	0.15	47	8	1.95	1.70	0.35	12.00	30.00	4.00		
4.004	GT104.4717.005.17.20.R	2.00	0.05	47	8	1.95	1.70	0.35	17.00	35.00	4.00		
4.008	GT104.4717.010.17.20.R	2.00	0.10	47	8	1.95	1.70	0.35	17.00	35.00	4.00		
4.012	GT104.4717.015.17.20.R	2.00	0.15	47	8	1.95	1.70	0.35	17.00	35.00	4.00		
4.013	GT104.4727.005.07.30.R	3.00	0.05	47	8	1.95	2.70	0.55	7.00	25.00	4.00		
4.017	GT104.4727.010.07.30.R	3.00	0.10	47	8	1.95	2.70	0.55	7.00	25.00	4.00		
4.021	GT104.4727.025.07.30.R	3.00	0.25	47	8	1.95	2.70	0.55	7.00	25.00	4.00		
4.014	GT104.4727.005.12.30.R	3.00	0.05	47	8	1.95	2.70	0.55	12.00	30.00	4.00		
4.018	GT104.4727.010.12.30.R	3.00	0.10	47	8	1.95	2.70	0.55	12.00	30.00	4.00		
4.022	GT104.4727.025.12.30.R	3.00	0.25	47	8	1.95	2.70	0.55	12.00	30.00	4.00		
4.015	GT104.4727.005.17.30.R	3.00	0.05	47	8	1.95	2.70	0.55	17.00	35.00	4.00		
4.019	GT104.4727.010.17.30.R	3.00	0.10	47	8	1.95	2.70	0.55	17.00	35.00	4.00		
4.023	GT104.4727.025.17.30.R	3.00	0.25	47	8	1.95	2.70	0.55	17.00	35.00	4.00		
4.016	GT104.4727.005.22.30.R	3.00	0.05	47	8	1.95	2.70	0.55	22.00	40.00	4.00		
4.020	GT104.4727.010.22.30.R	3.00	0.10	47	8	1.95	2.70	0.55	22.00	40.00	4.00		
4.024	GT104.4727.025.22.30.R	3.00	0.25	47	8	1.95	2.70	0.55	22.00	40.00	4.00		
4.025	GT104.4737.005.12.40.R	4.00	0.05	47	8	1.70	3.70	0.60	12.00	30.00	4.00		
4.030	GT104.4737.015.12.40.R	4.00	0.15	47	8	1.70	3.70	0.60	12.00	30.00	4.00		
4.035	GT104.4737.025.12.40.R	4.00	0.25	47	8	1.70	3.70	0.60	12.00	30.00	4.00		
4.026	GT104.4737.005.17.40.R	4.00	0.05	47	8	1.70	3.70	0.60	17.00	35.00	4.00		
4.031	GT104.4737.015.17.40.R	4.00	0.15	47	8	1.70	3.70	0.60	17.00	35.00	4.00		
4.036	GT104.4737.025.17.40.R	4.00	0.25	47	8	1.70	3.70	0.60	17.00	35.00	4.00		
4.027	GT104.4737.005.22.40.R	4.00	0.05	47	8	1.70	3.70	0.60	22.00	40.00	4.00		
4.032	GT104.4737.015.22.40.R	4.00	0.15	47	8	1.70	3.70	0.60	22.00	40.00	4.00		
4.037	GT104.4737.025.22.40.R	4.00	0.25	47	8	1.70	3.70	0.60	22.00	40.00	4.00		
4.028	GT104.4737.005.27.40.R	4.00	0.05	47	8	1.70	3.70	0.60	27.00	45.00	4.00		
4.033	GT104.4737.015.27.40.R	4.00	0.15	47	8	1.70	3.70	0.60	27.00	45.00	4.00		
4.038	GT104.4737.025.27.40.R	4.00	0.25	47	8	1.70	3.70	0.60	27.00	45.00	4.00		
4.029	GT104.4737.005.32.40.R	4.00	0.05	47	8	1.70	3.70	0.60	32.00	50.00	4.00		
4.034	GT104.4737.015.32.40.R	4.00	0.15	47	8	1.70	3.70	0.60	32.00	50.00	4.00		
4.039	GT104.4737.025.32.40.R	4.00	0.25	47	8	1.70	3.70	0.60	32.00	50.00	4.00		

Series no. **25067** **25069** **25073**

Cutting direction

System 104

Code no.	Description	D min	R	W1	W2	f	a	t max	La	Lg	D h6
		mm	mm	°	°	mm	mm	mm	mm	mm	mm
4.001	GT104.4717.005.04.20.L	2.00	0.05	47	8	1.95	1.70	0.35	4.00	25.00	4.00
4.005	GT104.4717.010.04.20.L	2.00	0.10	47	8	1.95	1.70	0.35	4.00	25.00	4.00
4.009	GT104.4717.015.04.20.L	2.00	0.15	47	8	1.95	1.70	0.35	4.00	25.00	4.00
4.002	GT104.4717.005.07.20.L	2.00	0.05	47	8	1.95	1.70	0.35	7.00	25.00	4.00
4.006	GT104.4717.010.07.20.L	2.00	0.10	47	8	1.95	1.70	0.35	7.00	25.00	4.00
4.010	GT104.4717.015.07.20.L	2.00	0.15	47	8	1.95	1.70	0.35	7.00	25.00	4.00
4.003	GT104.4717.005.12.20.L	2.00	0.05	47	8	1.95	1.70	0.35	12.00	30.00	4.00
4.007	GT104.4717.010.12.20.L	2.00	0.10	47	8	1.95	1.70	0.35	12.00	30.00	4.00
4.011	GT104.4717.015.12.20.L	2.00	0.15	47	8	1.95	1.70	0.35	12.00	30.00	4.00
4.004	GT104.4717.005.17.20.L	2.00	0.05	47	8	1.95	1.70	0.35	17.00	35.00	4.00
4.008	GT104.4717.010.17.20.L	2.00	0.10	47	8	1.95	1.70	0.35	17.00	35.00	4.00
4.012	GT104.4717.015.17.20.L	2.00	0.15	47	8	1.95	1.70	0.35	17.00	35.00	4.00
4.013	GT104.4727.005.07.30.L	3.00	0.05	47	8	1.95	2.70	0.55	7.00	25.00	4.00
4.017	GT104.4727.010.07.30.L	3.00	0.10	47	8	1.95	2.70	0.55	7.00	25.00	4.00
4.021	GT104.4727.025.07.30.L	3.00	0.25	47	8	1.95	2.70	0.55	7.00	25.00	4.00
4.014	GT104.4727.005.12.30.L	3.00	0.05	47	8	1.95	2.70	0.55	12.00	30.00	4.00
4.018	GT104.4727.010.12.30.L	3.00	0.10	47	8	1.95	2.70	0.55	12.00	30.00	4.00
4.022	GT104.4727.025.12.30.L	3.00	0.25	47	8	1.95	2.70	0.55	12.00	30.00	4.00
4.015	GT104.4727.005.17.30.L	3.00	0.05	47	8	1.95	2.70	0.55	17.00	35.00	4.00
4.019	GT104.4727.010.17.30.L	3.00	0.10	47	8	1.95	2.70	0.55	17.00	35.00	4.00
4.023	GT104.4727.025.17.30.L	3.00	0.25	47	8	1.95	2.70	0.55	17.00	35.00	4.00
4.016	GT104.4727.005.22.30.L	3.00	0.05	47	8	1.95	2.70	0.55	22.00	40.00	4.00
4.020	GT104.4727.010.22.30.L	3.00	0.10	47	8	1.95	2.70	0.55	22.00	40.00	4.00
4.024	GT104.4727.025.22.30.L	3.00	0.25	47	8	1.95	2.70	0.55	22.00	40.00	4.00
4.025	GT104.4737.005.12.40.L	4.00	0.05	47	8	1.70	3.70	0.60	12.00	30.00	4.00
4.030	GT104.4737.015.12.40.L	4.00	0.15	47	8	1.70	3.70	0.60	12.00	30.00	4.00
4.035	GT104.4737.025.12.40.L	4.00	0.25	47	8	1.70	3.70	0.60	12.00	30.00	4.00
4.026	GT104.4737.005.17.40.L	4.00	0.05	47	8	1.70	3.70	0.60	17.00	35.00	4.00
4.031	GT104.4737.015.17.40.L	4.00	0.15	47	8	1.70	3.70	0.60	17.00	35.00	4.00
4.036	GT104.4737.025.17.40.L	4.00	0.25	47	8	1.70	3.70	0.60	17.00	35.00	4.00
4.027	GT104.4737.005.22.40.L	4.00	0.05	47	8	1.70	3.70	0.60	22.00	40.00	4.00
4.032	GT104.4737.015.22.40.L	4.00	0.15	47	8	1.70	3.70	0.60	22.00	40.00	4.00
4.037	GT104.4737.025.22.40.L	4.00	0.25	47	8	1.70	3.70	0.60	22.00	40.00	4.00
4.028	GT104.4737.005.27.40.L	4.00	0.05	47	8	1.70	3.70	0.60	27.00	45.00	4.00
4.033	GT104.4737.015.27.40.L	4.00	0.15	47	8	1.70	3.70	0.60	27.00	45.00	4.00
4.038	GT104.4737.025.27.40.L	4.00	0.25	47	8	1.70	3.70	0.60	27.00	45.00	4.00
4.029	GT104.4737.005.32.40.L	4.00	0.05	47	8	1.70	3.70	0.60	32.00	50.00	4.00
4.034	GT104.4737.015.32.40.L	4.00	0.15	47	8	1.70	3.70	0.60	32.00	50.00	4.00
4.039	GT104.4737.025.32.40.L	4.00	0.25	47	8	1.70	3.70	0.60	32.00	50.00	4.00



Cutting insert for boring out and profiling

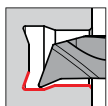

• face free 20°

for tool holders type GH104/GB104 see from page 16

Tool material	Solid carbide		
Type	GT 104	GT 104	GT 104
Surface	S	a	○
	TiN	TiAlN-nanoA	bright

Cutting data page 148

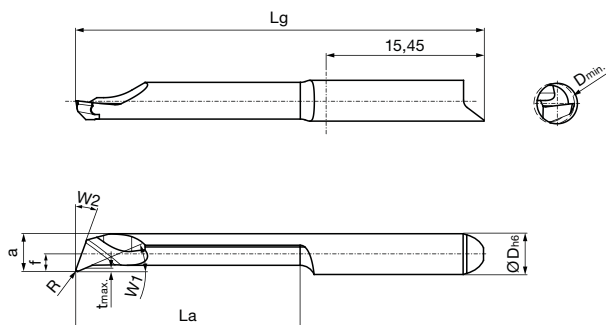

Right hand version shown
Left hand version mirror image



Series no.	25074	25076	25080
Cutting direction	(R)	(R)	(R)

Code no.	Description	D min	R	W1	W2	f	a	t max	La	Lg	D h6
		mm	mm	°	°	mm	mm	mm	mm	mm	mm
4.001	GT104.2026.005.07.30.R	3.00	0.05	23	20	1.95	2.60	0.20	7.00	25.00	4.00
4.005	GT104.2026.010.07.30.R	3.00	0.10	23	20	1.95	2.60	0.20	7.00	25.00	4.00
4.009	GT104.2026.020.07.30.R	3.00	0.20	23	20	1.95	2.60	0.20	7.00	25.00	4.00
4.002	GT104.2026.005.12.30.R	3.00	0.05	23	20	1.95	2.60	0.20	12.00	30.00	4.00
4.006	GT104.2026.010.12.30.R	3.00	0.10	23	20	1.95	2.60	0.20	12.00	30.00	4.00
4.010	GT104.2026.020.12.30.R	3.00	0.20	23	20	1.95	2.60	0.20	12.00	30.00	4.00
4.003	GT104.2026.005.17.30.R	3.00	0.05	23	20	1.95	2.60	0.20	17.00	35.00	4.00
4.007	GT104.2026.010.17.30.R	3.00	0.10	23	20	1.95	2.60	0.20	17.00	35.00	4.00
4.011	GT104.2026.020.17.30.R	3.00	0.20	23	20	1.95	2.60	0.20	17.00	35.00	4.00
4.004	GT104.2026.005.22.30.R	3.00	0.05	23	20	1.95	2.60	0.20	22.00	40.00	4.00
4.008	GT104.2026.010.22.30.R	3.00	0.10	23	20	1.95	2.60	0.20	22.00	40.00	4.00
4.012	GT104.2026.020.22.30.R	3.00	0.20	23	20	1.95	2.60	0.20	22.00	40.00	4.00
4.013	GT104.2037.005.12.40.R	4.00	0.05	23	20	1.70	3.70	0.30	12.00	30.00	4.00
4.018	GT104.2037.015.12.40.R	4.00	0.15	23	20	1.70	3.70	0.30	12.00	30.00	4.00
4.023	GT104.2037.025.12.40.R	4.00	0.25	23	20	1.70	3.70	0.30	12.00	30.00	4.00
4.014	GT104.2037.005.17.40.R	4.00	0.05	23	20	1.70	3.70	0.30	17.00	35.00	4.00
4.019	GT104.2037.015.17.40.R	4.00	0.15	23	20	1.70	3.70	0.30	17.00	35.00	4.00
4.024	GT104.2037.025.17.40.R	4.00	0.25	23	20	1.70	3.70	0.30	17.00	35.00	4.00
4.015	GT104.2037.005.22.40.R	4.00	0.05	23	20	1.70	3.70	0.30	22.00	40.00	4.00
4.020	GT104.2037.015.22.40.R	4.00	0.15	23	20	1.70	3.70	0.30	22.00	40.00	4.00
4.025	GT104.2037.025.22.40.R	4.00	0.25	23	20	1.70	3.70	0.30	22.00	40.00	4.00
4.016	GT104.2037.005.27.40.R	4.00	0.05	23	20	1.70	3.70	0.30	27.00	45.00	4.00
4.021	GT104.2037.015.27.40.R	4.00	0.15	23	20	1.70	3.70	0.30	27.00	45.00	4.00
4.026	GT104.2037.025.27.40.R	4.00	0.25	23	20	1.70	3.70	0.30	27.00	45.00	4.00
4.017	GT104.2037.005.32.40.R	4.00	0.05	23	20	1.70	3.70	0.30	32.00	50.00	4.00
4.022	GT104.2037.015.32.40.R	4.00	0.15	23	20	1.70	3.70	0.30	32.00	50.00	4.00
4.027	GT104.2037.025.32.40.R	4.00	0.25	23	20	1.70	3.70	0.30	32.00	50.00	4.00

Series no. **25075** **25077** **25081**Cutting direction   

Code no.	Description	D min	R	W1	W2	f	a	t max	La	Lg	D h6
		mm	mm	°	°	mm	mm	mm	mm	mm	mm
4.001	GT104.2026.005.07.30.L	3.00	0.05	23	20	1.95	2.60	0.20	7.00	25.00	4.00
4.005	GT104.2026.010.07.30.L	3.00	0.10	23	20	1.95	2.60	0.20	7.00	25.00	4.00
4.009	GT104.2026.020.07.30.L	3.00	0.20	23	20	1.95	2.60	0.20	7.00	25.00	4.00
4.002	GT104.2026.005.12.30.L	3.00	0.05	23	20	1.95	2.60	0.20	12.00	30.00	4.00
4.006	GT104.2026.010.12.30.L	3.00	0.10	23	20	1.95	2.60	0.20	12.00	30.00	4.00
4.010	GT104.2026.020.12.30.L	3.00	0.20	23	20	1.95	2.60	0.20	12.00	30.00	4.00
4.003	GT104.2026.005.17.30.L	3.00	0.05	23	20	1.95	2.60	0.20	17.00	35.00	4.00
4.007	GT104.2026.010.17.30.L	3.00	0.10	23	20	1.95	2.60	0.20	17.00	35.00	4.00
4.011	GT104.2026.020.17.30.L	3.00	0.20	23	20	1.95	2.60	0.20	17.00	35.00	4.00
4.004	GT104.2026.005.22.30.L	3.00	0.05	23	20	1.95	2.60	0.20	22.00	40.00	4.00
4.008	GT104.2026.010.22.30.L	3.00	0.10	23	20	1.95	2.60	0.20	22.00	40.00	4.00
4.012	GT104.2026.020.22.30.L	3.00	0.20	23	20	1.95	2.60	0.20	22.00	40.00	4.00
4.013	GT104.2037.005.12.40.L	4.00	0.05	23	20	1.70	3.70	0.30	12.00	30.00	4.00
4.018	GT104.2037.015.12.40.L	4.00	0.15	23	20	1.70	3.70	0.30	12.00	30.00	4.00
4.023	GT104.2037.025.12.40.L	4.00	0.25	23	20	1.70	3.70	0.30	12.00	30.00	4.00
4.014	GT104.2037.005.17.40.L	4.00	0.05	23	20	1.70	3.70	0.30	17.00	35.00	4.00
4.019	GT104.2037.015.17.40.L	4.00	0.15	23	20	1.70	3.70	0.30	17.00	35.00	4.00
4.024	GT104.2037.025.17.40.L	4.00	0.25	23	20	1.70	3.70	0.30	17.00	35.00	4.00
4.015	GT104.2037.005.22.40.L	4.00	0.05	23	20	1.70	3.70	0.30	22.00	40.00	4.00
4.020	GT104.2037.015.22.40.L	4.00	0.15	23	20	1.70	3.70	0.30	22.00	40.00	4.00
4.025	GT104.2037.025.22.40.L	4.00	0.25	23	20	1.70	3.70	0.30	22.00	40.00	4.00
4.016	GT104.2037.005.27.40.L	4.00	0.05	23	20	1.70	3.70	0.30	27.00	45.00	4.00
4.021	GT104.2037.015.27.40.L	4.00	0.15	23	20	1.70	3.70	0.30	27.00	45.00	4.00
4.026	GT104.2037.025.27.40.L	4.00	0.25	23	20	1.70	3.70	0.30	27.00	45.00	4.00
4.017	GT104.2037.005.32.40.L	4.00	0.05	23	20	1.70	3.70	0.30	32.00	50.00	4.00
4.022	GT104.2037.015.32.40.L	4.00	0.15	23	20	1.70	3.70	0.30	32.00	50.00	4.00
4.027	GT104.2037.025.32.40.L	4.00	0.25	23	20	1.70	3.70	0.30	32.00	50.00	4.00



Cutting insert for boring out and profiling

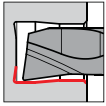

• radial free 8°

for tool holders type GH104/GB104 see from page 16

Tool material	Solid carbide			
	Type	GT 104	GT 104	GT 104
Surface	S	a	○	
	TiN	TiAlN-nanoA	bright	

Cutting data page 148

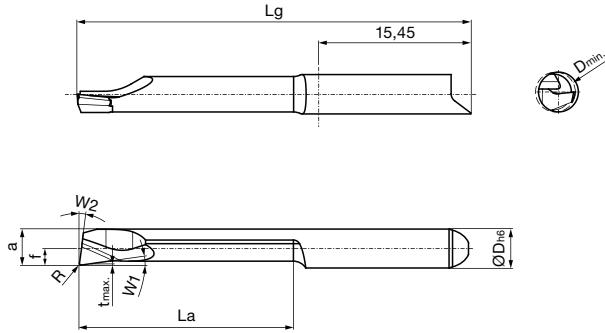

Right hand version shown
Left hand version mirror image



Series no.	25082	25084	25088
Cutting direction	(R)	(R)	(R)

Code no.	Description	D min	R	W1	W2	f	a	t max	La	Lg	D h6
		mm	mm	°	°	mm	mm	mm	mm	mm	mm
4.001	GT104.0827.005.07.30.R	3.00	0.05	8	8	1.95	2.70	0.15	7.00	25.00	4.00
4.005	GT104.0827.010.07.30.R	3.00	0.10	8	8	1.95	2.70	0.15	7.00	25.00	4.00
4.009	GT104.0827.020.07.30.R	3.00	0.20	8	8	1.95	2.70	0.15	7.00	25.00	4.00
4.002	GT104.0827.005.12.30.R	3.00	0.05	8	8	1.95	2.70	0.15	12.00	30.00	4.00
4.006	GT104.0827.010.12.30.R	3.00	0.10	8	8	1.95	2.70	0.15	12.00	30.00	4.00
4.010	GT104.0827.020.12.30.R	3.00	0.20	8	8	1.95	2.70	0.15	12.00	30.00	4.00
4.003	GT104.0827.005.17.30.R	3.00	0.05	8	8	1.95	2.70	0.15	17.00	35.00	4.00
4.007	GT104.0827.010.17.30.R	3.00	0.10	8	8	1.95	2.70	0.15	17.00	35.00	4.00
4.011	GT104.0827.020.17.30.R	3.00	0.20	8	8	1.95	2.70	0.15	17.00	35.00	4.00
4.004	GT104.0827.005.22.30.R	3.00	0.05	8	8	1.95	2.70	0.15	22.00	40.00	4.00
4.008	GT104.0827.010.22.30.R	3.00	0.10	8	8	1.95	2.70	0.15	22.00	40.00	4.00
4.012	GT104.0827.020.22.30.R	3.00	0.20	8	8	1.95	2.70	0.15	22.00	40.00	4.00
4.013	GT104.0837.005.12.40.R	4.00	0.05	8	8	1.70	3.70	0.15	12.00	30.00	4.00
4.018	GT104.0837.015.12.40.R	4.00	0.15	8	8	1.70	3.70	0.15	12.00	30.00	4.00
4.023	GT104.0837.025.12.40.R	4.00	0.25	8	8	1.70	3.70	0.15	12.00	30.00	4.00
4.014	GT104.0837.005.17.40.R	4.00	0.05	8	8	1.70	3.70	0.15	17.00	35.00	4.00
4.019	GT104.0837.015.17.40.R	4.00	0.15	8	8	1.70	3.70	0.15	17.00	35.00	4.00
4.024	GT104.0837.025.17.40.R	4.00	0.25	8	8	1.70	3.70	0.15	17.00	35.00	4.00
4.015	GT104.0837.005.22.40.R	4.00	0.05	8	8	1.70	3.70	0.15	22.00	40.00	4.00
4.020	GT104.0837.015.22.40.R	4.00	0.15	8	8	1.70	3.70	0.15	22.00	40.00	4.00
4.025	GT104.0837.025.22.40.R	4.00	0.25	8	8	1.70	3.70	0.15	22.00	40.00	4.00
4.016	GT104.0837.005.27.40.R	4.00	0.05	8	8	1.70	3.70	0.15	27.00	45.00	4.00
4.021	GT104.0837.015.27.40.R	4.00	0.15	8	8	1.70	3.70	0.15	27.00	45.00	4.00
4.026	GT104.0837.025.27.40.R	4.00	0.25	8	8	1.70	3.70	0.15	27.00	45.00	4.00
4.017	GT104.0837.005.32.40.R	4.00	0.05	8	8	1.70	3.70	0.15	32.00	50.00	4.00
4.022	GT104.0837.015.32.40.R	4.00	0.15	8	8	1.70	3.70	0.15	32.00	50.00	4.00
4.027	GT104.0837.025.32.40.R	4.00	0.25	8	8	1.70	3.70	0.15	32.00	50.00	4.00

Series no. **25083** **25085** **25089**Cutting direction   

Code no.	Description	D min	R	W1	W2	f	a	t max	La	Lg	D h6
		mm	mm	°	°	mm	mm	mm	mm	mm	mm
4.001	GT104.0827.005.07.30.L	3.00	0.05	8	8	1.95	2.70	0.15	7.00	25.00	4.00
4.005	GT104.0827.010.07.30.L	3.00	0.10	8	8	1.95	2.70	0.15	7.00	25.00	4.00
4.009	GT104.0827.020.07.30.L	3.00	0.20	8	8	1.95	2.70	0.15	7.00	25.00	4.00
4.002	GT104.0827.005.12.30.L	3.00	0.05	8	8	1.95	2.70	0.15	12.00	30.00	4.00
4.006	GT104.0827.010.12.30.L	3.00	0.10	8	8	1.95	2.70	0.15	12.00	30.00	4.00
4.010	GT104.0827.020.12.30.L	3.00	0.20	8	8	1.95	2.70	0.15	12.00	30.00	4.00
4.003	GT104.0827.005.17.30.L	3.00	0.05	8	8	1.95	2.70	0.15	17.00	35.00	4.00
4.007	GT104.0827.010.17.30.L	3.00	0.10	8	8	1.95	2.70	0.15	17.00	35.00	4.00
4.011	GT104.0827.020.17.30.L	3.00	0.20	8	8	1.95	2.70	0.15	17.00	35.00	4.00
4.004	GT104.0827.005.22.30.L	3.00	0.05	8	8	1.95	2.70	0.15	22.00	40.00	4.00
4.008	GT104.0827.010.22.30.L	3.00	0.10	8	8	1.95	2.70	0.15	22.00	40.00	4.00
4.012	GT104.0827.020.22.30.L	3.00	0.20	8	8	1.95	2.70	0.15	22.00	40.00	4.00
4.013	GT104.0837.005.12.40.L	4.00	0.05	8	8	1.70	3.70	0.15	12.00	30.00	4.00
4.018	GT104.0837.015.12.40.L	4.00	0.15	8	8	1.70	3.70	0.15	12.00	30.00	4.00
4.023	GT104.0837.025.12.40.L	4.00	0.25	8	8	1.70	3.70	0.15	12.00	30.00	4.00
4.014	GT104.0837.005.17.40.L	4.00	0.05	8	8	1.70	3.70	0.15	17.00	35.00	4.00
4.019	GT104.0837.015.17.40.L	4.00	0.15	8	8	1.70	3.70	0.15	17.00	35.00	4.00
4.024	GT104.0837.025.17.40.L	4.00	0.25	8	8	1.70	3.70	0.15	17.00	35.00	4.00
4.015	GT104.0837.005.22.40.L	4.00	0.05	8	8	1.70	3.70	0.15	22.00	40.00	4.00
4.020	GT104.0837.015.22.40.L	4.00	0.15	8	8	1.70	3.70	0.15	22.00	40.00	4.00
4.025	GT104.0837.025.22.40.L	4.00	0.25	8	8	1.70	3.70	0.15	22.00	40.00	4.00
4.016	GT104.0837.005.27.40.L	4.00	0.05	8	8	1.70	3.70	0.15	27.00	45.00	4.00
4.021	GT104.0837.015.27.40.L	4.00	0.15	8	8	1.70	3.70	0.15	27.00	45.00	4.00
4.026	GT104.0837.025.27.40.L	4.00	0.25	8	8	1.70	3.70	0.15	27.00	45.00	4.00
4.017	GT104.0837.005.32.40.L	4.00	0.05	8	8	1.70	3.70	0.15	32.00	50.00	4.00
4.022	GT104.0837.015.32.40.L	4.00	0.15	8	8	1.70	3.70	0.15	32.00	50.00	4.00
4.027	GT104.0837.025.32.40.L	4.00	0.25	8	8	1.70	3.70	0.15	32.00	50.00	4.00



Cutting insert for boring out and profiling

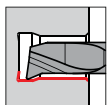

• WIPER-geometry

for tool holders type GH104/GB104 see from page 16

Tool material	Solid carbide			
	Type	GJ 104	GJ 104	GJ 104
Surface	S	a	○	
	TiN	TiAlN-nanoA	bright	

Cutting data page 148

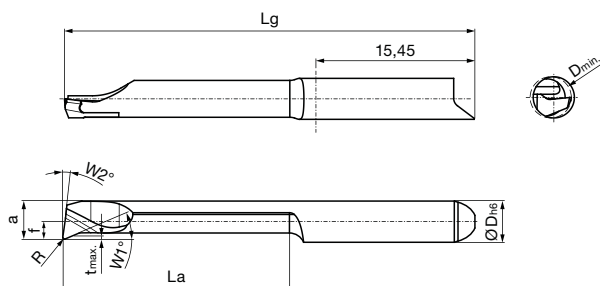

Right hand version shown
Left hand version mirror image

Series no.	25090	25092	25096
Cutting direction	(R)	(R)	(R)

Code no.	Description	D min	R	W1	W2	f	a	t max	La	Lg	D h6
		mm	mm	°	°	mm	mm	mm	mm	mm	mm
4.001	GJ104.2319.010.04.20.R	2.00	0.10	23	8	1.95	1.90	0.15	4.00	25.00	4.00
4.002	GJ104.2319.010.07.20.R	2.00	0.10	23	8	1.95	1.90	0.15	7.00	25.00	4.00
4.003	GJ104.2319.010.12.20.R	2.00	0.10	23	8	1.95	1.90	0.15	12.00	30.00	4.00
4.004	GJ104.2319.010.17.20.R	2.00	0.10	23	8	1.95	1.90	0.15	17.00	35.00	4.00
4.005	GJ104.2326.015.07.30.R	3.00	0.15	23	8	1.95	2.60	0.20	7.00	25.00	4.00
4.006	GJ104.2326.015.12.30.R	3.00	0.15	23	8	1.95	2.60	0.20	12.00	30.00	4.00
4.007	GJ104.2326.015.17.30.R	3.00	0.15	23	8	1.95	2.60	0.20	17.00	35.00	4.00
4.008	GJ104.2326.015.22.30.R	3.00	0.15	23	8	1.95	2.60	0.20	22.00	40.00	4.00
4.009	GJ104.2337.020.12.40.R	4.00	0.20	23	8	1.70	3.70	0.30	12.00	30.00	4.00
4.010	GJ104.2337.020.17.40.R	4.00	0.20	23	8	1.70	3.70	0.30	17.00	35.00	4.00
4.011	GJ104.2337.020.22.40.R	4.00	0.20	23	8	1.70	3.70	0.30	22.00	40.00	4.00
4.012	GJ104.2337.020.27.40.R	4.00	0.20	23	8	1.70	3.70	0.30	27.00	45.00	4.00
4.013	GJ104.2337.020.32.40.R	4.00	0.20	23	8	1.70	3.70	0.30	32.00	50.00	4.00

Series no.	25091	25093	25097
Cutting direction	(L)	(L)	(L)

Code no.	Description	D min	R	W1	W2	f	a	t max	La	Lg	D h6
		mm	mm	°	°	mm	mm	mm	mm	mm	mm
4.001	GJ104.2319.010.04.20.L	2.00	0.10	23	8	1.95	1.90	0.15	4.00	25.00	4.00
4.002	GJ104.2319.010.07.20.L	2.00	0.10	23	8	1.95	1.90	0.15	7.00	25.00	4.00
4.003	GJ104.2319.010.12.20.L	2.00	0.10	23	8	1.95	1.90	0.15	12.00	30.00	4.00
4.004	GJ104.2319.010.17.20.L	2.00	0.10	23	8	1.95	1.90	0.15	17.00	35.00	4.00
4.005	GJ104.2326.015.07.30.L	3.00	0.15	23	8	1.95	2.60	0.20	7.00	25.00	4.00
4.006	GJ104.2326.015.12.30.L	3.00	0.15	23	8	1.95	2.60	0.20	12.00	30.00	4.00
4.007	GJ104.2326.015.17.30.L	3.00	0.15	23	8	1.95	2.60	0.20	17.00	35.00	4.00
4.008	GJ104.2326.015.22.30.L	3.00	0.15	23	8	1.95	2.60	0.20	22.00	40.00	4.00
4.009	GJ104.2337.020.12.40.L	4.00	0.20	23	8	1.70	3.70	0.30	12.00	30.00	4.00
4.010	GJ104.2337.020.17.40.L	4.00	0.20	23	8	1.70	3.70	0.30	17.00	35.00	4.00
4.011	GJ104.2337.020.22.40.L	4.00	0.20	23	8	1.70	3.70	0.30	22.00	40.00	4.00
4.012	GJ104.2337.020.27.40.L	4.00	0.20	23	8	1.70	3.70	0.30	27.00	45.00	4.00
4.013	GJ104.2337.020.32.40.L	4.00	0.20	23	8	1.70	3.70	0.30	32.00	50.00	4.00



Cutting insert for back boring and profiling

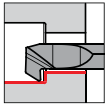

• radial free 32°

for tool holders type GH104/GB104 see from page 16

Tool material	Solid carbide		
Type	GT 104	GT 104	GT 104
Surface	S TiN	a TiAlN-nanoA	○ bright

Cutting data page 148

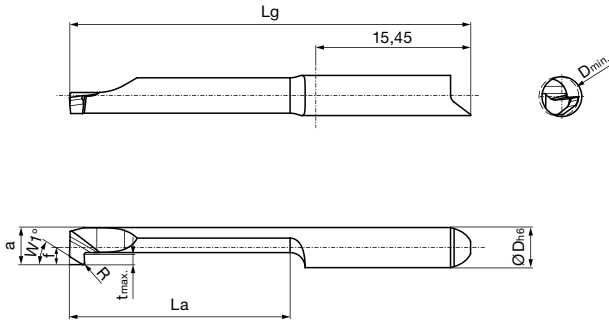

Right hand version shown
Left hand version mirror image



Series no. **25106** **25108** **25112**

Cutting direction **R** **R** **R**

Code no.	Description	D min	R	W1	f	a	t max	La	Lg	D h6
		mm	mm	°	mm	mm	mm	mm	mm	mm
4.001	GT104.3217.010.04.20.R	2.00	0.10	32	1.95	1.70	0.30	4.00	25.00	4.00
4.002	GT104.3217.010.07.20.R	2.00	0.10	32	1.95	1.70	0.30	7.00	25.00	4.00
4.003	GT104.3217.010.12.20.R	2.00	0.10	32	1.95	1.70	0.30	12.00	30.00	4.00
4.004	GT104.3217.010.17.20.R	2.00	0.10	32	1.95	1.70	0.70	17.00	35.00	4.00
4.005	GT104.3226.005.07.30.R	3.00	0.05	32	1.95	2.60	0.70	7.00	25.00	4.00
4.009	GT104.3226.010.07.30.R	3.00	0.10	32	1.95	2.60	0.70	7.00	25.00	4.00
4.006	GT104.3226.005.12.30.R	3.00	0.05	32	1.95	2.60	0.70	12.00	30.00	4.00
4.010	GT104.3226.010.12.30.R	3.00	0.10	32	1.95	2.60	0.70	12.00	30.00	4.00
4.007	GT104.3226.005.17.30.R	3.00	0.05	32	1.95	2.60	0.70	17.00	35.00	4.00
4.011	GT104.3226.010.17.30.R	3.00	0.10	32	1.95	2.60	0.70	17.00	35.00	4.00
4.008	GT104.3226.005.22.30.R	3.00	0.05	32	1.95	2.60	0.70	22.00	40.00	4.00
4.012	GT104.3226.010.22.30.R	3.00	0.10	32	1.95	2.60	0.70	22.00	40.00	4.00
4.013	GT104.3237.010.12.40.R	4.00	0.10	32	1.7	3.70	1.00	12.00	30.00	4.00
4.018	GT104.3237.015.12.40.R	4.00	0.15	32	1.7	3.70	1.00	12.00	30.00	4.00
4.014	GT104.3237.010.17.40.R	4.00	0.10	32	1.7	3.70	1.00	17.00	35.00	4.00
4.019	GT104.3237.015.17.40.R	4.00	0.15	32	1.7	3.70	1.00	17.00	35.00	4.00
4.015	GT104.3237.010.22.40.R	4.00	0.10	32	1.7	3.70	1.00	22.00	40.00	4.00
4.020	GT104.3237.015.22.40.R	4.00	0.15	32	1.7	3.70	1.00	22.00	40.00	4.00
4.016	GT104.3237.010.27.40.R	4.00	0.10	32	1.7	3.70	1.00	27.00	45.00	4.00
4.021	GT104.3237.015.27.40.R	4.00	0.15	32	1.7	3.70	1.00	27.00	45.00	4.00
4.017	GT104.3237.010.32.40.R	4.00	0.10	32	1.7	3.70	1.00	32.00	50.00	4.00
4.022	GT104.3237.015.32.40.R	4.00	0.15	32	1.7	3.70	1.00	32.00	50.00	4.00

Series no. **25107** **25109** **25113**Cutting direction   

Code no.	Description	D min	R	W1	f	a	t max	La	Lg	D h6
		mm	mm	°	mm	mm	mm	mm	mm	mm
4.001	GT104.3217.010.04.20.L	2.00	0.10	32	1.95	1.70	0.30	4.00	25.00	4.00
4.002	GT104.3217.010.07.20.L	2.00	0.10	32	1.95	1.70	0.30	7.00	25.00	4.00
4.003	GT104.3217.010.12.20.L	2.00	0.10	32	1.95	1.70	0.30	12.00	30.00	4.00
4.004	GT104.3217.010.17.20.L	2.00	0.10	32	1.95	1.70	0.70	17.00	35.00	4.00
4.005	GT104.3226.005.07.30.L	3.00	0.05	32	1.95	2.60	0.70	7.00	25.00	4.00
4.009	GT104.3226.010.07.30.L	3.00	0.10	32	1.95	2.60	0.70	7.00	25.00	4.00
4.006	GT104.3226.005.12.30.L	3.00	0.05	32	1.95	2.60	0.70	12.00	30.00	4.00
4.010	GT104.3226.010.12.30.L	3.00	0.10	32	1.95	2.60	0.70	12.00	30.00	4.00
4.007	GT104.3226.005.17.30.L	3.00	0.05	32	1.95	2.60	0.70	17.00	35.00	4.00
4.011	GT104.3226.010.17.30.L	3.00	0.10	32	1.95	2.60	0.70	17.00	35.00	4.00
4.008	GT104.3226.005.22.30.L	3.00	0.05	32	1.95	2.60	0.70	22.00	40.00	4.00
4.012	GT104.3226.010.22.30.L	3.00	0.10	32	1.95	2.60	0.70	22.00	40.00	4.00
4.013	GT104.3237.010.12.40.L	4.00	0.10	32	1.7	3.70	1.00	12.00	30.00	4.00
4.018	GT104.3237.015.12.40.L	4.00	0.15	32	1.7	3.70	1.00	12.00	30.00	4.00
4.014	GT104.3237.010.17.40.L	4.00	0.10	32	1.7	3.70	1.00	17.00	35.00	4.00
4.019	GT104.3237.015.17.40.L	4.00	0.15	32	1.7	3.70	1.00	17.00	35.00	4.00
4.015	GT104.3237.010.22.40.L	4.00	0.10	32	1.7	3.70	1.00	22.00	40.00	4.00
4.020	GT104.3237.015.22.40.L	4.00	0.15	32	1.7	3.70	1.00	22.00	40.00	4.00
4.016	GT104.3237.010.27.40.L	4.00	0.10	32	1.7	3.70	1.00	27.00	45.00	4.00
4.021	GT104.3237.015.27.40.L	4.00	0.15	32	1.7	3.70	1.00	27.00	45.00	4.00
4.017	GT104.3237.010.32.40.L	4.00	0.10	32	1.7	3.70	1.00	32.00	50.00	4.00
4.022	GT104.3237.015.32.40.L	4.00	0.15	32	1.7	3.70	1.00	32.00	50.00	4.00



Cutting insert for boring out and chamfering

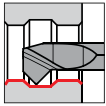

• 45° both sides

for tool holders type GH104/GB104 see from page 16

Cutting data page 148

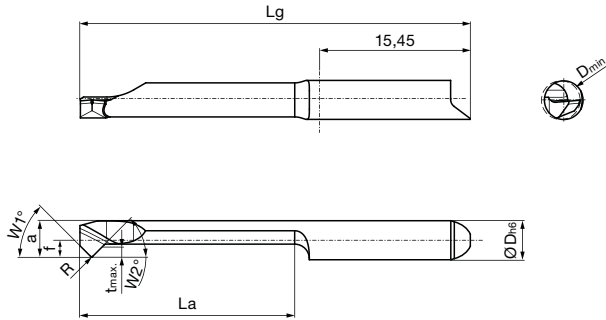

Right hand version shown
Left hand version mirror image



Series no. **25114** **25116** **25120**

Cutting direction

Code no.	Description	D min	R	W1	W2	f	a	t max	La	Lg	D h6
		mm	mm	°	°	mm	mm	mm	mm	mm	mm
4.001	GT104.4518.010.04.20.R	2.00	0.10	45	45	1.95	1.80	0.50	4.00	25.00	4.00
4.002	GT104.4518.010.07.20.R	2.00	0.10	45	45	1.95	1.80	0.50	7.00	25.00	4.00
4.003	GT104.4518.010.12.20.R	2.00	0.10	45	45	1.95	1.80	0.50	12.00	30.00	4.00
4.004	GT104.4518.010.17.20.R	2.00	0.10	45	45	1.95	1.80	0.50	17.00	35.00	4.00
4.005	GT104.4527.010.07.30.R	3.00	0.10	45	45	1.95	2.70	0.70	7.00	25.00	4.00
4.006	GT104.4527.010.12.30.R	3.00	0.10	45	45	1.95	2.70	0.70	12.00	30.00	4.00
4.007	GT104.4527.010.17.30.R	3.00	0.10	45	45	1.95	2.70	0.70	17.00	35.00	4.00
4.008	GT104.4527.010.22.30.R	3.00	0.10	45	45	1.95	2.70	0.70	22.00	40.00	4.00
4.009	GT104.4537.015.12.40.R	4.00	0.15	45	45	1.70	3.70	1.00	12.00	30.00	4.00
4.010	GT104.4537.015.17.40.R	4.00	0.15	45	45	1.70	3.70	1.00	17.00	35.00	4.00
4.011	GT104.4537.015.22.40.R	4.00	0.15	45	45	1.70	3.70	1.00	22.00	40.00	4.00
4.012	GT104.4537.015.27.40.R	4.00	0.15	45	45	1.70	3.70	1.00	27.00	45.00	4.00
4.013	GT104.4537.015.32.40.R	4.00	0.15	45	45	1.70	3.70	1.00	32.00	50.00	4.00

Series no. **25115** **25117** **25121**

Cutting direction

Code no.	Description	D min	R	W1	W2	f	a	t max	La	Lg	D h6
		mm	mm	°	°	mm	mm	mm	mm	mm	mm
4.001	GT104.4518.010.04.20.L	2.00	0.10	45	45	1.95	1.80	0.50	4.00	25.00	4.00
4.002	GT104.4518.010.07.20.L	2.00	0.10	45	45	1.95	1.80	0.50	7.00	25.00	4.00
4.003	GT104.4518.010.12.20.L	2.00	0.10	45	45	1.95	1.80	0.50	12.00	30.00	4.00
4.004	GT104.4518.010.17.20.L	2.00	0.10	45	45	1.95	1.80	0.50	17.00	35.00	4.00
4.005	GT104.4527.010.07.30.L	3.00	0.10	45	45	1.95	2.70	0.70	7.00	25.00	4.00
4.006	GT104.4527.010.12.30.L	3.00	0.10	45	45	1.95	2.70	0.70	12.00	30.00	4.00
4.007	GT104.4527.010.17.30.L	3.00	0.10	45	45	1.95	2.70	0.70	17.00	35.00	4.00
4.008	GT104.4527.010.22.30.L	3.00	0.10	45	45	1.95	2.70	0.70	22.00	40.00	4.00
4.009	GT104.4537.015.12.40.L	4.00	0.15	45	45	1.70	3.70	1.00	12.00	30.00	4.00
4.010	GT104.4537.015.17.40.L	4.00	0.15	45	45	1.70	3.70	1.00	17.00	35.00	4.00
4.011	GT104.4537.015.22.40.L	4.00	0.15	45	45	1.70	3.70	1.00	22.00	40.00	4.00
4.012	GT104.4537.015.27.40.L	4.00	0.15	45	45	1.70	3.70	1.00	27.00	45.00	4.00
4.013	GT104.4537.015.32.40.L	4.00	0.15	45	45	1.70	3.70	1.00	32.00	50.00	4.00



Cutting insert for internal grooving, straight slots

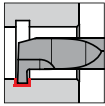

- grooving depth up to 1 mm

for tool holders type GH104/GB104 see from page 16

Tool material	Solid carbide		
Type	GE 104	GE 104	GE 104
Surface	S	a	○
	TiN	TiAlN-nanoA	bright

Cutting data page 148

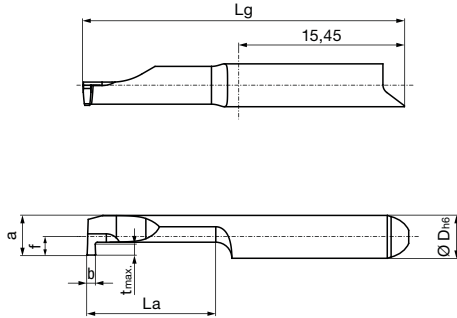

Right hand version shown
Left hand version mirror image

Series no.	25124	25126	25130
Cutting direction	R	R	R

Code no.	Description	D min	b	f	a	t max	La	Lg	D h6
		mm	mm	mm	mm	mm	mm	mm	mm
4.001	GE104.0030.000.04.10.R	1.00	0.30	1.95	0.85	0.20	4.00	25.00	4.00
4.002	GE104.0030.000.07.10.R	1.00	0.30	1.95	0.85	0.20	7.00	25.00	4.00
4.003	GE104.0040.000.04.15.R	1.50	0.40	1.95	1.30	0.40	4.00	25.00	4.00
4.004	GE104.0040.000.07.15.R	1.50	0.40	1.95	1.30	0.40	7.00	25.00	4.00
4.005	GE104.0040.000.12.15.R	1.50	0.40	1.95	1.30	0.40	12.00	30.00	4.00
4.006	GE104.0050.000.04.20.R	2.00	0.50	1.95	1.80	0.50	4.00	25.00	4.00
4.007	GE104.0050.000.07.20.R	2.00	0.50	1.95	1.80	0.50	7.00	25.00	4.00
4.008	GE104.0050.000.12.20.R	2.00	0.50	1.95	1.80	0.50	12.00	30.00	4.00
4.009	GE104.0050.000.17.20.R	2.00	0.50	1.95	1.80	0.50	17.00	35.00	4.00
4.010	GE104.0070.000.07.30.R	3.00	0.70	1.95	2.70	0.70	7.00	25.00	4.00
4.011	GE104.0070.000.12.30.R	3.00	0.70	1.95	2.70	0.70	12.00	30.00	4.00
4.012	GE104.0070.000.17.30.R	3.00	0.70	1.95	2.70	0.70	17.00	35.00	4.00
4.013	GE104.0070.000.22.30.R	3.00	0.70	1.95	2.70	0.70	22.00	40.00	4.00
4.014	GE104.0079.000.12.40.R	4.00	0.79	1.70	3.70	1.00	12.00	30.00	4.00
4.015	GE104.0079.000.17.40.R	4.00	0.79	1.70	3.70	1.00	17.00	35.00	4.00
4.016	GE104.0079.000.22.40.R	4.00	0.79	1.70	3.70	1.00	22.00	40.00	4.00
4.017	GE104.0079.000.27.40.R	4.00	0.79	1.70	3.70	1.00	27.00	45.00	4.00
4.018	GE104.0079.000.32.40.R	4.00	0.79	1.70	3.70	1.00	32.00	50.00	4.00
4.019	GE104.0100.000.12.40.R	4.00	1.00	1.70	3.70	1.00	12.00	30.00	4.00
4.020	GE104.0100.000.17.40.R	4.00	1.00	1.70	3.70	1.00	17.00	35.00	4.00
4.021	GE104.0100.000.22.40.R	4.00	1.00	1.70	3.70	1.00	22.00	40.00	4.00
4.022	GE104.0100.000.27.40.R	4.00	1.00	1.70	3.70	1.00	27.00	45.00	4.00
4.023	GE104.0100.000.32.40.R	4.00	1.00	1.70	3.70	1.00	32.00	50.00	4.00
4.024	GE104.0150.000.12.40.R	4.00	1.50	1.70	3.70	1.00	12.00	30.00	4.00
4.025	GE104.0150.000.17.40.R	4.00	1.50	1.70	3.70	1.00	17.00	35.00	4.00
4.026	GE104.0150.000.22.40.R	4.00	1.50	1.70	3.70	1.00	22.00	40.00	4.00
4.027	GE104.0150.000.27.40.R	4.00	1.50	1.70	3.70	1.00	27.00	45.00	4.00
4.028	GE104.0150.000.32.40.R	4.00	1.50	1.70	3.70	1.00	32.00	50.00	4.00

Series no. **25125** **25127** **25131**Cutting direction   

Code no.	Description	D min	b	f	a	t max	La	Lg	D h6
		mm	mm	mm	mm	mm	mm	mm	mm
4.001	GE104.0030.000.04.10.L	1.00	0.30	1.95	0.85	0.20	4.00	25.00	4.00
4.002	GE104.0030.000.07.10.L	1.00	0.30	1.95	0.85	0.20	7.00	25.00	4.00
4.003	GE104.0040.000.04.15.L	1.50	0.40	1.95	1.30	0.40	4.00	25.00	4.00
4.004	GE104.0040.000.07.15.L	1.50	0.40	1.95	1.30	0.40	7.00	25.00	4.00
4.005	GE104.0040.000.12.15.L	1.50	0.40	1.95	1.30	0.40	12.00	30.00	4.00
4.006	GE104.0050.000.04.20.L	2.00	0.50	1.95	1.80	0.50	4.00	25.00	4.00
4.007	GE104.0050.000.07.20.L	2.00	0.50	1.95	1.80	0.50	7.00	25.00	4.00
4.008	GE104.0050.000.12.20.L	2.00	0.50	1.95	1.80	0.50	12.00	30.00	4.00
4.009	GE104.0050.000.17.20.L	2.00	0.50	1.95	1.80	0.50	17.00	35.00	4.00
4.010	GE104.0070.000.07.30.L	3.00	0.70	1.95	2.70	0.70	7.00	25.00	4.00
4.011	GE104.0070.000.12.30.L	3.00	0.70	1.95	2.70	0.70	12.00	30.00	4.00
4.012	GE104.0070.000.17.30.L	3.00	0.70	1.95	2.70	0.70	17.00	35.00	4.00
4.013	GE104.0070.000.22.30.L	3.00	0.70	1.95	2.70	0.70	22.00	40.00	4.00
4.014	GE104.0079.000.12.40.L	4.00	0.79	1.70	3.70	1.00	12.00	30.00	4.00
4.015	GE104.0079.000.17.40.L	4.00	0.79	1.70	3.70	1.00	17.00	35.00	4.00
4.016	GE104.0079.000.22.40.L	4.00	0.79	1.70	3.70	1.00	22.00	40.00	4.00
4.017	GE104.0079.000.27.40.L	4.00	0.79	1.70	3.70	1.00	27.00	45.00	4.00
4.018	GE104.0079.000.32.40.L	4.00	0.79	1.70	3.70	1.00	32.00	50.00	4.00
4.019	GE104.0100.000.12.40.L	4.00	1.00	1.70	3.70	1.00	12.00	30.00	4.00
4.020	GE104.0100.000.17.40.L	4.00	1.00	1.70	3.70	1.00	17.00	35.00	4.00
4.021	GE104.0100.000.22.40.L	4.00	1.00	1.70	3.70	1.00	22.00	40.00	4.00
4.022	GE104.0100.000.27.40.L	4.00	1.00	1.70	3.70	1.00	27.00	45.00	4.00
4.023	GE104.0100.000.32.40.L	4.00	1.00	1.70	3.70	1.00	32.00	50.00	4.00
4.024	GE104.0150.000.12.40.L	4.00	1.50	1.70	3.70	1.00	12.00	30.00	4.00
4.025	GE104.0150.000.17.40.L	4.00	1.50	1.70	3.70	1.00	17.00	35.00	4.00
4.026	GE104.0150.000.22.40.L	4.00	1.50	1.70	3.70	1.00	22.00	40.00	4.00
4.027	GE104.0150.000.27.40.L	4.00	1.50	1.70	3.70	1.00	27.00	45.00	4.00
4.028	GE104.0150.000.32.40.L	4.00	1.50	1.70	3.70	1.00	32.00	50.00	4.00



Cutting insert for internal grooving, full radius slots

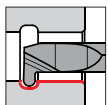

- full radius R0.4-R0.58

for tool holders type GH104/GB104 see from page 16

Cutting data page 148

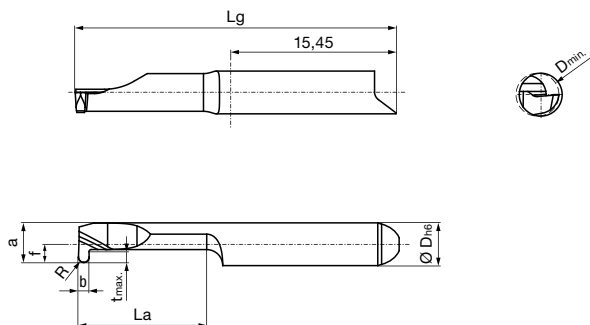

Right hand version shown
Left hand version mirror image

Tool material	Solid carbide		
Type	GE 104	GE 104	GE 104
Surface	S	a	○
	TiN	TiAlN-nanoA	bright



Series no.	25132	25134	25138
Cutting direction	(R)	(R)	(R)

Code no.	Description	D min	b	R	f	a	t max	La	Lg	D h6
		mm	mm	mm	mm	mm	mm	mm	mm	mm
4.001	GE104.0080.040.07.30.R	3.00	0.80	0.40	1.95	2.70	0.70	7.00	25.00	4.00
4.002	GE104.0080.040.12.30.R	3.00	0.80	0.40	1.95	2.70	0.70	12.00	30.00	4.00
4.003	GE104.0080.040.17.30.R	3.00	0.80	0.40	1.95	2.70	0.70	17.00	35.00	4.00
4.004	GE104.0080.040.22.30.R	3.00	0.80	0.40	1.95	2.70	0.70	22.00	40.00	4.00
4.005	GE104.0100.050.12.40.R	4.00	1.00	0.50	1.70	3.70	1.00	12.00	30.00	4.00
4.006	GE104.0100.050.17.40.R	4.00	1.00	0.50	1.70	3.70	1.00	17.00	35.00	4.00
4.007	GE104.0100.050.22.40.R	4.00	1.00	0.50	1.70	3.70	1.00	22.00	40.00	4.00
4.008	GE104.0100.050.27.40.R	4.00	1.00	0.50	1.70	3.70	1.00	27.00	45.00	4.00
4.009	GE104.0100.050.32.40.R	4.00	1.00	0.50	1.70	3.70	1.00	32.00	50.00	4.00
4.010	GE104.0117.058.12.40.R	4.00	1.17	0.58	1.70	3.70	1.00	12.00	30.00	4.00
4.011	GE104.0117.058.17.40.R	4.00	1.17	0.58	1.70	3.70	1.00	17.00	35.00	4.00
4.012	GE104.0117.058.22.40.R	4.00	1.17	0.58	1.70	3.70	1.00	22.00	40.00	4.00
4.013	GE104.0117.058.27.40.R	4.00	1.17	0.58	1.70	3.70	1.00	27.00	45.00	4.00
4.014	GE104.0117.058.32.40.R	4.00	1.17	0.58	1.70	3.70	1.00	32.00	50.00	4.00

Series no.	25133	25135	25139
Cutting direction	(L)	(L)	(L)

Code no.	Description	D min	b	R	f	a	t max	La	Lg	D h6
		mm	mm	mm	mm	mm	mm	mm	mm	mm
4.001	GE104.0080.040.07.30.L	3.00	0.80	0.40	1.95	2.70	0.70	7.00	25.00	4.00
4.002	GE104.0080.040.12.30.L	3.00	0.80	0.40	1.95	2.70	0.70	12.00	30.00	4.00
4.003	GE104.0080.040.17.30.L	3.00	0.80	0.40	1.95	2.70	0.70	17.00	35.00	4.00
4.004	GE104.0080.040.22.30.L	3.00	0.80	0.40	1.95	2.70	0.70	22.00	40.00	4.00
4.005	GE104.0100.050.12.40.L	4.00	1.00	0.50	1.70	3.70	1.00	12.00	30.00	4.00
4.006	GE104.0100.050.17.40.L	4.00	1.00	0.50	1.70	3.70	1.00	17.00	35.00	4.00
4.007	GE104.0100.050.22.40.L	4.00	1.00	0.50	1.70	3.70	1.00	22.00	40.00	4.00
4.008	GE104.0100.050.27.40.L	4.00	1.00	0.50	1.70	3.70	1.00	27.00	45.00	4.00
4.009	GE104.0100.050.32.40.L	4.00	1.00	0.50	1.70	3.70	1.00	32.00	50.00	4.00
4.010	GE104.0117.058.12.40.L	4.00	1.17	0.58	1.70	3.70	1.00	12.00	30.00	4.00
4.011	GE104.0117.058.17.40.L	4.00	1.17	0.58	1.70	3.70	1.00	17.00	35.00	4.00
4.012	GE104.0117.058.22.40.L	4.00	1.17	0.58	1.70	3.70	1.00	22.00	40.00	4.00
4.013	GE104.0117.058.27.40.L	4.00	1.17	0.58	1.70	3.70	1.00	27.00	45.00	4.00
4.014	GE104.0117.058.32.40.L	4.00	1.17	0.58	1.70	3.70	1.00	32.00	50.00	4.00



Cutting insert for internal pre-grooving and chamfering

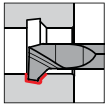

• 45° chamfer

for tool holders type GH104/GB104 see from page 16

Cutting data page 148

Tool material	Solid carbide		
Type	GV 104	GV 104	GV 104
Surface	S	a	○
	TiN	TiAlN-nanoA	bright

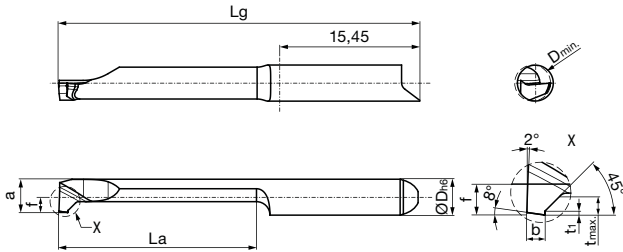

Right hand version shown
Left hand version mirror image



Series no.	25140	25142	25146
Cutting direction	(R)	(R)	(R)

Code no.	Description	D min	b	f	t1	a	t max	La	Lg	D h6
		mm	mm	mm	mm	mm	mm	mm	mm	mm
4.001	GV104.0807.045.04.20.R	2.00	0.70	1.95	0.20	1.80	0.50	4.00	25.00	4.00
4.002	GV104.0807.045.07.20.R	2.00	0.70	1.95	0.20	1.80	0.50	7.00	25.00	4.00
4.003	GV104.0807.045.12.20.R	2.00	0.70	1.95	0.20	1.80	0.50	12.00	30.00	4.00
4.004	GV104.0807.045.17.20.R	2.00	0.70	1.95	0.20	1.80	0.50	17.00	35.00	4.00
4.005	GV104.0807.045.07.30.R	3.00	0.70	1.95	0.20	2.70	0.70	7.00	25.00	4.00
4.006	GV104.0807.045.12.30.R	3.00	0.70	1.95	0.20	2.70	0.70	12.00	30.00	4.00
4.007	GV104.0807.045.17.30.R	3.00	0.70	1.95	0.20	2.70	0.70	17.00	35.00	4.00
4.008	GV104.0807.045.22.30.R	3.00	0.70	1.95	0.20	2.70	0.70	22.00	40.00	4.00
4.009	GV104.0810.045.12.40.R	4.00	1.00	1.70	0.20	3.70	1.00	12.00	30.00	4.00
4.010	GV104.0810.045.17.40.R	4.00	1.00	1.70	0.20	3.70	1.00	17.00	35.00	4.00
4.011	GV104.0810.045.22.40.R	4.00	1.00	1.70	0.20	3.70	1.00	22.00	40.00	4.00
4.012	GV104.0810.045.27.40.R	4.00	1.00	1.70	0.20	3.70	1.00	27.00	45.00	4.00
4.013	GV104.0810.045.32.40.R	4.00	1.00	1.70	0.20	3.70	1.00	32.00	50.00	4.00

Series no.	25141	25143	25147
Cutting direction	(L)	(L)	(L)

Code no.	Description	D min	b	f	t1	a	t max	La	Lg	D h6
		mm	mm	mm	mm	mm	mm	mm	mm	mm
4.001	GV104.0807.045.04.20.L	2.00	0.70	1.95	0.20	1.80	0.50	4.00	25.00	4.00
4.002	GV104.0807.045.07.20.L	2.00	0.70	1.95	0.20	1.80	0.50	7.00	25.00	4.00
4.003	GV104.0807.045.12.20.L	2.00	0.70	1.95	0.20	1.80	0.50	12.00	30.00	4.00
4.004	GV104.0807.045.17.20.L	2.00	0.70	1.95	0.20	1.80	0.50	17.00	35.00	4.00
4.005	GV104.0807.045.07.30.L	3.00	0.70	1.95	0.20	2.70	0.70	7.00	25.00	4.00
4.006	GV104.0807.045.12.30.L	3.00	0.70	1.95	0.20	2.70	0.70	12.00	30.00	4.00
4.007	GV104.0807.045.17.30.L	3.00	0.70	1.95	0.20	2.70	0.70	17.00	35.00	4.00
4.008	GV104.0807.045.22.30.L	3.00	0.70	1.95	0.20	2.70	0.70	22.00	40.00	4.00
4.009	GV104.0810.045.12.40.L	4.00	1.00	1.70	0.20	3.70	1.00	12.00	30.00	4.00
4.010	GV104.0810.045.17.40.L	4.00	1.00	1.70	0.20	3.70	1.00	17.00	35.00	4.00
4.011	GV104.0810.045.22.40.L	4.00	1.00	1.70	0.20	3.70	1.00	22.00	40.00	4.00
4.012	GV104.0810.045.27.40.L	4.00	1.00	1.70	0.20	3.70	1.00	27.00	45.00	4.00
4.013	GV104.0810.045.32.40.L	4.00	1.00	1.70	0.20	3.70	1.00	32.00	50.00	4.00



Cutting insert for axial grooving bores, straight slots

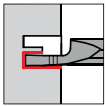

- grooving depth up to 5 mm

for tool holders type GH104/GB104 see from page 16

Tool material	Solid carbide		
Type	GA 104	GA 104	GA 104
Surface			
	TiN	TiAlN-nanoA	bright

Cutting data page 148

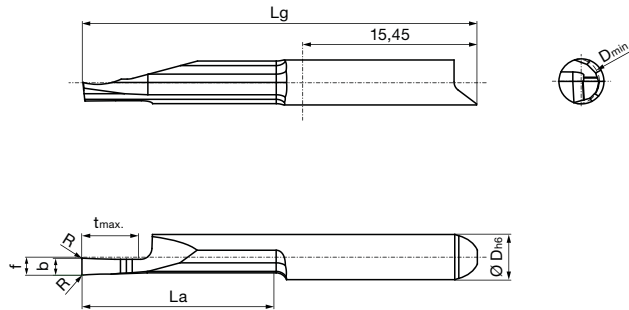

Right hand version shown
Left hand version mirror image

Series no.	25188	25190	25194
Cutting direction			

Code no.	Description	D min	b	R	f	t max	La	Lg	D h6
		mm	mm	mm	mm	mm	mm	mm	mm
4.001	GA104.0100.005.12.40.R	4.00	1.00	0.05	1.60	2.00	12.00	30.00	4.00
4.002	GA104.0100.005.17.40.R	4.00	1.00	0.05	1.60	2.00	17.00	35.00	4.00
4.003	GA104.0150.005.12.40.R	4.00	1.50	0.05	1.60	3.00	12.00	30.00	4.00
4.004	GA104.0150.005.17.40.R	4.00	1.50	0.05	1.60	3.00	17.00	35.00	4.00
4.005	GA104.0200.005.12.50.R	5.00	2.00	0.05	1.60	5.00	12.00	30.00	4.00
4.006	GA104.0200.005.17.50.R	5.00	2.00	0.05	1.60	5.00	17.00	35.00	4.00

Series no.	25189	25191	25195
Cutting direction			

Code no.	Description	D min	b	R	f	t max	La	Lg	D h6
		mm	mm	mm	mm	mm	mm	mm	mm
4.001	GA104.0100.005.12.40.L	4.00	1.00	0.05	1.60	2.00	12.00	30.00	4.00
4.002	GA104.0100.005.17.40.L	4.00	1.00	0.05	1.60	2.00	17.00	35.00	4.00
4.003	GA104.0150.005.12.40.L	4.00	1.50	0.05	1.60	3.00	12.00	30.00	4.00
4.004	GA104.0150.005.17.40.L	4.00	1.50	0.05	1.60	3.00	17.00	35.00	4.00
4.005	GA104.0200.005.12.50.L	5.00	2.00	0.05	1.60	5.00	12.00	30.00	4.00
4.006	GA104.0200.005.17.50.L	5.00	2.00	0.05	1.60	5.00	17.00	35.00	4.00



Cutting insert for axial grooving bores, full radius slots

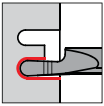

- grooving depth up to 5 mm

for tool holders type GH104/GB104 see from page 16

Tool material	Solid carbide		
Type	GA 104	GA 104	GA 104
Surface			
	TiN	TiAlN-nanoA	bright

Cutting data page 148

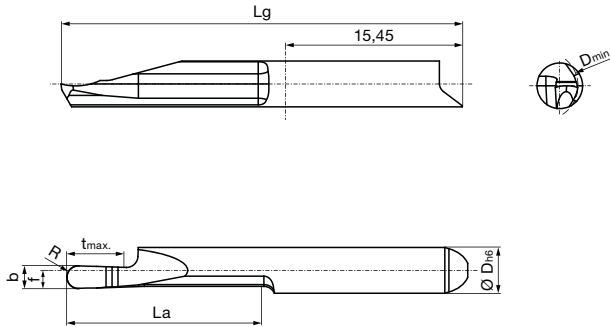

Right hand version shown
Left hand version mirror image



Series no.	25196	25198	25202
Cutting direction			

Code no.	Description	D min	b	R	f	t max	La	Lg	D h6
		mm	mm	mm	mm	mm	mm	mm	mm
4.001	GA104.0100.050.12.60.R	6.00	1.00	0.50	1.60	2.00	12.00	30.00	4.00
4.002	GA104.0100.050.17.60.R	6.00	1.00	0.50	1.60	2.00	17.00	35.00	4.00
4.003	GA104.0150.075.12.60.R	6.00	1.50	0.75	1.60	3.00	12.00	30.00	4.00
4.004	GA104.0150.075.17.60.R	6.00	1.50	0.75	1.60	3.00	17.00	35.00	4.00
4.005	GA104.0200.100.12.60.R	6.00	2.00	1.00	1.60	5.00	12.00	30.00	4.00
4.006	GA104.0200.100.17.60.R	6.00	2.00	1.00	1.60	5.00	17.00	35.00	4.00

Series no.	25197	25199	25203
Cutting direction			

Code no.	Description	D min	b	R	f	t max	La	Lg	D h6
		mm	mm	mm	mm	mm	mm	mm	mm
4.001	GA104.0100.050.12.60.L	6.00	1.00	0.50	1.60	2.00	12.00	30.00	4.00
4.002	GA104.0100.050.17.60.L	6.00	1.00	0.50	1.60	2.00	17.00	35.00	4.00
4.003	GA104.0150.075.12.60.L	6.00	1.50	0.75	1.60	3.00	12.00	30.00	4.00
4.004	GA104.0150.075.17.60.L	6.00	1.50	0.75	1.60	3.00	17.00	35.00	4.00
4.005	GA104.0200.100.12.60.L	6.00	2.00	1.00	1.60	5.00	12.00	30.00	4.00
4.006	GA104.0200.100.17.60.L	6.00	2.00	1.00	1.60	5.00	17.00	35.00	4.00



Cutting insert for axial grooving studs, straight slots



- grooving depth up to 5 mm

for tool holders type GH104/GB104 see from page 16

Tool material	Solid carbide		
Type	GA 104	GA 104	GA 104
Surface			
	TiN	TiAlN-nanoA	bright

Cutting data page 148

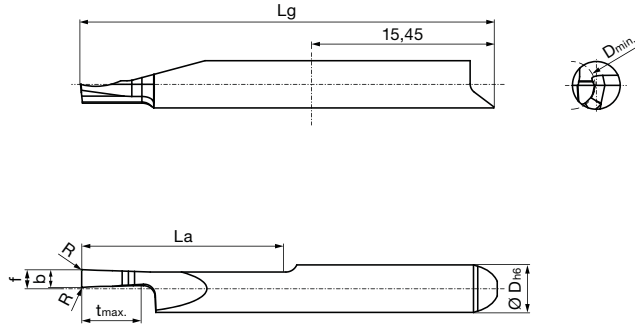

Right hand version shown
Left hand version mirror image



Series no.	25204	25206	25210
Cutting direction			

Code no.	Description	D min	b	R	f	t max	La	Lg	D h6
		mm	mm	mm	mm	mm	mm	mm	mm
4.001	GA104.Z100.005.12.40.R	4.00	1.00	0.05	1.60	2.00	12.00	30.00	4.00
4.002	GA104.Z100.005.17.40.R	4.00	1.00	0.05	1.60	2.00	17.00	35.00	4.00
4.003	GA104.Z150.005.12.40.R	4.00	1.50	0.05	1.60	3.00	12.00	30.00	4.00
4.004	GA104.Z150.005.17.40.R	4.00	1.50	0.05	1.60	3.00	17.00	35.00	4.00
4.005	GA104.Z200.005.12.50.R	5.00	2.00	0.05	1.60	5.00	12.00	30.00	4.00
4.006	GA104.Z200.005.17.50.R	5.00	2.00	0.05	1.60	5.00	17.00	35.00	4.00

Series no.	25205	25207	25211
Cutting direction			

Code no.	Description	D min	b	R	f	t max	La	Lg	D h6
		mm	mm	mm	mm	mm	mm	mm	mm
4.001	GA104.Z100.005.12.40.L	4.00	1.00	0.05	1.60	2.00	12.00	30.00	4.00
4.002	GA104.Z100.005.17.40.L	4.00	1.00	0.05	1.60	2.00	17.00	35.00	4.00
4.003	GA104.Z150.005.12.40.L	4.00	1.50	0.05	1.60	3.00	12.00	30.00	4.00
4.004	GA104.Z150.005.17.40.L	4.00	1.50	0.05	1.60	3.00	17.00	35.00	4.00
4.005	GA104.Z200.005.12.50.L	5.00	2.00	0.05	1.60	5.00	12.00	30.00	4.00
4.006	GA104.Z200.005.17.50.L	5.00	2.00	0.05	1.60	5.00	17.00	35.00	4.00



Cutting insert for axial grooving studs, full radius slots

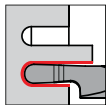

• grooving depth up to 5 mm

for tool holders type GH104/GB104 see from page 16

Cutting data page 148

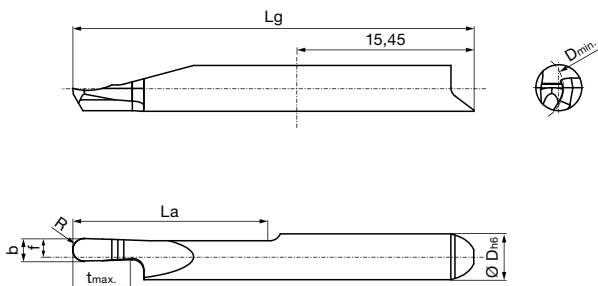

Right hand version shown
Left hand version mirror image

Tool material		Solid carbide		
Type	GA 104	GA 104	GA 104	
Surface				
	TiN	TiAlN-nanoA	bright	



Series no. **25212** **25214** **25218**

Cutting direction

Code no.	Description	D min	b	R	f	t max	La	Lg	D h6
		mm	mm	mm	mm	mm	mm	mm	mm
4.001	GA104.Z100.050.12.60.R	6.00	1.00	0.50	1.60	2.00	12.00	30.00	4.00
4.002	GA104.Z100.050.17.60.R	6.00	1.00	0.50	1.60	2.00	17.00	35.00	4.00
4.003	GA104.Z150.075.12.60.R	6.00	1.50	0.75	1.60	3.00	12.00	30.00	4.00
4.004	GA104.Z150.075.17.60.R	6.00	1.50	0.75	1.60	3.00	17.00	35.00	4.00
4.005	GA104.Z200.100.12.60.R	6.00	2.00	1.00	1.60	5.00	12.00	30.00	4.00
4.006	GA104.Z200.100.17.60.R	6.00	2.00	1.00	1.60	5.00	17.00	35.00	4.00

Series no. **25213** **25215** **25219**

Cutting direction

Code no.	Description	D min	b	R	f	t max	La	Lg	D h6
		mm	mm	mm	mm	mm	mm	mm	mm
4.001	GA104.Z100.050.12.60.L	6.00	1.00	0.50	1.60	2.00	12.00	30.00	4.00
4.002	GA104.Z100.050.17.60.L	6.00	1.00	0.50	1.60	2.00	17.00	35.00	4.00
4.003	GA104.Z150.075.12.60.L	6.00	1.50	0.75	1.60	3.00	12.00	30.00	4.00
4.004	GA104.Z150.075.17.60.L	6.00	1.50	0.75	1.60	3.00	17.00	35.00	4.00
4.005	GA104.Z200.100.12.60.L	6.00	2.00	1.00	1.60	5.00	12.00	30.00	4.00
4.006	GA104.Z200.100.17.60.L	6.00	2.00	1.00	1.60	5.00	17.00	35.00	4.00



Cutting insert for axial chamfering bores

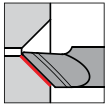

- 45°/60°/75° chamfer angle

for tool holders type GH104/GB104 see from page 16

Tool material	Solid carbide		
Type	GA 104	GA 104	GA 104
Surface			
	TiN	TiAlN-nanoA	bright

Cutting data page 148

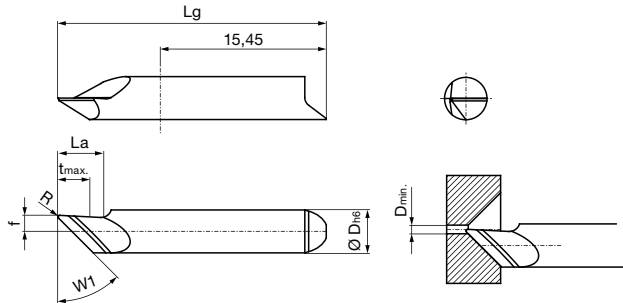

Right hand version shown
Left hand version mirror image



Series no.	25220	25222	25226
Cutting direction			

Code no.	Description	D min	R	W1	f	t max	La	Lg	D h6
		mm	mm	°	mm	mm	mm	mm	mm
4.001	GA104.F045.015.04.08.R	0.80	0.15	45.00	1.50	3.00	4.00	25.00	4.00
4.002	GA104.F060.015.04.08.R	0.80	0.15	60.00	0.50	3.50	4.00	25.00	4.00
4.003	GA104.F075.015.04.08.R	0.80	0.15	75.00	0.50	2.00	4.00	25.00	4.00

Series no.	25221	25223	25227
Cutting direction			

Code no.	Description	D min	R	W1	f	t max	La	Lg	D h6
		mm	mm	°	mm	mm	mm	mm	mm
4.001	GA104.F045.015.04.08.L	0.80	0.15	45.00	1.50	3.00	4.00	25.00	4.00
4.002	GA104.F060.015.04.08.L	0.80	0.15	60.00	0.50	3.50	4.00	25.00	4.00
4.003	GA104.F075.015.04.08.L	0.80	0.15	75.00	0.50	2.00	4.00	25.00	4.00



Cutting insert for internal threading, partial profile - metric standard threads

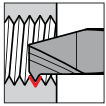

• pitch P = 0.4-1.0

for tool holders type GH104/GB104 see from page 16

Cutting data page 148

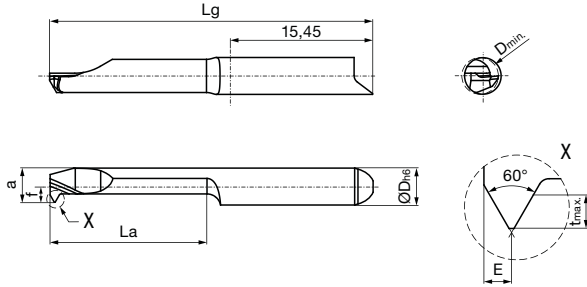

Right hand version shown
Left hand version mirror image

Tool material	Solid carbide			
	Type	GG 104	GG 104	GG 104
Surface				
	TiN	TiAlN-nanoA	bright	



Series no. **25148** **25150** **25154**

Cutting direction

Code no.	Description	G	P	D min	f	t max	a	E	La	Lg	D h6
				mm	mm	mm	mm	mm	mm	mm	mm
4.001	GG104.TM02.040.04.15.R	M2/M2.5	0.40-0.45	1.50	1.95	0.25	1.40	0.25	4.00	25.00	4.00
4.002	GG104.TM02.040.07.15.R	M2/M2.5	0.40-0.45	1.50	1.95	0.25	1.40	0.25	7.00	25.00	4.00
4.003	GG104.TM02.040.12.15.R	M2/M2.5	0.40-0.45	1.50	1.95	0.25	1.40	0.25	12.00	30.00	4.00
4.004	GG104.TM03.050.04.25.R	M3	0.50	2.50	1.95	0.30	2.20	0.30	4.00	25.00	4.00
4.005	GG104.TM03.050.07.25.R	M3	0.50	2.50	1.95	0.30	2.20	0.30	7.00	25.00	4.00
4.006	GG104.TM03.050.12.25.R	M3	0.50	2.50	1.95	0.30	2.20	0.30	12.00	30.00	4.00
4.007	GG104.TM04.070.07.33.R	M4	0.70	3.30	1.95	0.40	3.00	0.40	7.00	25.00	4.00
4.008	GG104.TM04.070.12.33.R	M4	0.70	3.30	1.95	0.40	3.00	0.40	12.00	30.00	4.00
4.009	GG104.TM04.070.17.33.R	M4	0.70	3.30	1.95	0.40	3.00	0.40	17.00	35.00	4.00
4.010	GG104.TM05.080.12.40.R	M5/M6	0.80-1.00	4.00	1.70	0.60	3.70	0.50	12.00	30.00	4.00
4.011	GG104.TM05.080.17.40.R	M5/M6	0.80-1.00	4.00	1.70	0.60	3.70	0.50	17.00	35.00	4.00
4.012	GG104.TM05.080.22.40.R	M5/M6	0.80-1.00	4.00	1.70	0.60	3.70	0.50	22.00	40.00	4.00

Series no. **25149** **25151** **25155**

Cutting direction

Code no.	Description	G	P	D min	f	t max	a	E	La	Lg	D h6
				mm	mm	mm	mm	mm	mm	mm	mm
4.001	GG104.TM02.040.04.15.L	M2/M2.5	0.40-0.45	1.50	1.95	0.25	1.40	0.25	4.00	25.00	4.00
4.002	GG104.TM02.040.07.15.L	M2/M2.5	0.40-0.45	1.50	1.95	0.25	1.40	0.25	7.00	25.00	4.00
4.003	GG104.TM02.040.12.15.L	M2/M2.5	0.40-0.45	1.50	1.95	0.25	1.40	0.25	12.00	30.00	4.00
4.004	GG104.TM03.050.04.25.L	M3	0.50	2.50	1.95	0.30	2.20	0.30	4.00	25.00	4.00
4.005	GG104.TM03.050.07.25.L	M3	0.50	2.50	1.95	0.30	2.20	0.30	7.00	25.00	4.00
4.006	GG104.TM03.050.12.25.L	M3	0.50	2.50	1.95	0.30	2.20	0.30	12.00	30.00	4.00
4.007	GG104.TM04.070.07.33.L	M4	0.70	3.30	1.95	0.40	3.00	0.40	7.00	25.00	4.00
4.008	GG104.TM04.070.12.33.L	M4	0.70	3.30	1.95	0.40	3.00	0.40	12.00	30.00	4.00
4.009	GG104.TM04.070.17.33.L	M4	0.70	3.30	1.95	0.40	3.00	0.40	17.00	35.00	4.00
4.010	GG104.TM05.080.12.40.L	M5/M6	0.80-1.00	4.00	1.70	0.60	3.70	0.50	12.00	30.00	4.00
4.011	GG104.TM05.080.17.40.L	M5/M6	0.80-1.00	4.00	1.70	0.60	3.70	0.50	17.00	35.00	4.00
4.012	GG104.TM05.080.22.40.L	M5/M6	0.80-1.00	4.00	1.70	0.60	3.70	0.50	22.00	40.00	4.00



Cutting insert for internal threading, partial profile - metric fine threads

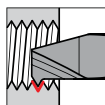

• pitch P = 0.2-0.5

for tool holders type GH104/GB104 see from page 16

Tool material	Solid carbide		
Type	GG 104	GG 104	GG 104
Surface	S	a	○
	TiN	TiAlN-nanoA	bright

Cutting data page 148

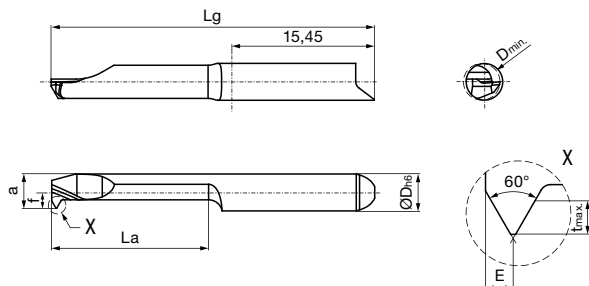

Right hand version shown
Left hand version mirror image



Series no.	25156	25158	25162
Cutting direction	R	R	R

Code no.	Description	G	P	D min	f	t max	a	E	La	Lg	D h6
				mm	mm	mm	mm	mm	mm	mm	mm
4.001	GG104.TM02.020.04.17.R	M2/M3	0.20-0.30	1.70	1.95	0.20	1.55	0.20	4.00	25.00	4.00
4.002	GG104.TM02.020.07.17.R	M2/M3	0.20-0.30	1.70	1.95	0.20	1.55	0.20	7.00	25.00	4.00
4.003	GG104.TM02.020.12.17.R	M2/M3	0.20-0.30	1.70	1.95	0.20	1.55	0.20	12.00	30.00	4.00
4.004	GG104.TM04.035.07.35.R	M4/M5	0.35-0.50	3.50	1.95	0.30	3.20	0.35	7.00	25.00	4.00
4.005	GG104.TM04.035.12.35.R	M4/M5	0.35-0.50	3.50	1.95	0.30	3.20	0.35	12.00	30.00	4.00
4.006	GG104.TM04.035.17.35.R	M4/M5	0.35-0.50	3.50	1.95	0.30	3.20	0.35	17.00	35.00	4.00

Series no.	25157	25159	25163
Cutting direction	L	L	L

Code no.	Description	G	P	D min	f	t max	a	E	La	Lg	D h6
				mm	mm	mm	mm	mm	mm	mm	mm
4.001	GG104.TM02.020.04.17.L	M2/M3	0.20-0.30	1.70	1.95	0.20	1.55	0.20	4.00	25.00	4.00
4.002	GG104.TM02.020.07.17.L	M2/M3	0.20-0.30	1.70	1.95	0.20	1.55	0.20	7.00	25.00	4.00
4.003	GG104.TM02.020.12.17.L	M2/M3	0.20-0.30	1.70	1.95	0.20	1.55	0.20	12.00	30.00	4.00
4.004	GG104.TM04.035.07.35.L	M4/M5	0.35-0.50	3.50	1.95	0.30	3.20	0.35	7.00	25.00	4.00
4.005	GG104.TM04.035.12.35.L	M4/M5	0.35-0.50	3.50	1.95	0.30	3.20	0.35	12.00	30.00	4.00
4.006	GG104.TM04.035.17.35.L	M4/M5	0.35-0.50	3.50	1.95	0.30	3.20	0.35	17.00	35.00	4.00



Cutting insert for internal threading, full profile - metric standard threads

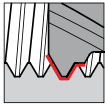

• pitch P = 0.4-0.8

for tool holders type GH104/GB104 see from page 16

Cutting data page 148

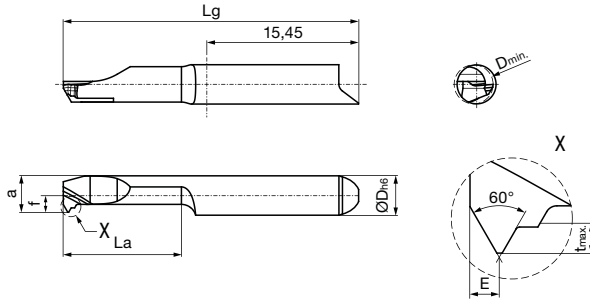

Right hand version shown
Left hand version mirror image

Tool material	Solid carbide		
	GG 104	GG 104	GG 104
Type			
Surface	S TiN	a TiAlN-nanoA	○ bright



Series no. **25164** **25166** **25170**

Cutting direction **(R)** **(R)** **(R)**

Code no.	Description	G	P	D min	f	E	a	t max	La	Lg	D h6
			mm								
4.001	GG104.VM02.040.04.15.R	M2	0.40	1.50	1.95	0.20	1.35	0.25	4.00	25.00	4.00
4.002	GG104.VM02.040.07.15.R	M2	0.40	1.50	1.95	0.20	1.35	0.25	7.00	25.00	4.00
4.003	GG104.VM02.040.12.15.R	M2	0.40	1.50	1.95	0.20	1.35	0.25	12.00	30.00	4.00
4.004	GG104.VM03.050.04.24.R	M3	0.50	2.40	1.95	0.30	1.95	0.35	4.00	25.00	4.00
4.005	GG104.VM03.050.07.24.R	M3	0.50	2.40	1.95	0.30	1.95	0.35	7.00	25.00	4.00
4.006	GG104.VM03.050.12.24.R	M3	0.50	2.40	1.95	0.30	1.95	0.35	12.00	30.00	4.00
4.007	GG104.VM04.070.07.31.R	M4	0.70	3.10	1.95	0.40	2.80	0.45	7.00	25.00	4.00
4.008	GG104.VM04.070.12.31.R	M4	0.70	3.10	1.95	0.40	2.80	0.45	12.00	30.00	4.00
4.009	GG104.VM04.070.17.31.R	M4	0.70	3.10	1.95	0.40	2.80	0.45	17.00	35.00	4.00
4.010	GG104.VM04.070.22.31.R	M4	0.70	3.10	1.95	0.40	2.80	0.45	22.00	40.00	4.00
4.011	GG104.VM05.080.12.40.R	M5	0.80	4.00	1.70	0.50	3.70	0.50	12.00	30.00	4.00
4.012	GG104.VM05.080.17.40.R	M5	0.80	4.00	1.70	0.50	3.70	0.50	17.00	35.00	4.00
4.013	GG104.VM05.080.22.40.R	M5	0.80	4.00	1.70	0.50	3.70	0.50	22.00	40.00	4.00
4.014	GG104.VM05.080.27.40.R	M5	0.80	4.00	1.70	0.50	3.70	0.50	27.00	45.00	4.00

Series no. **25165** **25167** **25171**

Cutting direction **(L)** **(L)** **(L)**

Code no.	Description	G	P	D min	f	E	a	t max	La	Lg	D h6
			mm								
4.001	GG104.VM02.040.04.15.L	M2	0.40	1.50	1.95	0.20	1.35	0.25	4.00	25.00	4.00
4.002	GG104.VM02.040.07.15.L	M2	0.40	1.50	1.95	0.20	1.35	0.25	7.00	25.00	4.00
4.003	GG104.VM02.040.12.15.L	M2	0.40	1.50	1.95	0.20	1.35	0.25	12.00	30.00	4.00
4.004	GG104.VM03.050.04.24.L	M3	0.50	2.40	1.95	0.30	1.95	0.35	4.00	25.00	4.00
4.005	GG104.VM03.050.07.24.L	M3	0.50	2.40	1.95	0.30	1.95	0.35	7.00	25.00	4.00
4.006	GG104.VM03.050.12.24.L	M3	0.50	2.40	1.95	0.30	1.95	0.35	12.00	30.00	4.00
4.007	GG104.VM04.070.07.31.L	M4	0.70	3.10	1.95	0.40	2.80	0.45	7.00	25.00	4.00
4.008	GG104.VM04.070.12.31.L	M4	0.70	3.10	1.95	0.40	2.80	0.45	12.00	30.00	4.00
4.009	GG104.VM04.070.17.31.L	M4	0.70	3.10	1.95	0.40	2.80	0.45	17.00	35.00	4.00
4.010	GG104.VM04.070.22.31.L	M4	0.70	3.10	1.95	0.40	2.80	0.45	22.00	40.00	4.00
4.011	GG104.VM05.080.12.40.L	M5	0.80	4.00	1.70	0.50	3.70	0.50	12.00	30.00	4.00
4.012	GG104.VM05.080.17.40.L	M5	0.80	4.00	1.70	0.50	3.70	0.50	17.00	35.00	4.00
4.013	GG104.VM05.080.22.40.L	M5	0.80	4.00	1.70	0.50	3.70	0.50	22.00	40.00	4.00
4.014	GG104.VM05.080.27.40.L	M5	0.80	4.00	1.70	0.50	3.70	0.50	27.00	45.00	4.00



Cutting insert for internal threading, partial profile - UN-threads

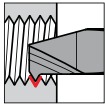

- pitch 32-40 thread/inch

for tool holders type GH104/GB104 see from page 16

Tool material	Solid carbide		
Type	GG 104	GG 104	GG 104
Surface	S	a	○
	TiN	TiAlN-nanoA	bright

Cutting data page 148

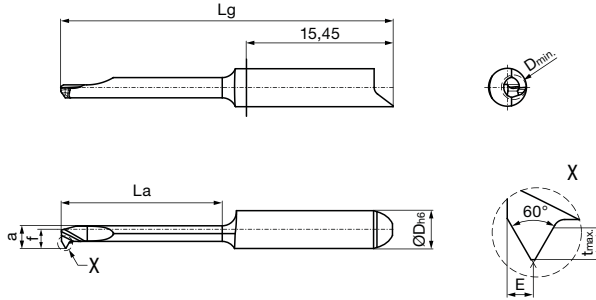

Right hand version shown
Left hand version mirror image

Series no.	25172	25174	25178
Cutting direction	R	R	R

Code no.	Description	P	D min	f	t max	a	E	La	Lg	D h6
		Thread/inch	mm	mm	mm	mm	mm	mm	mm	mm
4.001	GG104.TU32.040.17.26.R	32-40	2.60	1.95	0.55	2.35	0.45	17.00	35.00	4.00

Series no.	25173	25175	25179
Cutting direction	L	L	L

Code no.	Description	P	D min	f	t max	a	E	La	Lg	D h6
		Thread/inch	mm	mm	mm	mm	mm	mm	mm	mm
4.001	GG104.TU32.040.17.26.L	32-40	2.60	1.95	0.55	2.35	0.45	17.00	35.00	4.00



Cutting insert for internal threading, full profile - Whitworth pipe threads

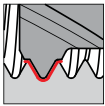

• pitch 24-28 thread/inch

for tool holders type GH104/GB104 see from page 16

Cutting data page 148

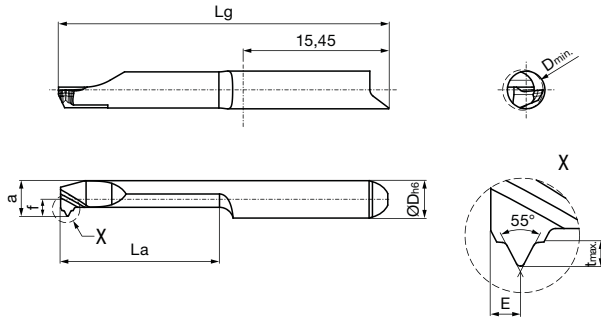

Right hand version shown
Left hand version mirror image

Tool material	Solid carbide		
Type	GG 104	GG 104	GG 104
Surface			
	TiN	TiAlN-nanoA	bright



Series no. **25180** **25182** **25186**

Cutting direction

Code no.	Description	P	D min	f	t max	a	E	La	Lg	D h6
		Thread/inch	mm	mm	mm	mm	mm	mm	mm	mm
4.003	GG104.VW24.106.17.33.R	24	3.30	1.95	0.75	3.00	0.80	17.00	35.00	4.00
4.002	GG104.VW26.098.17.49.R	26	4.90	1.95	0.70	3.95	0.80	17.00	35.00	4.00
4.001	GG104.VW28.091.17.43.R	28	4.30	1.80	0.65	3.80	0.75	17.00	35.00	4.00

Series no. **25181** **25183** **25187**

Cutting direction

Code no.	Description	P	D min	f	t max	a	E	La	Lg	D h6
		Thread/inch	mm	mm	mm	mm	mm	mm	mm	mm
4.003	GG104.VW24.106.17.33.L	24	3.30	1.95	0.75	3.00	0.80	17.00	35.00	4.00
4.002	GG104.VW26.098.17.49.L	26	4.90	1.95	0.70	3.95	0.80	17.00	35.00	4.00
4.001	GG104.VW28.091.17.43.L	28	4.30	1.80	0.65	3.80	0.75	17.00	35.00	4.00

**Round shank holder, 4 clamping surfaces**

- for inserts type 104
- with internal coolant delivery

Type GB 104

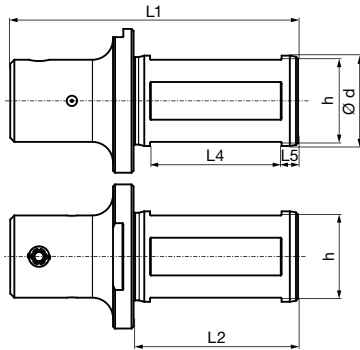
Series no. **25006**

Code no.	Description	d	d	h	L1	L2	L4	L5
		mm	inch	mm	mm	mm	mm	mm
4.010	GB104.0750.275.00.15.S.IK		3/4	17.05	69.85	40.00	32.00	4.00
4.001	GB104.0020.070.00.15.S.IK	20.00		18.00	70.00	40.00	32.00	4.00
4.002	GB104.0022.070.00.15.S.IK	22.00		20.00	70.00	40.00	32.00	4.00
4.003	GB104.0025.070.00.15.S.IK	25.00		23.00	70.00	40.00	32.00	4.00
4.011	GB104.1000.275.00.15.S.IK		1"	23.40	69.85	40.00	32.00	4.00

Spare parts

Series no.	Clamping screw	Tightening torque
25900		Nm
Code 6.000	M6x7.5x15IP	4-4.5

Series no.	Torx-Plus Wrench
25904	
Code 15.000	T15IP T-handle



Cutting insert for internal hexagon

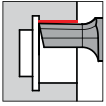

• SW 1.5-4.0

for tool holders type GB104 Art. No. 25006 see page 56

Tool material	Solid carbide		
Type	GN 104	GN 104	GN 104
Surface	S	a	○
	TiN	TiAlN-nanoA	bright

Cutting data page 148

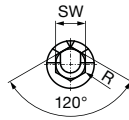
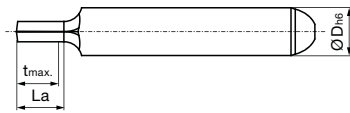
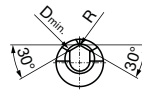
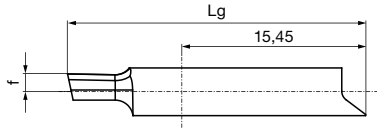

Series no. **25228** **25229** **25231**

Code no.	Description	SW	D min	R	f	t max	La	Lg	D h6
			mm	mm	mm	mm	mm	mm	mm
4.001	GN104.SW15.005.04.15.N	1.50-2.00	1.50	0.05	1.50	3.50	4.00	25.00	4.00
4.002	GN104.SW20.005.04.20.N	2.00-2.50	2.00	0.05	1.50	3.50	4.00	25.00	4.00
4.003	GN104.SW25.005.04.25.N	2.50-2.90	2.50	0.05	1.50	3.50	4.00	25.00	4.00
4.004	GN104.SW29.005.05.29.N	2.90-3.50	2.90	0.05	1.50	4.50	5.00	25.00	4.00
4.005	GN104.SW35.005.06.35.N	3.50-4.00	3.50	0.05	1.50	5.50	6.00	25.00	4.00



Cutting insert for internal square

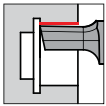

• SW 1.5-4.0

for tool holders type GB104 Art. No. 25006 see page 56

Cutting data page 148

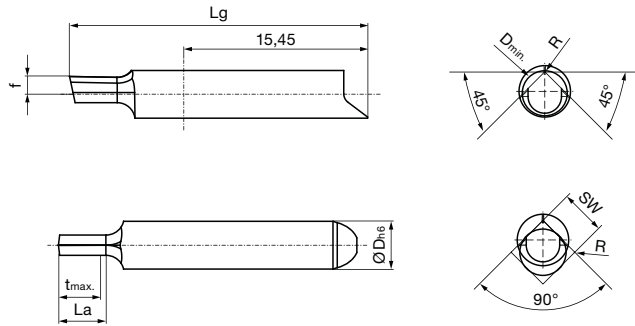

Series no. **25232** **25233** **25235**

Code no.	Description	SW	D min	R	f	t max	La	Lg	D h6
			mm	mm	mm	mm	mm	mm	mm
4.001	GN104.4545.005.04.15.N	1.50-2.00	1.50	0.05	1.50	3.50	4.00	25.00	4.00
4.002	GN104.4545.005.04.20.N	2.00-2.50	2.00	0.05	1.50	3.50	4.00	25.00	4.00
4.003	GN104.4545.005.04.25.N	2.50-2.90	2.50	0.05	1.50	3.50	4.00	25.00	4.00
4.004	GN104.4545.005.05.29.N	2.90-3.50	2.90	0.05	1.50	4.50	5.00	25.00	4.00
4.005	GN104.4545.005.06.35.N	3.50-4.00	3.50	0.05	1.50	5.50	6.00	25.00	4.00



Cutting insert for Torx

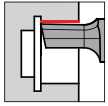

• Torx 8-30

for tool holders type GB104 Art. No. 25006 see page 56

Tool material	Solid carbide		
Type	GN 104	GN 104	GN 104
Surface	S	a	○
	TiN	TiAlN-nanoA	bright

Cutting data page 148

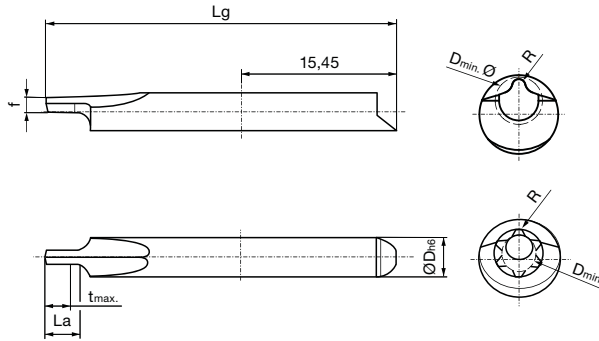

Series no. **25236** **25237** **25239**

Code no.	Description	Torx	D min	R	f	t max	La	Lg	D h6
			mm	mm	mm	mm	mm	mm	mm
4.001	GN104.TX08.024.03.17.N	T8	1.70	0.24	1.80	2.50	3.00	35.00	4.00
4.002	GN104.TX10.028.03.20.N	T10	2.00	0.28	1.80	2.50	3.00	35.00	4.00
4.003	GN104.TX15.033.04.24.N	T15	2.40	0.33	1.80	3.50	4.00	40.00	4.00
4.004	GN104.TX20.039.04.28.N	T20	2.80	0.39	1.80	3.50	4.00	40.00	4.00
4.005	GN104.TX25.045.05.32.N	T25	3.20	0.45	1.80	4.50	5.00	40.00	4.00
4.006	GN104.TX30.056.05.40.N	T30	4.00	0.56	1.80	4.50	5.00	40.00	4.00

106





SYSTEM 106

MICRO-PRECISION TOOLS

System 106



Round shank holder

from page 62



Square shank holder

from page 69



Modular holder

from page 71



Round shank holder
Broaching
page 118

Tool holder

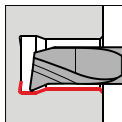

Boring out
and profiling, Type GT
from page 74

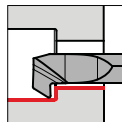

Back boring
and profiling, Type GT
page 84

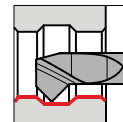

Boring out
and chamfering, Type GT
page 85

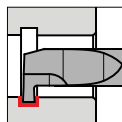

Internal grooving,
straight slots, Type GE
from page 87

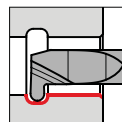

Internal grooving,
full radius slots, Type GE
from page 89

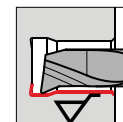

Boring out,
with Wiper, Type GJ
page 100

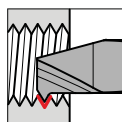

Internal threading,
Type GG
from page 113

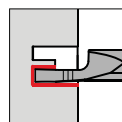

Axial grooving bores,
Type GA
from page 109

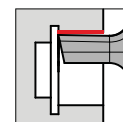

Broaching,
Type GN
page 119

Cutting inserts from hole-Ø 5 mm



Round shank holder, clamping screw top

- for inserts type 106
- with internal coolant delivery

Type GB 106

System 106

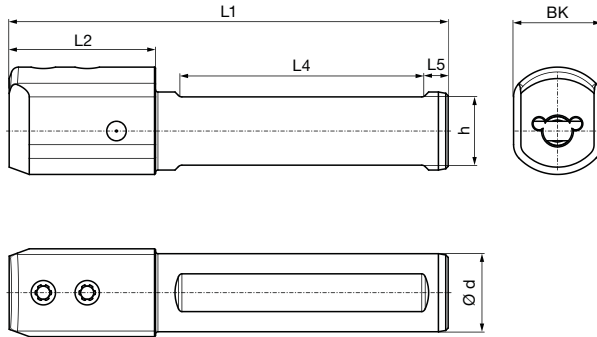

Series no. 25300

Code no.	Description	d	d	h	L1	L2	L4	L5	BK
		mm	inch	mm	mm	mm	mm	mm	mm
6.001	GB106.0010.090.00.22.N.IK	10.00		9.00	90.00	30.00	50.00	5.00	13.0
6.002	GB106.0012.090.00.22.N.IK	12.00		11.00	90.00	30.00	50.00	5.00	14.0
6.015	GB106.0500.354.00.22.N.IK		1/2	11.00	89.92	26.67	54.86	5.08	13.9
6.016	GB106.0625.354.00.22.N.IK		5/8	14.00	89.92	26.67	54.86	5.08	17.7
6.003	GB106.0016.090.00.22.N.IK	16.00		14.00	90.00	30.00	50.00	5.00	18.0
6.017	GB106.0750.415.00.22.N.IK		3/4	17.04	105.41	26.67	69.85	5.08	
6.004	GB106.0020.095.00.22.N.IK	20.00		18.00	95.00	30.00	55.00	5.00	
6.005	GB106.0022.095.00.22.N.IK	22.00		20.00	95.00		55.00	5.00	
6.006	GB106.0025.100.00.22.N.IK	25.00		23.00	100.00		55.00	5.00	
6.018	GB106.1000.415.00.22.N.IK		1"	23.39	105.41		69.85	5.08	

Spare parts

Series no.	Clamping screw	Tightening torque
25900		Nm
Code 6.000	M6x7.5x15IP	4-4.5

Series no.	Torx-Plus Wrench
25904	
Code 15.000	T15IP T-handle



Round shank holder, clamping screw lateral

- for inserts type 106
- with internal coolant delivery

Type GB 106

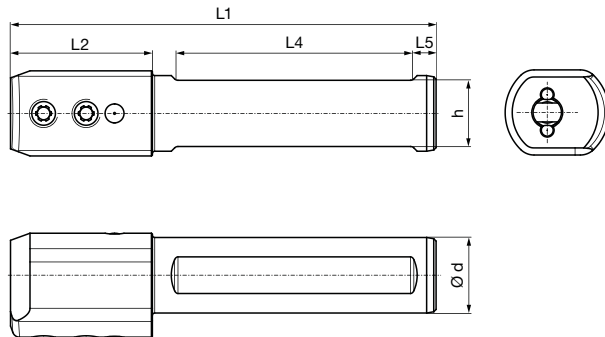

System 106

Series no. 25301

Code no.	Description	d	d	h	L1	L2	L4	L5
		mm	inch	mm	mm	mm	mm	mm
6.001	GB106.0010.090.00.22.N.IK.90	10.00		9.00	90.00	30.00	50.00	5.00
6.002	GB106.0012.090.00.22.N.IK.90	12.00		11.00	90.00	30.00	50.00	5.00
6.015	GB106.0500.354.00.22.N.IK.90		1/2	11.00	89.92	26.67	54.86	5.08
6.016	GB106.0625.354.00.22.N.IK.90		5/8	14.00	89.92	26.67	54.86	5.08
6.003	GB106.0016.090.00.22.N.IK.90	16.00		14.00	90.00	30.00	50.00	5.00
6.017	GB106.0750.415.00.22.N.IK.90		3/4	17.04	105.41	26.67	69.85	5.08
6.004	GB106.0020.095.00.22.N.IK.90	20.00		18.00	95.00	30.00	55.00	5.00
6.005	GB106.0022.095.00.22.N.IK.90	22.00		20.00	95.00		55.00	5.00
6.006	GB106.0025.100.00.22.N.IK.90	25.00		23.00	100.00		55.00	5.00
6.018	GB106.1000.415.00.22.N.IK.90		1"	23.39	105.41		69.85	5.08

Spare parts

Series no.	Clamping screw	Tightening torque
25900		Nm
Code 6.000	M6x7.5x15IP	4-4.5

Series no.	Torx-Plus Wrench
25904	
Code 15.000	T15IP T-handle



Round shank holder, clamping screw above, four clamping surfaces

- for inserts type 106
- with internal coolant delivery

Type GB 106

System 106

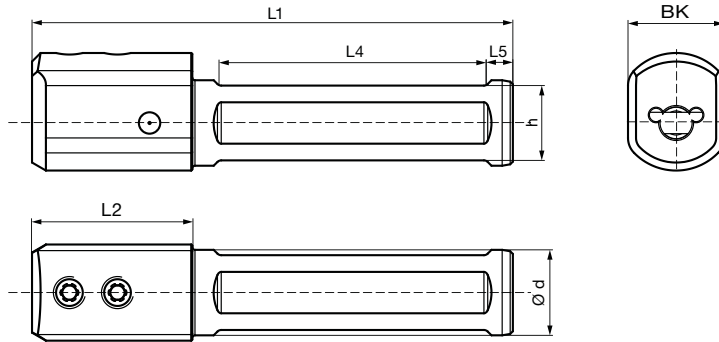

Series no. **25320**

version left and right

Code no.	Description	d	h	L1	L2	L4	L5	BK
		mm	mm	mm	mm	mm	mm	mm
6.010	GB106.0016.090.00.22.N.IK.VSP	16.00	14.00	90.00	30.00	50.00	5.00	18.0
6.020	GB106.0020.095.00.22.N.IK.VSP	20.00	18.00	95.00	30.00	55.00	5.00	
6.030	GB106.0022.095.00.22.N.IK.VSP	22.00	20.00	95.00		55.00	5.00	
6.040	GB106.0025.100.00.22.N.IK.VSP	25.00	23.00	100.00		55.00	5.00	

Spare parts

Series no.	Clamping screw	Tightening torque
25900		Nm
Code 6.000	M6x7.5x15IP	4-4.5

Series no.	Torx-Plus Wrench
25904	
Code 15.000	T15IP T-handle



Round shank holder, clamping screw above, without clamping surfaces

- for inserts type 106
- with internal coolant delivery

Type	GB 106
------	--------

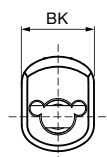
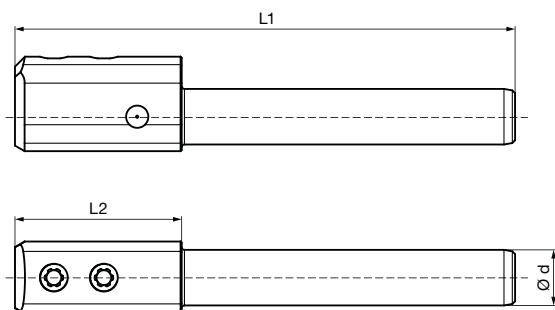

System 106

Series no. **25319**
version left and right

Code no.	Description	d	L1	L2	BK
		mm	mm	mm	mm
6.010	GB106.0010.090.00.22.N.IK.RND	10.00	90.00	30.00	13.0
6.020	GB106.0012.090.00.22.N.IK.RND	12.00	90.00	30.00	14.0
6.030	GB106.0016.090.00.22.N.IK.RND	16.00	90.00	30.00	18.0

Spare parts

Series no.	Clamping screw	Tightening torque
		Nm
25900		
Code 6.000	M6x7.5x15IP	4-4.5

Series no.	Torx-Plus Wrench
25904	
Code 15.000	T15IP T-handle



Round shank holder, clamping screw above, for Citizen machine

- for inserts type 106
- with internal coolant delivery

Type GB 106

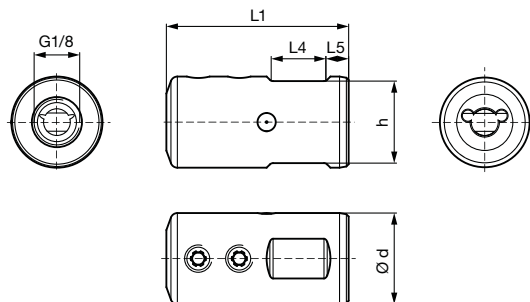

Series no. **25316**

version left and right

Code no.	Description	d		h	L1	L4	L5
		mm	inch				
6.110	GB106.0750.040.00.22.N.IK.CIT		3/4	17.05	40.00	12.70	5.08
6.120	GB106.0750.050.00.22.N.IK.CIT		3/4	17.05	50.00	22.86	5.08
6.130	GB106.0750.070.00.22.N.IK.CIT		3/4	17.05	70.00	44.45	5.08
6.140	GB106.0750.100.00.22.N.IK.CIT		3/4	17.05	100.00	73.66	5.08
6.010	GB106.0020.040.00.22.N.IK.CIT	20.00		18.00	40.00	12.00	5.00
6.020	GB106.0020.050.00.22.N.IK.CIT	20.00		18.00	50.00	22.00	5.00
6.150	GB106.1000.060.00.22.N.IK.CIT		1"	23.40	60.00	31.75	5.08
6.160	GB106.1000.100.00.22.N.IK.CIT		1"	23.40	100.00	73.66	5.08

Spare parts

Series no.	Clamping screw	Tightening torque
25900		Nm
Code 6.000	M6x7.5x15IP	4-4.5

Series no.	Torx-Plus Wrench
25904	
Code 15.000	T15IP T-handle



Round shank holder, clamping screw above, for Star machine

- for inserts type 106
- with internal coolant delivery

Type GB 106

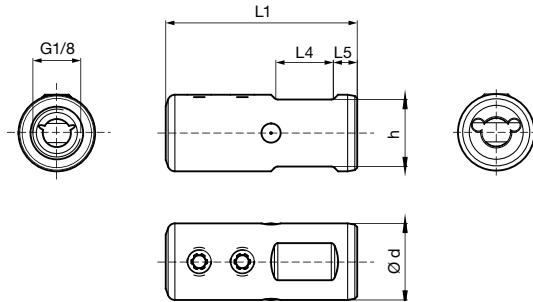

Series no. **25317**
version left and right

Code no.	Description	d	h	L1	L4	L5
		mm	mm	mm	mm	mm
6.010	GB106.0016.040.00.22.N.IK.STA	16.00	14.00	40.00	12.00	5.00
6.020	GB106.0016.050.00.22.N.IK.STA	16.00	14.00	50.00	22.00	5.00
6.030	GB106.0016.070.00.22.N.IK.STA	16.00	14.00	70.00	42.00	5.00
6.040	GB106.0022.038.00.22.N.IK.STA	22.00	20.00	38.00	10.00	5.00
6.050	GB106.0022.050.00.22.N.IK.STA	22.00	20.00	50.00	20.00	5.00
6.060	GB106.0022.070.00.22.N.IK.STA	22.00	20.00	70.00	40.00	5.00
6.070	GB106.0022.100.00.22.N.IK.STA	22.00	20.00	100.00	70.00	5.00
6.080	GB106.0022.120.00.22.N.IK.STA	22.00	20.00	120.00	90.00	5.00

Spare parts

Series no.	Clamping screw	Tightening torque
25900		Nm
Code 6.000	M6x7.5x15IP	4-4.5

Series no.	Torx-Plus Wrench
25904	
Code 15.000	T15IP T-handle



Round shank holder, clamping screw above, for Tornos machine

- for inserts type 106
- with internal coolant delivery

Type GB 106

System 106

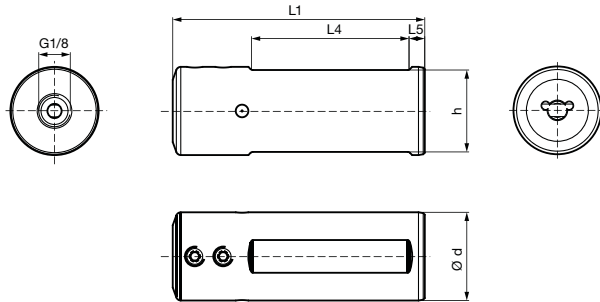

Series no. **25318**
version left and right

Code no.	Description	d	h	L1	L4	L5
		mm	mm	mm	mm	mm
6.010	GB106.0018.310.00.22.N.IK.TOR	18.00	16.00	310.00	280.00	5.00
6.020	GB106.0020.170.00.22.N.IK.TOR	20.00	18.00	170.00	140.00	5.00
6.030	GB106.0020.185.00.22.N.IK.TOR	20.00	18.00	185.00	155.00	5.00
6.040	GB106.0025.100.00.22.N.IK.TOR	25.00	23.00	100.00	70.00	5.00
6.050	GB106.0025.150.00.22.N.IK.TOR	25.00	23.00	150.00	120.00	5.00
6.060	GB106.0028.080.00.22.N.IK.TOR	28.00	26.00	80.00	50.00	5.00

Spare parts

Series no.	Clamping screw	Tightening torque
25900		Nm
Code 6.000	M6x7.5x15IP	4-4.5

Series no.	Torx-Plus Wrench
25904	
Code 15.000	T15IP T-handle



Square shank holder, straight 0°

- for inserts type 106
- without internal coolant delivery

Type GH 106

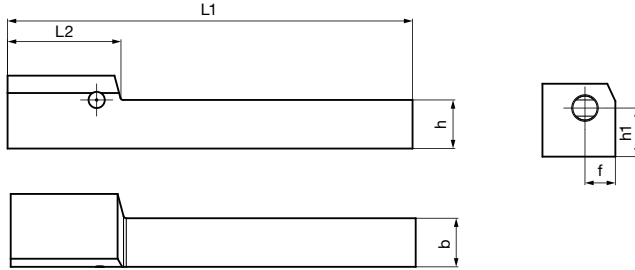

Right hand version shown
Left hand version mirror image

Series no. **25314**

version right-hand

Code no.	Description	b	b	h	h1	f	L1	L2
		mm	inch	mm	mm	mm	mm	mm
6.110	GH106.0375.350.00.22.R		3/8	9.52	9.52	7.62	88.90	27.94
6.010	GH106.1010.100.00.22.R	10.00		10.00	10.00	7.50	100.00	28.00
6.020	GH106.1212.100.00.22.R	12.00		12.00	12.00	7.50	100.00	28.00
6.120	GH106.0500.350.00.22.R		1/2	12.70	12.70	7.62	88.90	27.94
6.130	GH106.0625.400.00.22.R		5/8	15.87	15.87	7.62	101.60	27.94
6.030	GH106.1616.120.00.22.R	16.00		16.00	16.00	7.50	120.00	28.00

Series no. **25315**

version left-hand

Code no.	Description	b	b	h	h1	f	L1	L2
		mm	inch	mm	mm	mm	mm	mm
6.110	GH106.0375.350.00.22.L		3/8	9.52	9.52	7.62	88.90	27.94
6.010	GH106.1010.100.00.22.L	10.00		10.00	10.00	7.50	100.00	28.00
6.020	GH106.1212.100.00.22.L	12.00		12.00	12.00	7.50	100.00	28.00
6.120	GH106.0500.350.00.22.L		1/2	12.70	12.70	7.62	88.90	27.94
6.130	GH106.0625.400.00.22.L		5/8	15.87	15.87	7.62	101.60	27.94
6.030	GH106.1616.120.00.22.L	16.00		16.00	16.00	7.50	120.00	28.00

Spare parts

Series no.	Clamping screw	Tightening torque
25900		Nm
Code 6.000	M6x7.5x15IP	4-4.5

Series no.	Torx-Plus Wrench
25904	
Code 15.000	T15IP T-handle

System 106



Square shank holder, 90° offset

- for inserts type 106
- without internal coolant delivery

Type GH 106

System 106

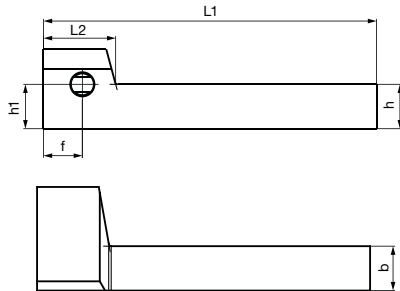

Right hand version shown
Left hand version mirror image

Series no. **25304**
version right-hand

Code no.	Description	b mm	b inch	h mm	h1 mm	f mm	L1 mm	L2 mm
6.010	GH106.0375.350.90.22.R		3/8	9.52	9.52	22.00	88.90	19.50
6.001	GH106.1010.090.90.22.R	10.00		10.00	10.00	22.00	90.00	19.50
6.002	GH106.1212.090.90.22.R	12.00		12.00	12.00	22.00	90.00	19.50
6.011	GH106.0500.350.90.22.R		1/2	12.70	12.70	22.00	88.90	19.50
6.012	GH106.0625.400.90.22.R		5/8	15.87	15.87	22.00	101.60	19.50
6.003	GH106.1616.120.90.22.R	16.00		16.00	16.00	22.00	120.00	19.50

Series no. **25305**
version left-hand

Code no.	Description	b mm	b inch	h mm	h1 mm	f mm	L1 mm	L2 mm
6.010	GH106.0375.350.90.22.L		3/8	9.52	9.52	22.00	88.90	19.50
6.001	GH106.1010.090.90.22.L	10.00		10.00	10.00	22.00	90.00	19.50
6.002	GH106.1212.090.90.22.L	12.00		12.00	12.00	22.00	90.00	19.50
6.011	GH106.0500.350.90.22.L		1/2	12.70	12.70	22.00	88.90	19.50
6.012	GH106.0625.400.90.22.L		5/8	15.87	15.87	22.00	101.60	19.50
6.003	GH106.1616.120.90.22.L	16.00		16.00	16.00	22.00	120.00	19.50

Spare parts

Series no.	Clamping screw	Tightening torque Nm
25900		
Code 6.000	M6x7.5x15IP	4-4.5

Series no.	Torx-Plus Wrench
25904	
Code 15.000	T15IP T-handle



Polygon shank holder, to ISO 26623, straight 0°

- for inserts type 106
- with internal coolant delivery

Type GH 106

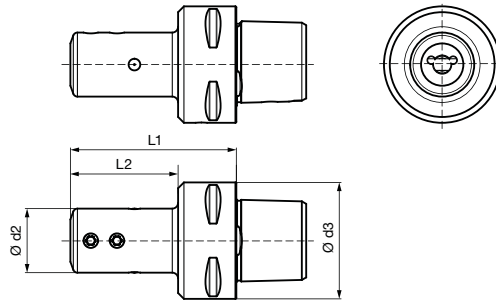

Series no. **25307**

version left and right

Code no.	Description	d2	d3	L1	L2
		mm		mm	mm
6.001	GH106.PO32.052.00.22.N.IK	22.00	PSC 32	52.00	37.00
6.002	GH106.PO40.057.00.22.N.IK	22.00	PSC 40	57.00	37.00
6.003	GH106.PO50.057.00.22.N.IK	22.00	PSC 50	57.00	37.00
6.004	GH106.PO63.060.00.22.N.IK	22.00	PSC 63	60.00	38.00

Spare parts

Series no.	Clamping screw	Tightening torque
25900		Nm
Code 6.000	M6x7.5x15IP	4-4.5

Series no.	Torx-Plus Wrench
25904	
Code 15.000	T15IP T-handle

System 106



Polygon shank holder, to ISO 26623, off-set 90°

- for inserts type 106
- with internal coolant delivery

Type GH 106

System 106

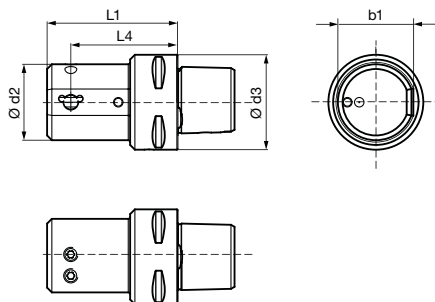

Right hand version shown
Left hand version mirror image

Series no. **25308**

version right-hand

Code no.	Description	d2	d3	L1	L4	b1
		mm		mm	mm	mm
6.001	GH106.PO32.045.90.22.R.IK	32.00	PSC 32	55.00	45.00	31.00
6.002	GH106.PO40.045.90.22.R.IK	32.00	PSC 40	55.00	45.00	31.00
6.003	GH106.PO50.050.90.22.R.IK	32.00	PSC 50	60.00	50.00	31.00
6.004	GH106.PO63.050.90.22.R.IK	32.00	PSC 63	60.00	50.00	31.00

Series no. **25309**

version left-hand

Code no.	Description	d2	d3	L1	L4	b1
		mm		mm	mm	mm
6.001	GH106.PO32.045.90.22.L.IK	32.00	PSC 32	55.00	45.00	31.00
6.002	GH106.PO40.045.90.22.L.IK	32.00	PSC 40	55.00	45.00	31.00
6.003	GH106.PO50.050.90.22.L.IK	32.00	PSC 50	60.00	50.00	31.00
6.004	GH106.PO63.050.90.22.L.IK	32.00	PSC 63	60.00	50.00	31.00

Spare parts

Series no.	Clamping screw	Tightening torque
25900		Nm
Code 6.000	M6x7.5x15IP	4-4.5

Series no.	Torx-Plus Wrench
25904	
Code 15.000	T15IP T-handle



HSK-T holder, to ISO 12164-3, straight 0°

- for inserts type 106
- with internal coolant delivery

Type GH 106

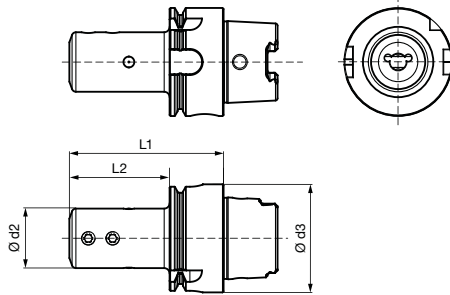

System 106

Series no. **25311**

version left and right

Code no.	Description	d2	d3	L1	L2
		mm		mm	mm
6.001	GH106.HS40.057.00.22.N.IK	22.00	HSK-T 40	57.00	37.00
6.002	GH106.HS63.063.00.22.N.IK	22.00	HSK-T 63	63.00	37.00

Spare parts

Series no.	Clamping screw	Tightening torque
		Nm
25900		
Code 6.000	M6x7.5x15IP	4-4.5

Series no.	Torx-Plus Wrench
25904	
Code 15.000	T15IP T-handle



Cutting insert for boring out and profiling

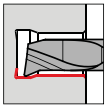

• radial free 23°

for tool holders type GB106 see from page 62

Cutting data page 148

System 106

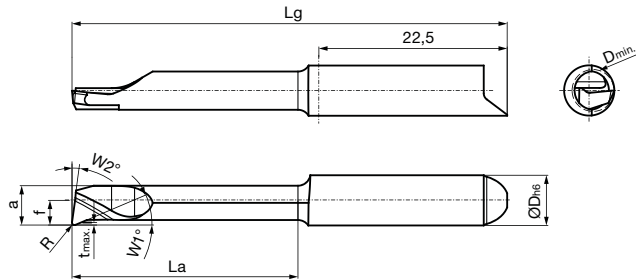

Right hand version shown
Left hand version mirror image

Tool material	Solid carbide			
	Type	GT 106	GT 106	GT 106
Surface	S	a	○	
	TiN	nano-A	bright	





Series no.	25832	25834	25838
Cutting direction	(R)	(R)	(R)

Code no.	Description	D min	R	W1	W2	f	a	t max	La	Lg	D h6
		mm	mm	°	°	mm	mm	mm	mm	mm	mm
6.010	GT106.2347.005.12.50.R	5.00	0.05	23	8	2.95	4.70	0.30	12.00	37.00	6.00
6.020	GT106.2347.005.17.50.R	5.00	0.05	23	8	2.95	4.70	0.30	17.00	42.00	6.00
6.030	GT106.2347.005.22.50.R	5.00	0.05	23	8	2.95	4.70	0.30	22.00	47.00	6.00
6.040	GT106.2347.005.27.50.R	5.00	0.05	23	8	2.95	4.70	0.30	27.00	52.00	6.00
6.050	GT106.2347.005.32.50.R	5.00	0.05	23	8	2.95	4.70	0.30	32.00	57.00	6.00
6.060	GT106.2347.005.37.50.R	5.00	0.05	23	8	2.95	4.70	0.30	37.00	62.00	6.00
6.070	GT106.2347.005.42.50.R	5.00	0.05	23	8	2.95	4.70	0.30	42.00	67.00	6.00
6.110	GT106.2347.010.12.50.R	5.00	0.10	23	8	2.95	4.70	0.30	12.00	37.00	6.00
6.120	GT106.2347.010.17.50.R	5.00	0.10	23	8	2.95	4.70	0.30	17.00	42.00	6.00
6.130	GT106.2347.010.22.50.R	5.00	0.10	23	8	2.95	4.70	0.30	22.00	47.00	6.00
6.140	GT106.2347.010.27.50.R	5.00	0.10	23	8	2.95	4.70	0.30	27.00	52.00	6.00
6.150	GT106.2347.010.32.50.R	5.00	0.10	23	8	2.95	4.70	0.30	32.00	57.00	6.00
6.160	GT106.2347.010.37.50.R	5.00	0.10	23	8	2.95	4.70	0.30	37.00	62.00	6.00
6.170	GT106.2347.010.42.50.R	5.00	0.10	23	8	2.95	4.70	0.30	42.00	67.00	6.00
6.210	GT106.2347.015.12.50.R	5.00	0.15	23	8	2.95	4.70	0.30	12.00	37.00	6.00
6.220	GT106.2347.015.17.50.R	5.00	0.15	23	8	2.95	4.70	0.30	17.00	42.00	6.00
6.230	GT106.2347.015.22.50.R	5.00	0.15	23	8	2.95	4.70	0.30	22.00	47.00	6.00
6.240	GT106.2347.015.27.50.R	5.00	0.15	23	8	2.95	4.70	0.30	27.00	52.00	6.00
6.250	GT106.2347.015.32.50.R	5.00	0.15	23	8	2.95	4.70	0.30	32.00	57.00	6.00
6.260	GT106.2347.015.37.50.R	5.00	0.15	23	8	2.95	4.70	0.30	37.00	62.00	6.00
6.270	GT106.2347.015.42.50.R	5.00	0.15	23	8	2.95	4.70	0.30	42.00	67.00	6.00
6.310	GT106.2347.020.12.50.R	5.00	0.20	23	8	2.95	4.70	0.30	12.00	37.00	6.00
6.320	GT106.2347.020.17.50.R	5.00	0.20	23	8	2.95	4.70	0.30	17.00	42.00	6.00
6.330	GT106.2347.020.22.50.R	5.00	0.20	23	8	2.95	4.70	0.30	22.00	47.00	6.00
6.340	GT106.2347.020.27.50.R	5.00	0.20	23	8	2.95	4.70	0.30	27.00	52.00	6.00
6.350	GT106.2347.020.32.50.R	5.00	0.20	23	8	2.95	4.70	0.30	32.00	57.00	6.00
6.360	GT106.2347.020.37.50.R	5.00	0.20	23	8	2.95	4.70	0.30	37.00	62.00	6.00
6.370	GT106.2347.020.42.50.R	5.00	0.20	23	8	2.95	4.70	0.30	42.00	67.00	6.00
6.410	GT106.2347.030.12.50.R	5.00	0.30	23	8	2.95	4.70	0.30	12.00	37.00	6.00
6.420	GT106.2347.030.17.50.R	5.00	0.30	23	8	2.95	4.70	0.30	17.00	42.00	6.00
6.430	GT106.2347.030.22.50.R	5.00	0.30	23	8	2.95	4.70	0.30	22.00	47.00	6.00
6.440	GT106.2347.030.27.50.R	5.00	0.30	23	8	2.95	4.70	0.30	27.00	52.00	6.00
6.450	GT106.2347.030.32.50.R	5.00	0.30	23	8	2.95	4.70	0.30	32.00	57.00	6.00
6.460	GT106.2347.030.37.50.R	5.00	0.30	23	8	2.95	4.70	0.30	37.00	62.00	6.00
6.470	GT106.2347.030.42.50.R	5.00	0.30	23	8	2.95	4.70	0.30	42.00	67.00	6.00



Series no. **25833** **25835** **25839**

Cutting direction   

Code no.	Description	D min	R	W1	W2	f	a	t max	La	Lg	D h6
		mm	mm	°	°	mm	mm	mm	mm	mm	mm
6.010	GT106.2347.005.12.50.L	5.00	0.05	23	8	2.95	4.70	0.30	12.00	37.00	6.00
6.020	GT106.2347.005.17.50.L	5.00	0.05	23	8	2.95	4.70	0.30	17.00	42.00	6.00
6.030	GT106.2347.005.22.50.L	5.00	0.05	23	8	2.95	4.70	0.30	22.00	47.00	6.00
6.040	GT106.2347.005.27.50.L	5.00	0.05	23	8	2.95	4.70	0.30	27.00	52.00	6.00
6.050	GT106.2347.005.32.50.L	5.00	0.05	23	8	2.95	4.70	0.30	32.00	57.00	6.00
6.060	GT106.2347.005.37.50.L	5.00	0.05	23	8	2.95	4.70	0.30	37.00	62.00	6.00
6.070	GT106.2347.005.42.50.L	5.00	0.05	23	8	2.95	4.70	0.30	42.00	67.00	6.00
6.110	GT106.2347.010.12.50.L	5.00	0.10	23	8	2.95	4.70	0.30	12.00	37.00	6.00
6.120	GT106.2347.010.17.50.L	5.00	0.10	23	8	2.95	4.70	0.30	17.00	42.00	6.00
6.130	GT106.2347.010.22.50.L	5.00	0.10	23	8	2.95	4.70	0.30	22.00	47.00	6.00
6.140	GT106.2347.010.27.50.L	5.00	0.10	23	8	2.95	4.70	0.30	27.00	52.00	6.00
6.150	GT106.2347.010.32.50.L	5.00	0.10	23	8	2.95	4.70	0.30	32.00	57.00	6.00
6.160	GT106.2347.010.37.50.L	5.00	0.10	23	8	2.95	4.70	0.30	37.00	62.00	6.00
6.170	GT106.2347.010.42.50.L	5.00	0.10	23	8	2.95	4.70	0.30	42.00	67.00	6.00
6.210	GT106.2347.015.12.50.L	5.00	0.15	23	8	2.95	4.70	0.30	12.00	37.00	6.00
6.220	GT106.2347.015.17.50.L	5.00	0.15	23	8	2.95	4.70	0.30	17.00	42.00	6.00
6.230	GT106.2347.015.22.50.L	5.00	0.15	23	8	2.95	4.70	0.30	22.00	47.00	6.00
6.240	GT106.2347.015.27.50.L	5.00	0.15	23	8	2.95	4.70	0.30	27.00	52.00	6.00
6.250	GT106.2347.015.32.50.L	5.00	0.15	23	8	2.95	4.70	0.30	32.00	57.00	6.00
6.260	GT106.2347.015.37.50.L	5.00	0.15	23	8	2.95	4.70	0.30	37.00	62.00	6.00
6.270	GT106.2347.015.42.50.L	5.00	0.15	23	8	2.95	4.70	0.30	42.00	67.00	6.00
6.310	GT106.2347.020.12.50.L	5.00	0.20	23	8	2.95	4.70	0.30	12.00	37.00	6.00
6.320	GT106.2347.020.17.50.L	5.00	0.20	23	8	2.95	4.70	0.30	17.00	42.00	6.00
6.330	GT106.2347.020.22.50.L	5.00	0.20	23	8	2.95	4.70	0.30	22.00	47.00	6.00
6.340	GT106.2347.020.27.50.L	5.00	0.20	23	8	2.95	4.70	0.30	27.00	52.00	6.00
6.350	GT106.2347.020.32.50.L	5.00	0.20	23	8	2.95	4.70	0.30	32.00	57.00	6.00
6.360	GT106.2347.020.37.50.L	5.00	0.20	23	8	2.95	4.70	0.30	37.00	62.00	6.00
6.370	GT106.2347.020.42.50.L	5.00	0.20	23	8	2.95	4.70	0.30	42.00	67.00	6.00
6.410	GT106.2347.030.12.50.L	5.00	0.30	23	8	2.95	4.70	0.30	12.00	37.00	6.00
6.420	GT106.2347.030.17.50.L	5.00	0.30	23	8	2.95	4.70	0.30	17.00	42.00	6.00
6.430	GT106.2347.030.22.50.L	5.00	0.30	23	8	2.95	4.70	0.30	22.00	47.00	6.00
6.440	GT106.2347.030.27.50.L	5.00	0.30	23	8	2.95	4.70	0.30	27.00	52.00	6.00
6.450	GT106.2347.030.32.50.L	5.00	0.30	23	8	2.95	4.70	0.30	32.00	57.00	6.00
6.460	GT106.2347.030.37.50.L	5.00	0.30	23	8	2.95	4.70	0.30	37.00	62.00	6.00
6.470	GT106.2347.030.42.50.L	5.00	0.30	23	8	2.95	4.70	0.30	42.00	67.00	6.00

System 106



Cutting insert for boring out and profiling

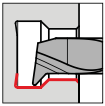

• radial free 47°, tmax 0.6

for tool holders type GB106 see from page 62

Tool material	Solid carbide			
	Type	GT 106	GT 106	GT 106
Surface	S	a	○	
	TiN	nano-A	bright	

Cutting data page 148

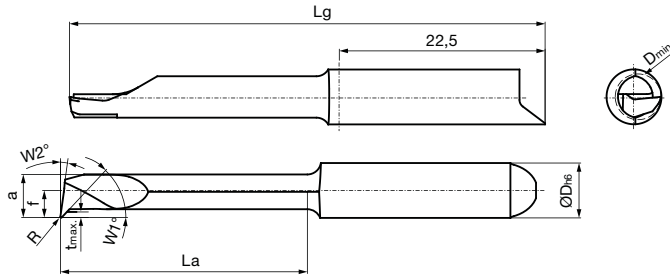

Right hand version shown
Left hand version mirror image

Series no.	25840	25842	25846
Cutting direction	(R)	(R)	(R)

Code no.	Description	D min	R	W1	W2	f	a	t max	La	Lg	D h6
		mm	mm	°	°	mm	mm	mm	mm	mm	mm
6.010	GT106.4747.005.12.50.R	5.00	0.05	47	8	2.95	4.70	0.60	12.00	37.00	6.00
6.020	GT106.4747.005.17.50.R	5.00	0.05	47	8	2.95	4.70	0.60	17.00	42.00	6.00
6.030	GT106.4747.005.22.50.R	5.00	0.05	47	8	2.95	4.70	0.60	22.00	47.00	6.00
6.040	GT106.4747.005.27.50.R	5.00	0.05	47	8	2.95	4.70	0.60	27.00	52.00	6.00
6.050	GT106.4747.005.32.50.R	5.00	0.05	47	8	2.95	4.70	0.60	32.00	57.00	6.00
6.060	GT106.4747.005.37.50.R	5.00	0.05	47	8	2.95	4.70	0.60	37.00	62.00	6.00
6.070	GT106.4747.005.42.50.R	5.00	0.05	47	8	2.95	4.70	0.60	42.00	67.00	6.00
6.110	GT106.4747.010.12.50.R	5.00	0.10	47	8	2.95	4.70	0.60	12.00	37.00	6.00
6.120	GT106.4747.010.17.50.R	5.00	0.10	47	8	2.95	4.70	0.60	17.00	42.00	6.00
6.130	GT106.4747.010.22.50.R	5.00	0.10	47	8	2.95	4.70	0.60	22.00	47.00	6.00
6.140	GT106.4747.010.27.50.R	5.00	0.10	47	8	2.95	4.70	0.60	27.00	52.00	6.00
6.150	GT106.4747.010.32.50.R	5.00	0.10	47	8	2.95	4.70	0.60	32.00	57.00	6.00
6.160	GT106.4747.010.37.50.R	5.00	0.10	47	8	2.95	4.70	0.60	37.00	62.00	6.00
6.170	GT106.4747.010.42.50.R	5.00	0.10	47	8	2.95	4.70	0.60	42.00	67.00	6.00
6.210	GT106.4747.015.12.50.R	5.00	0.15	47	8	2.95	4.70	0.60	12.00	37.00	6.00
6.220	GT106.4747.015.17.50.R	5.00	0.15	47	8	2.95	4.70	0.60	17.00	42.00	6.00
6.230	GT106.4747.015.22.50.R	5.00	0.15	47	8	2.95	4.70	0.60	22.00	47.00	6.00
6.240	GT106.4747.015.27.50.R	5.00	0.15	47	8	2.95	4.70	0.60	27.00	52.00	6.00
6.250	GT106.4747.015.32.50.R	5.00	0.15	47	8	2.95	4.70	0.60	32.00	57.00	6.00
6.260	GT106.4747.015.37.50.R	5.00	0.15	47	8	2.95	4.70	0.60	37.00	62.00	6.00
6.270	GT106.4747.015.42.50.R	5.00	0.15	47	8	2.95	4.70	0.60	42.00	67.00	6.00
6.310	GT106.4747.020.12.50.R	5.00	0.20	47	8	2.95	4.70	0.60	12.00	37.00	6.00
6.320	GT106.4747.020.17.50.R	5.00	0.20	47	8	2.95	4.70	0.60	17.00	42.00	6.00
6.330	GT106.4747.020.22.50.R	5.00	0.20	47	8	2.95	4.70	0.60	22.00	47.00	6.00
6.340	GT106.4747.020.27.50.R	5.00	0.20	47	8	2.95	4.70	0.60	27.00	52.00	6.00
6.350	GT106.4747.020.32.50.R	5.00	0.20	47	8	2.95	4.70	0.60	32.00	57.00	6.00
6.360	GT106.4747.020.37.50.R	5.00	0.20	47	8	2.95	4.70	0.60	37.00	62.00	6.00
6.370	GT106.4747.020.42.50.R	5.00	0.20	47	8	2.95	4.70	0.60	42.00	67.00	6.00
6.410	GT106.4747.030.12.50.R	5.00	0.30	47	8	2.95	4.70	0.60	12.00	37.00	6.00
6.420	GT106.4747.030.17.50.R	5.00	0.30	47	8	2.95	4.70	0.60	17.00	42.00	6.00
6.430	GT106.4747.030.22.50.R	5.00	0.30	47	8	2.95	4.70	0.60	22.00	47.00	6.00
6.440	GT106.4747.030.27.50.R	5.00	0.30	47	8	2.95	4.70	0.60	27.00	52.00	6.00
6.450	GT106.4747.030.32.50.R	5.00	0.30	47	8	2.95	4.70	0.60	32.00	57.00	6.00
6.460	GT106.4747.030.37.50.R	5.00	0.30	47	8	2.95	4.70	0.60	37.00	62.00	6.00
6.470	GT106.4747.030.42.50.R	5.00	0.30	47	8	2.95	4.70	0.60	42.00	67.00	6.00

Series no. **25841** **25843** **25847**Cutting direction   

Code no.	Description	D min	R	W1	W2	f	a	t max	La	Lg	D h6
		mm	mm	°	°	mm	mm	mm	mm	mm	mm
6.010	GT106.4747.005.12.50.L	5.00	0.05	47	8	2.95	4.70	0.60	12.00	37.00	6.00
6.020	GT106.4747.005.17.50.L	5.00	0.05	47	8	2.95	4.70	0.60	17.00	42.00	6.00
6.030	GT106.4747.005.22.50.L	5.00	0.05	47	8	2.95	4.70	0.60	22.00	47.00	6.00
6.040	GT106.4747.005.27.50.L	5.00	0.05	47	8	2.95	4.70	0.60	27.00	52.00	6.00
6.050	GT106.4747.005.32.50.L	5.00	0.05	47	8	2.95	4.70	0.60	32.00	57.00	6.00
6.060	GT106.4747.005.37.50.L	5.00	0.05	47	8	2.95	4.70	0.60	37.00	62.00	6.00
6.070	GT106.4747.005.42.50.L	5.00	0.05	47	8	2.95	4.70	0.60	42.00	67.00	6.00
6.110	GT106.4747.010.12.50.L	5.00	0.10	47	8	2.95	4.70	0.60	12.00	37.00	6.00
6.120	GT106.4747.010.17.50.L	5.00	0.10	47	8	2.95	4.70	0.60	17.00	42.00	6.00
6.130	GT106.4747.010.22.50.L	5.00	0.10	47	8	2.95	4.70	0.60	22.00	47.00	6.00
6.140	GT106.4747.010.27.50.L	5.00	0.10	47	8	2.95	4.70	0.60	27.00	52.00	6.00
6.150	GT106.4747.010.32.50.L	5.00	0.10	47	8	2.95	4.70	0.60	32.00	57.00	6.00
6.160	GT106.4747.010.37.50.L	5.00	0.10	47	8	2.95	4.70	0.60	37.00	62.00	6.00
6.170	GT106.4747.010.42.50.L	5.00	0.10	47	8	2.95	4.70	0.60	42.00	67.00	6.00
6.210	GT106.4747.015.12.50.L	5.00	0.15	47	8	2.95	4.70	0.60	12.00	37.00	6.00
6.220	GT106.4747.015.17.50.L	5.00	0.15	47	8	2.95	4.70	0.60	17.00	42.00	6.00
6.230	GT106.4747.015.22.50.L	5.00	0.15	47	8	2.95	4.70	0.60	22.00	47.00	6.00
6.240	GT106.4747.015.27.50.L	5.00	0.15	47	8	2.95	4.70	0.60	27.00	52.00	6.00
6.250	GT106.4747.015.32.50.L	5.00	0.15	47	8	2.95	4.70	0.60	32.00	57.00	6.00
6.260	GT106.4747.015.37.50.L	5.00	0.15	47	8	2.95	4.70	0.60	37.00	62.00	6.00
6.270	GT106.4747.015.42.50.L	5.00	0.15	47	8	2.95	4.70	0.60	42.00	67.00	6.00
6.310	GT106.4747.020.12.50.L	5.00	0.20	47	8	2.95	4.70	0.60	12.00	37.00	6.00
6.320	GT106.4747.020.17.50.L	5.00	0.20	47	8	2.95	4.70	0.60	17.00	42.00	6.00
6.330	GT106.4747.020.22.50.L	5.00	0.20	47	8	2.95	4.70	0.60	22.00	47.00	6.00
6.340	GT106.4747.020.27.50.L	5.00	0.20	47	8	2.95	4.70	0.60	27.00	52.00	6.00
6.350	GT106.4747.020.32.50.L	5.00	0.20	47	8	2.95	4.70	0.60	32.00	57.00	6.00
6.360	GT106.4747.020.37.50.L	5.00	0.20	47	8	2.95	4.70	0.60	37.00	62.00	6.00
6.370	GT106.4747.020.42.50.L	5.00	0.20	47	8	2.95	4.70	0.60	42.00	67.00	6.00
6.410	GT106.4747.030.12.50.L	5.00	0.30	47	8	2.95	4.70	0.60	12.00	37.00	6.00
6.420	GT106.4747.030.17.50.L	5.00	0.30	47	8	2.95	4.70	0.60	17.00	42.00	6.00
6.430	GT106.4747.030.22.50.L	5.00	0.30	47	8	2.95	4.70	0.60	22.00	47.00	6.00
6.440	GT106.4747.030.27.50.L	5.00	0.30	47	8	2.95	4.70	0.60	27.00	52.00	6.00
6.450	GT106.4747.030.32.50.L	5.00	0.30	47	8	2.95	4.70	0.60	32.00	57.00	6.00
6.460	GT106.4747.030.37.50.L	5.00	0.30	47	8	2.95	4.70	0.60	37.00	62.00	6.00
6.470	GT106.4747.030.42.50.L	5.00	0.30	47	8	2.95	4.70	0.60	42.00	67.00	6.00



Cutting insert for boring out and profiling

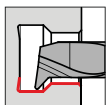

- radial free 47°, tmax 1

for tool holders type GB106 see from page 62

Cutting data page 148

System 106

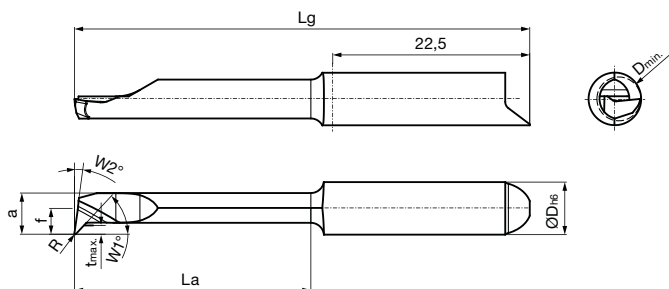

Right hand version shown
Left hand version mirror image



Tool material	Solid carbide		
Type	GT 106	GT 106	GT 106
Surface	S	a	○
	TiN	nano-A	bright

Series no.	25888	25890	25894
Cutting direction	(R)	(R)	(R)

Code no.	Description	D min	R	W1	W2	f	a	t max	La	Lg	D h6
		mm	mm	°	°	mm	mm	mm	mm	mm	mm
6.010	GT106.4747.005.12.50.R.T1	5.00	0.05	47	8	2.95	4.70	1.00	12.00	37.00	6.00
6.020	GT106.4747.005.17.50.R.T1	5.00	0.05	47	8	2.95	4.70	1.00	17.00	42.00	6.00
6.030	GT106.4747.005.22.50.R.T1	5.00	0.05	47	8	2.95	4.70	1.00	22.00	47.00	6.00
6.040	GT106.4747.005.27.50.R.T1	5.00	0.05	47	8	2.95	4.70	1.00	27.00	52.00	6.00
6.050	GT106.4747.005.32.50.R.T1	5.00	0.05	47	8	2.95	4.70	1.00	32.00	57.00	6.00
6.060	GT106.4747.005.37.50.R.T1	5.00	0.05	47	8	2.95	4.70	1.00	37.00	62.00	6.00
6.070	GT106.4747.005.42.50.R.T1	5.00	0.05	47	8	2.95	4.70	1.00	42.00	67.00	6.00
6.110	GT106.4747.010.12.50.R.T1	5.00	0.10	47	8	2.95	4.70	1.00	12.00	37.00	6.00
6.120	GT106.4747.010.17.50.R.T1	5.00	0.10	47	8	2.95	4.70	1.00	17.00	42.00	6.00
6.130	GT106.4747.010.22.50.R.T1	5.00	0.10	47	8	2.95	4.70	1.00	22.00	47.00	6.00
6.140	GT106.4747.010.27.50.R.T1	5.00	0.10	47	8	2.95	4.70	1.00	27.00	52.00	6.00
6.150	GT106.4747.010.32.50.R.T1	5.00	0.10	47	8	2.95	4.70	1.00	32.00	57.00	6.00
6.160	GT106.4747.010.37.50.R.T1	5.00	0.10	47	8	2.95	4.70	1.00	37.00	62.00	6.00
6.170	GT106.4747.010.42.50.R.T1	5.00	0.10	47	8	2.95	4.70	1.00	42.00	67.00	6.00
6.210	GT106.4747.015.12.50.R.T1	5.00	0.15	47	8	2.95	4.70	1.00	12.00	37.00	6.00
6.220	GT106.4747.015.17.50.R.T1	5.00	0.15	47	8	2.95	4.70	1.00	17.00	42.00	6.00
6.230	GT106.4747.015.22.50.R.T1	5.00	0.15	47	8	2.95	4.70	1.00	22.00	47.00	6.00
6.240	GT106.4747.015.27.50.R.T1	5.00	0.15	47	8	2.95	4.70	1.00	27.00	52.00	6.00
6.250	GT106.4747.015.32.50.R.T1	5.00	0.15	47	8	2.95	4.70	1.00	32.00	57.00	6.00
6.260	GT106.4747.015.37.50.R.T1	5.00	0.15	47	8	2.95	4.70	1.00	37.00	62.00	6.00
6.270	GT106.4747.015.42.50.R.T1	5.00	0.15	47	8	2.95	4.70	1.00	42.00	67.00	6.00
6.310	GT106.4747.020.12.50.R.T1	5.00	0.20	47	8	2.95	4.70	1.00	12.00	37.00	6.00
6.320	GT106.4747.020.17.50.R.T1	5.00	0.20	47	8	2.95	4.70	1.00	17.00	42.00	6.00
6.330	GT106.4747.020.22.50.R.T1	5.00	0.20	47	8	2.95	4.70	1.00	22.00	47.00	6.00
6.340	GT106.4747.020.27.50.R.T1	5.00	0.20	47	8	2.95	4.70	1.00	27.00	52.00	6.00
6.350	GT106.4747.020.32.50.R.T1	5.00	0.20	47	8	2.95	4.70	1.00	32.00	57.00	6.00
6.360	GT106.4747.020.37.50.R.T1	5.00	0.20	47	8	2.95	4.70	1.00	37.00	62.00	6.00
6.370	GT106.4747.020.42.50.R.T1	5.00	0.20	47	8	2.95	4.70	1.00	42.00	67.00	6.00
6.410	GT106.4747.030.12.50.R.T1	5.00	0.30	47	8	2.95	4.70	1.00	12.00	37.00	6.00
6.420	GT106.4747.030.17.50.R.T1	5.00	0.30	47	8	2.95	4.70	1.00	17.00	42.00	6.00
6.430	GT106.4747.030.22.50.R.T1	5.00	0.30	47	8	2.95	4.70	1.00	22.00	47.00	6.00
6.440	GT106.4747.030.27.50.R.T1	5.00	0.30	47	8	2.95	4.70	1.00	27.00	52.00	6.00
6.450	GT106.4747.030.32.50.R.T1	5.00	0.30	47	8	2.95	4.70	1.00	32.00	57.00	6.00
6.460	GT106.4747.030.37.50.R.T1	5.00	0.30	47	8	2.95	4.70	1.00	37.00	62.00	6.00
6.470	GT106.4747.030.42.50.R.T1	5.00	0.30	47	8	2.95	4.70	1.00	42.00	67.00	6.00

Series no. **25889** **25891** **25895**Cutting direction   

Code no.	Description	D min	R	W1	W2	f	a	t max	La	Lg	D h6
		mm	mm	°	°	mm	mm	mm	mm	mm	mm
6.010	GT106.4747.005.12.50.L.T1	5.00	0.05	47	8	2.95	4.70	1.00	12.00	37.00	6.00
6.020	GT106.4747.005.17.50.L.T1	5.00	0.05	47	8	2.95	4.70	1.00	17.00	42.00	6.00
6.030	GT106.4747.005.22.50.L.T1	5.00	0.05	47	8	2.95	4.70	1.00	22.00	47.00	6.00
6.040	GT106.4747.005.27.50.L.T1	5.00	0.05	47	8	2.95	4.70	1.00	27.00	52.00	6.00
6.050	GT106.4747.005.32.50.L.T1	5.00	0.05	47	8	2.95	4.70	1.00	32.00	57.00	6.00
6.060	GT106.4747.005.37.50.L.T1	5.00	0.05	47	8	2.95	4.70	1.00	37.00	62.00	6.00
6.070	GT106.4747.005.42.50.L.T1	5.00	0.05	47	8	2.95	4.70	1.00	42.00	67.00	6.00
6.110	GT106.4747.010.12.50.L.T1	5.00	0.10	47	8	2.95	4.70	1.00	12.00	37.00	6.00
6.120	GT106.4747.010.17.50.L.T1	5.00	0.10	47	8	2.95	4.70	1.00	17.00	42.00	6.00
6.130	GT106.4747.010.22.50.L.T1	5.00	0.10	47	8	2.95	4.70	1.00	22.00	47.00	6.00
6.140	GT106.4747.010.27.50.L.T1	5.00	0.10	47	8	2.95	4.70	1.00	27.00	52.00	6.00
6.150	GT106.4747.010.32.50.L.T1	5.00	0.10	47	8	2.95	4.70	1.00	32.00	57.00	6.00
6.160	GT106.4747.010.37.50.L.T1	5.00	0.10	47	8	2.95	4.70	1.00	37.00	62.00	6.00
6.170	GT106.4747.010.42.50.L.T1	5.00	0.10	47	8	2.95	4.70	1.00	42.00	67.00	6.00
6.210	GT106.4747.015.12.50.L.T1	5.00	0.15	47	8	2.95	4.70	1.00	12.00	37.00	6.00
6.220	GT106.4747.015.17.50.L.T1	5.00	0.15	47	8	2.95	4.70	1.00	17.00	42.00	6.00
6.230	GT106.4747.015.22.50.L.T1	5.00	0.15	47	8	2.95	4.70	1.00	22.00	47.00	6.00
6.240	GT106.4747.015.27.50.L.T1	5.00	0.15	47	8	2.95	4.70	1.00	27.00	52.00	6.00
6.250	GT106.4747.015.32.50.L.T1	5.00	0.15	47	8	2.95	4.70	1.00	32.00	57.00	6.00
6.260	GT106.4747.015.37.50.L.T1	5.00	0.15	47	8	2.95	4.70	1.00	37.00	62.00	6.00
6.270	GT106.4747.015.42.50.L.T1	5.00	0.15	47	8	2.95	4.70	1.00	42.00	67.00	6.00
6.310	GT106.4747.020.12.50.L.T1	5.00	0.20	47	8	2.95	4.70	1.00	12.00	37.00	6.00
6.320	GT106.4747.020.17.50.L.T1	5.00	0.20	47	8	2.95	4.70	1.00	17.00	42.00	6.00
6.330	GT106.4747.020.22.50.L.T1	5.00	0.20	47	8	2.95	4.70	1.00	22.00	47.00	6.00
6.340	GT106.4747.020.27.50.L.T1	5.00	0.20	47	8	2.95	4.70	1.00	27.00	52.00	6.00
6.350	GT106.4747.020.32.50.L.T1	5.00	0.20	47	8	2.95	4.70	1.00	32.00	57.00	6.00
6.360	GT106.4747.020.37.50.L.T1	5.00	0.20	47	8	2.95	4.70	1.00	37.00	62.00	6.00
6.370	GT106.4747.020.42.50.L.T1	5.00	0.20	47	8	2.95	4.70	1.00	42.00	67.00	6.00
6.410	GT106.4747.030.12.50.L.T1	5.00	0.30	47	8	2.95	4.70	1.00	12.00	37.00	6.00
6.420	GT106.4747.030.17.50.L.T1	5.00	0.30	47	8	2.95	4.70	1.00	17.00	42.00	6.00
6.430	GT106.4747.030.22.50.L.T1	5.00	0.30	47	8	2.95	4.70	1.00	22.00	47.00	6.00
6.440	GT106.4747.030.27.50.L.T1	5.00	0.30	47	8	2.95	4.70	1.00	27.00	52.00	6.00
6.450	GT106.4747.030.32.50.L.T1	5.00	0.30	47	8	2.95	4.70	1.00	32.00	57.00	6.00
6.460	GT106.4747.030.37.50.L.T1	5.00	0.30	47	8	2.95	4.70	1.00	37.00	62.00	6.00
6.470	GT106.4747.030.42.50.L.T1	5.00	0.30	47	8	2.95	4.70	1.00	42.00	67.00	6.00



Cutting insert for boring out and profiling

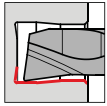

• radial free 8°

for tool holders type GB106 see from page 62

Cutting data page 148

Tool material	Solid carbide		
Type	GT 106	GT 106	GT 106
Surface			
	TiN	nano-A	bright

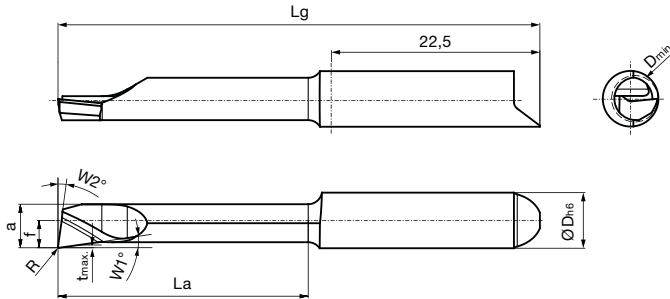

Right hand version shown
Left hand version mirror image



Series no.	25500	25502	25506
Cutting direction			

Code no.	Description	D min	R	W1	W2	f	a	t max	La	Lg	D h6
		mm	mm	°	°	mm	mm	mm	mm	mm	mm
6.010	GT106.0847.005.12.50.R	5.00	0.05	8	8	2.95	4.70	0.30	12.00	37.00	6.00
6.020	GT106.0847.005.17.50.R	5.00	0.05	8	8	2.95	4.70	0.30	17.00	42.00	6.00
6.030	GT106.0847.005.22.50.R	5.00	0.05	8	8	2.95	4.70	0.30	22.00	47.00	6.00
6.040	GT106.0847.005.27.50.R	5.00	0.05	8	8	2.95	4.70	0.30	27.00	52.00	6.00
6.050	GT106.0847.005.32.50.R	5.00	0.05	8	8	2.95	4.70	0.30	32.00	57.00	6.00
6.060	GT106.0847.005.37.50.R	5.00	0.05	8	8	2.95	4.70	0.30	37.00	62.00	6.00
6.070	GT106.0847.005.42.50.R	5.00	0.05	8	8	2.95	4.70	0.30	42.00	67.00	6.00
6.110	GT106.0847.010.12.50.R	5.00	0.10	8	8	2.95	4.70	0.30	12.00	37.00	6.00
6.120	GT106.0847.010.17.50.R	5.00	0.10	8	8	2.95	4.70	0.30	17.00	42.00	6.00
6.130	GT106.0847.010.22.50.R	5.00	0.10	8	8	2.95	4.70	0.30	22.00	47.00	6.00
6.140	GT106.0847.010.27.50.R	5.00	0.10	8	8	2.95	4.70	0.30	27.00	52.00	6.00
6.150	GT106.0847.010.32.50.R	5.00	0.10	8	8	2.95	4.70	0.30	32.00	57.00	6.00
6.160	GT106.0847.010.37.50.R	5.00	0.10	8	8	2.95	4.70	0.30	37.00	62.00	6.00
6.170	GT106.0847.010.42.50.R	5.00	0.10	8	8	2.95	4.70	0.30	42.00	67.00	6.00
6.210	GT106.0847.015.12.50.R	5.00	0.15	8	8	2.95	4.70	0.30	12.00	37.00	6.00
6.220	GT106.0847.015.17.50.R	5.00	0.15	8	8	2.95	4.70	0.30	17.00	42.00	6.00
6.230	GT106.0847.015.22.50.R	5.00	0.15	8	8	2.95	4.70	0.30	22.00	47.00	6.00
6.240	GT106.0847.015.27.50.R	5.00	0.15	8	8	2.95	4.70	0.30	27.00	52.00	6.00
6.250	GT106.0847.015.32.50.R	5.00	0.15	8	8	2.95	4.70	0.30	32.00	57.00	6.00
6.260	GT106.0847.015.37.50.R	5.00	0.15	8	8	2.95	4.70	0.30	37.00	62.00	6.00
6.270	GT106.0847.015.42.50.R	5.00	0.15	8	8	2.95	4.70	0.30	42.00	67.00	6.00
6.310	GT106.0847.020.12.50.R	5.00	0.20	8	8	2.95	4.70	0.30	12.00	37.00	6.00
6.320	GT106.0847.020.17.50.R	5.00	0.20	8	8	2.95	4.70	0.30	17.00	42.00	6.00
6.330	GT106.0847.020.22.50.R	5.00	0.20	8	8	2.95	4.70	0.30	22.00	47.00	6.00
6.340	GT106.0847.020.27.50.R	5.00	0.20	8	8	2.95	4.70	0.30	27.00	52.00	6.00
6.350	GT106.0847.020.32.50.R	5.00	0.20	8	8	2.95	4.70	0.30	32.00	57.00	6.00
6.360	GT106.0847.020.37.50.R	5.00	0.20	8	8	2.95	4.70	0.30	37.00	62.00	6.00
6.370	GT106.0847.020.42.50.R	5.00	0.20	8	8	2.95	4.70	0.30	42.00	67.00	6.00
6.410	GT106.0847.030.12.50.R	5.00	0.30	8	8	2.95	4.70	0.30	12.00	37.00	6.00
6.420	GT106.0847.030.17.50.R	5.00	0.30	8	8	2.95	4.70	0.30	17.00	42.00	6.00
6.430	GT106.0847.030.22.50.R	5.00	0.30	8	8	2.95	4.70	0.30	22.00	47.00	6.00
6.440	GT106.0847.030.27.50.R	5.00	0.30	8	8	2.95	4.70	0.30	27.00	52.00	6.00
6.450	GT106.0847.030.32.50.R	5.00	0.30	8	8	2.95	4.70	0.30	32.00	57.00	6.00
6.460	GT106.0847.030.37.50.R	5.00	0.30	8	8	2.95	4.70	0.30	37.00	62.00	6.00
6.470	GT106.0847.030.42.50.R	5.00	0.30	8	8	2.95	4.70	0.30	42.00	67.00	6.00

Series no. **25501** **25503** **25507**Cutting direction   

Code no.	Description	D min	R	W1	W2	f	a	t max	La	Lg	D h6
		mm	mm	°	°	mm	mm	mm	mm	mm	mm
6.010	GT106.0847.005.12.50.L	5.00	0.05	8	8	2.95	4.70	0.30	12.00	37.00	6.00
6.020	GT106.0847.005.17.50.L	5.00	0.05	8	8	2.95	4.70	0.30	17.00	42.00	6.00
6.030	GT106.0847.005.22.50.L	5.00	0.05	8	8	2.95	4.70	0.30	22.00	47.00	6.00
6.040	GT106.0847.005.27.50.L	5.00	0.05	8	8	2.95	4.70	0.30	27.00	52.00	6.00
6.050	GT106.0847.005.32.50.L	5.00	0.05	8	8	2.95	4.70	0.30	32.00	57.00	6.00
6.060	GT106.0847.005.37.50.L	5.00	0.05	8	8	2.95	4.70	0.30	37.00	62.00	6.00
6.070	GT106.0847.005.42.50.L	5.00	0.05	8	8	2.95	4.70	0.30	42.00	67.00	6.00
6.110	GT106.0847.010.12.50.L	5.00	0.10	8	8	2.95	4.70	0.30	12.00	37.00	6.00
6.120	GT106.0847.010.17.50.L	5.00	0.10	8	8	2.95	4.70	0.30	17.00	42.00	6.00
6.130	GT106.0847.010.22.50.L	5.00	0.10	8	8	2.95	4.70	0.30	22.00	47.00	6.00
6.140	GT106.0847.010.27.50.L	5.00	0.10	8	8	2.95	4.70	0.30	27.00	52.00	6.00
6.150	GT106.0847.010.32.50.L	5.00	0.10	8	8	2.95	4.70	0.30	32.00	57.00	6.00
6.160	GT106.0847.010.37.50.L	5.00	0.10	8	8	2.95	4.70	0.30	37.00	62.00	6.00
6.170	GT106.0847.010.42.50.L	5.00	0.10	8	8	2.95	4.70	0.30	42.00	67.00	6.00
6.210	GT106.0847.015.12.50.L	5.00	0.15	8	8	2.95	4.70	0.30	12.00	37.00	6.00
6.220	GT106.0847.015.17.50.L	5.00	0.15	8	8	2.95	4.70	0.30	17.00	42.00	6.00
6.230	GT106.0847.015.22.50.L	5.00	0.15	8	8	2.95	4.70	0.30	22.00	47.00	6.00
6.240	GT106.0847.015.27.50.L	5.00	0.15	8	8	2.95	4.70	0.30	27.00	52.00	6.00
6.250	GT106.0847.015.32.50.L	5.00	0.15	8	8	2.95	4.70	0.30	32.00	57.00	6.00
6.260	GT106.0847.015.37.50.L	5.00	0.15	8	8	2.95	4.70	0.30	37.00	62.00	6.00
6.270	GT106.0847.015.42.50.L	5.00	0.15	8	8	2.95	4.70	0.30	42.00	67.00	6.00
6.310	GT106.0847.020.12.50.L	5.00	0.20	8	8	2.95	4.70	0.30	12.00	37.00	6.00
6.320	GT106.0847.020.17.50.L	5.00	0.20	8	8	2.95	4.70	0.30	17.00	42.00	6.00
6.330	GT106.0847.020.22.50.L	5.00	0.20	8	8	2.95	4.70	0.30	22.00	47.00	6.00
6.340	GT106.0847.020.27.50.L	5.00	0.20	8	8	2.95	4.70	0.30	27.00	52.00	6.00
6.350	GT106.0847.020.32.50.L	5.00	0.20	8	8	2.95	4.70	0.30	32.00	57.00	6.00
6.360	GT106.0847.020.37.50.L	5.00	0.20	8	8	2.95	4.70	0.30	37.00	62.00	6.00
6.370	GT106.0847.020.42.50.L	5.00	0.20	8	8	2.95	4.70	0.30	42.00	67.00	6.00
6.410	GT106.0847.030.12.50.L	5.00	0.30	8	8	2.95	4.70	0.30	12.00	37.00	6.00
6.420	GT106.0847.030.17.50.L	5.00	0.30	8	8	2.95	4.70	0.30	17.00	42.00	6.00
6.430	GT106.0847.030.22.50.L	5.00	0.30	8	8	2.95	4.70	0.30	22.00	47.00	6.00
6.440	GT106.0847.030.27.50.L	5.00	0.30	8	8	2.95	4.70	0.30	27.00	52.00	6.00
6.450	GT106.0847.030.32.50.L	5.00	0.30	8	8	2.95	4.70	0.30	32.00	57.00	6.00
6.460	GT106.0847.030.37.50.L	5.00	0.30	8	8	2.95	4.70	0.30	37.00	62.00	6.00
6.470	GT106.0847.030.42.50.L	5.00	0.30	8	8	2.95	4.70	0.30	42.00	67.00	6.00



Cutting insert for boring out and profiling

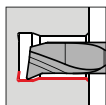

• WIPER-geometry

for tool holders type GB106 see from page 62

Cutting data page 148

System 106

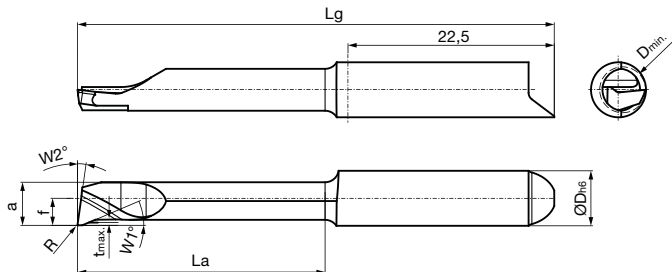

Right hand version shown
Left hand version mirror image





Tool material	Solid carbide		
Type	GJ 106	GJ 106	GJ 106
Surface			
	TiN	nano-A	bright

Series no. **25848** **25850** **25854**

Cutting direction

Code no.	Description	D min	R	W1	W2	f	a	t max	La	Lg	D h6
		mm	mm	°	°	mm	mm	mm	mm	mm	mm
6.010	GJ106.2347.005.12.50.R	5.00	0.05	23	8	2.95	4.70	0.30	12.00	37.00	6.00
6.020	GJ106.2347.005.17.50.R	5.00	0.05	23	8	2.95	4.70	0.30	17.00	42.00	6.00
6.030	GJ106.2347.005.22.50.R	5.00	0.05	23	8	2.95	4.70	0.30	22.00	47.00	6.00
6.040	GJ106.2347.005.27.50.R	5.00	0.05	23	8	2.95	4.70	0.30	27.00	52.00	6.00
6.050	GJ106.2347.005.32.50.R	5.00	0.05	23	8	2.95	4.70	0.30	32.00	57.00	6.00
6.060	GJ106.2347.005.37.50.R	5.00	0.05	23	8	2.95	4.70	0.30	37.00	62.00	6.00
6.070	GJ106.2347.005.42.50.R	5.00	0.05	23	8	2.95	4.70	0.30	42.00	67.00	6.00
6.110	GJ106.2347.010.12.50.R	5.00	0.10	23	8	2.95	4.70	0.30	12.00	37.00	6.00
6.120	GJ106.2347.010.17.50.R	5.00	0.10	23	8	2.95	4.70	0.30	17.00	42.00	6.00
6.130	GJ106.2347.010.22.50.R	5.00	0.10	23	8	2.95	4.70	0.30	22.00	47.00	6.00
6.140	GJ106.2347.010.27.50.R	5.00	0.10	23	8	2.95	4.70	0.30	27.00	52.00	6.00
6.150	GJ106.2347.010.32.50.R	5.00	0.10	23	8	2.95	4.70	0.30	32.00	57.00	6.00
6.160	GJ106.2347.010.37.50.R	5.00	0.10	23	8	2.95	4.70	0.30	37.00	62.00	6.00
6.170	GJ106.2347.010.42.50.R	5.00	0.10	23	8	2.95	4.70	0.30	42.00	67.00	6.00
6.210	GJ106.2347.015.12.50.R	5.00	0.15	23	8	2.95	4.70	0.30	12.00	37.00	6.00
6.220	GJ106.2347.015.17.50.R	5.00	0.15	23	8	2.95	4.70	0.30	17.00	42.00	6.00
6.230	GJ106.2347.015.22.50.R	5.00	0.15	23	8	2.95	4.70	0.30	22.00	47.00	6.00
6.240	GJ106.2347.015.27.50.R	5.00	0.15	23	8	2.95	4.70	0.30	27.00	52.00	6.00
6.250	GJ106.2347.015.32.50.R	5.00	0.15	23	8	2.95	4.70	0.30	32.00	57.00	6.00
6.260	GJ106.2347.015.37.50.R	5.00	0.15	23	8	2.95	4.70	0.30	37.00	62.00	6.00
6.270	GJ106.2347.015.42.50.R	5.00	0.15	23	8	2.95	4.70	0.30	42.00	67.00	6.00
6.310	GJ106.2347.020.12.50.R	5.00	0.20	23	8	2.95	4.70	0.30	12.00	37.00	6.00
6.320	GJ106.2347.020.17.50.R	5.00	0.20	23	8	2.95	4.70	0.30	17.00	42.00	6.00
6.330	GJ106.2347.020.22.50.R	5.00	0.20	23	8	2.95	4.70	0.30	22.00	47.00	6.00
6.340	GJ106.2347.020.27.50.R	5.00	0.20	23	8	2.95	4.70	0.30	27.00	52.00	6.00
6.350	GJ106.2347.020.32.50.R	5.00	0.20	23	8	2.95	4.70	0.30	32.00	57.00	6.00
6.360	GJ106.2347.020.37.50.R	5.00	0.20	23	8	2.95	4.70	0.30	37.00	62.00	6.00
6.370	GJ106.2347.020.42.50.R	5.00	0.20	23	8	2.95	4.70	0.30	42.00	67.00	6.00
6.410	GJ106.2347.030.12.50.R	5.00	0.30	23	8	2.95	4.70	0.30	12.00	37.00	6.00
6.420	GJ106.2347.030.17.50.R	5.00	0.30	23	8	2.95	4.70	0.30	17.00	42.00	6.00
6.430	GJ106.2347.030.22.50.R	5.00	0.30	23	8	2.95	4.70	0.30	22.00	47.00	6.00
6.440	GJ106.2347.030.27.50.R	5.00	0.30	23	8	2.95	4.70	0.30	27.00	52.00	6.00
6.450	GJ106.2347.030.32.50.R	5.00	0.30	23	8	2.95	4.70	0.30	32.00	57.00	6.00
6.460	GJ106.2347.030.37.50.R	5.00	0.30	23	8	2.95	4.70	0.30	37.00	62.00	6.00
6.470	GJ106.2347.030.42.50.R	5.00	0.30	23	8	2.95	4.70	0.30	42.00	67.00	6.00

Series no. **25849** **25851** **25855**Cutting direction   

Code no.	Description	D min	R	W1	W2	f	a	t max	La	Lg	D h6
		mm	mm	°	°	mm	mm	mm	mm	mm	mm
6.010	GJ106.2347.005.12.50.L	5.00	0.05	23	8	2.95	4.70	0.30	12.00	37.00	6.00
6.020	GJ106.2347.005.17.50.L	5.00	0.05	23	8	2.95	4.70	0.30	17.00	42.00	6.00
6.030	GJ106.2347.005.22.50.L	5.00	0.05	23	8	2.95	4.70	0.30	22.00	47.00	6.00
6.040	GJ106.2347.005.27.50.L	5.00	0.05	23	8	2.95	4.70	0.30	27.00	52.00	6.00
6.050	GJ106.2347.005.32.50.L	5.00	0.05	23	8	2.95	4.70	0.30	32.00	57.00	6.00
6.060	GJ106.2347.005.37.50.L	5.00	0.05	23	8	2.95	4.70	0.30	37.00	62.00	6.00
6.070	GJ106.2347.005.42.50.L	5.00	0.05	23	8	2.95	4.70	0.30	42.00	67.00	6.00
6.110	GJ106.2347.010.12.50.L	5.00	0.10	23	8	2.95	4.70	0.30	12.00	37.00	6.00
6.120	GJ106.2347.010.17.50.L	5.00	0.10	23	8	2.95	4.70	0.30	17.00	42.00	6.00
6.130	GJ106.2347.010.22.50.L	5.00	0.10	23	8	2.95	4.70	0.30	22.00	47.00	6.00
6.140	GJ106.2347.010.27.50.L	5.00	0.10	23	8	2.95	4.70	0.30	27.00	52.00	6.00
6.150	GJ106.2347.010.32.50.L	5.00	0.10	23	8	2.95	4.70	0.30	32.00	57.00	6.00
6.160	GJ106.2347.010.37.50.L	5.00	0.10	23	8	2.95	4.70	0.30	37.00	62.00	6.00
6.170	GJ106.2347.010.42.50.L	5.00	0.10	23	8	2.95	4.70	0.30	42.00	67.00	6.00
6.210	GJ106.2347.015.12.50.L	5.00	0.15	23	8	2.95	4.70	0.30	12.00	37.00	6.00
6.220	GJ106.2347.015.17.50.L	5.00	0.15	23	8	2.95	4.70	0.30	17.00	42.00	6.00
6.230	GJ106.2347.015.22.50.L	5.00	0.15	23	8	2.95	4.70	0.30	22.00	47.00	6.00
6.240	GJ106.2347.015.27.50.L	5.00	0.15	23	8	2.95	4.70	0.30	27.00	52.00	6.00
6.250	GJ106.2347.015.32.50.L	5.00	0.15	23	8	2.95	4.70	0.30	32.00	57.00	6.00
6.260	GJ106.2347.015.37.50.L	5.00	0.15	23	8	2.95	4.70	0.30	37.00	62.00	6.00
6.270	GJ106.2347.015.42.50.L	5.00	0.15	23	8	2.95	4.70	0.30	42.00	67.00	6.00
6.310	GJ106.2347.020.12.50.L	5.00	0.20	23	8	2.95	4.70	0.30	12.00	37.00	6.00
6.320	GJ106.2347.020.17.50.L	5.00	0.20	23	8	2.95	4.70	0.30	17.00	42.00	6.00
6.330	GJ106.2347.020.22.50.L	5.00	0.20	23	8	2.95	4.70	0.30	22.00	47.00	6.00
6.340	GJ106.2347.020.27.50.L	5.00	0.20	23	8	2.95	4.70	0.30	27.00	52.00	6.00
6.350	GJ106.2347.020.32.50.L	5.00	0.20	23	8	2.95	4.70	0.30	32.00	57.00	6.00
6.360	GJ106.2347.020.37.50.L	5.00	0.20	23	8	2.95	4.70	0.30	37.00	62.00	6.00
6.370	GJ106.2347.020.42.50.L	5.00	0.20	23	8	2.95	4.70	0.30	42.00	67.00	6.00
6.410	GJ106.2347.030.12.50.L	5.00	0.30	23	8	2.95	4.70	0.30	12.00	37.00	6.00
6.420	GJ106.2347.030.17.50.L	5.00	0.30	23	8	2.95	4.70	0.30	17.00	42.00	6.00
6.430	GJ106.2347.030.22.50.L	5.00	0.30	23	8	2.95	4.70	0.30	22.00	47.00	6.00
6.440	GJ106.2347.030.27.50.L	5.00	0.30	23	8	2.95	4.70	0.30	27.00	52.00	6.00
6.450	GJ106.2347.030.32.50.L	5.00	0.30	23	8	2.95	4.70	0.30	32.00	57.00	6.00
6.460	GJ106.2347.030.37.50.L	5.00	0.30	23	8	2.95	4.70	0.30	37.00	62.00	6.00
6.470	GJ106.2347.030.42.50.L	5.00	0.30	23	8	2.95	4.70	0.30	42.00	67.00	6.00



Cutting insert for back boring and profiling

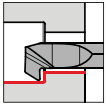

• radial free 32°

for tool holders type GB106 see from page 62

Cutting data page 148

Tool material	Solid carbide		
	GT 106	GT 106	GT 106
Type			
Surface	S	a	○
	TiN	nano-A	bright

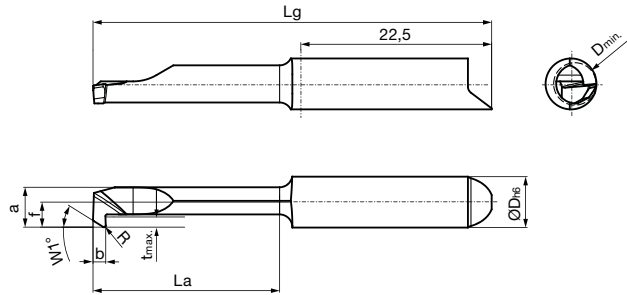

Right hand version shown
Left hand version mirror image

Series no.	25856	25858	25862
Cutting direction	(R)	(R)	(R)

Code no.	Description	D min	R	W1	f	a	t max	La	Lg	D h6
		mm	mm	°	mm	mm	mm	mm	mm	mm
6.010	GT106.3247.020.12.50.R	5.00	0.20	32	2.95	4.70	1.20	12.00	37.00	6.00
6.020	GT106.3247.020.17.50.R	5.00	0.20	32	2.95	4.70	1.20	17.00	42.00	6.00
6.030	GT106.3247.020.22.50.R	5.00	0.20	32	2.95	4.70	1.20	22.00	47.00	6.00
6.040	GT106.3247.020.27.50.R	5.00	0.20	32	2.95	4.70	1.20	27.00	52.00	6.00
6.050	GT106.3247.020.32.50.R	5.00	0.20	32	2.95	4.70	1.20	32.00	57.00	6.00
6.060	GT106.3247.020.37.50.R	5.00	0.20	32	2.95	4.70	1.20	37.00	62.00	6.00
6.070	GT106.3247.020.42.50.R	5.00	0.20	32	2.95	4.70	1.20	42.00	67.00	6.00

Series no.	25857	25859	25863
Cutting direction	(L)	(L)	(L)

Code no.	Description	D min	R	W1	f	a	t max	La	Lg	D h6
		mm	mm	°	mm	mm	mm	mm	mm	mm
6.010	GT106.3247.020.12.50.L	5.00	0.20	32	2.95	4.70	1.20	12.00	37.00	6.00
6.020	GT106.3247.020.17.50.L	5.00	0.20	32	2.95	4.70	1.20	17.00	42.00	6.00
6.030	GT106.3247.020.22.50.L	5.00	0.20	32	2.95	4.70	1.20	22.00	47.00	6.00
6.040	GT106.3247.020.27.50.L	5.00	0.20	32	2.95	4.70	1.20	27.00	52.00	6.00
6.050	GT106.3247.020.32.50.L	5.00	0.20	32	2.95	4.70	1.20	32.00	57.00	6.00
6.060	GT106.3247.020.37.50.L	5.00	0.20	32	2.95	4.70	1.20	37.00	62.00	6.00
6.070	GT106.3247.020.42.50.L	5.00	0.20	32	2.95	4.70	1.20	42.00	67.00	6.00



Cutting insert for boring out and chamfering

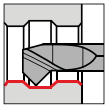

• 45° both sides

for tool holders type GB106 see from page 62

Cutting data page 148

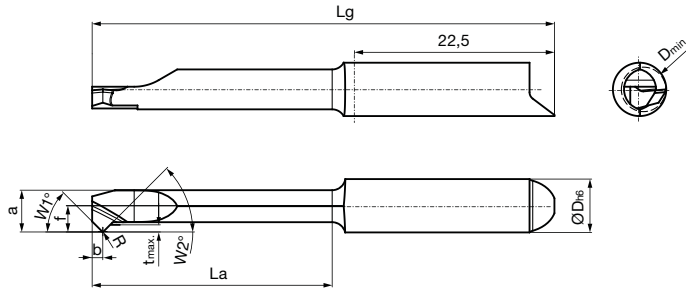

Right hand version shown
Left hand version mirror image

Tool material	Solid carbide		
Type	GT 106	GT 106	GT 106
Surface	S	a	○
	TiN	nano-A	bright





System 106

Series no. **25864** **25866** **25870**

Cutting direction

Code no.	Description	D min	R	W1	W2	f	a	t max	La	Lg	D h6
		mm	mm	°	°	mm	mm	mm	mm	mm	mm
6.010	GT106.4547.010.12.50.R	5.00	0.10	45	45	2.95	4.70	0.80	12.00	37.00	6.00
6.020	GT106.4547.010.17.50.R	5.00	0.10	45	45	2.95	4.70	0.80	17.00	42.00	6.00
6.030	GT106.4547.010.22.50.R	5.00	0.10	45	45	2.95	4.70	0.80	22.00	47.00	6.00
6.040	GT106.4547.010.27.50.R	5.00	0.10	45	45	2.95	4.70	0.80	27.00	52.00	6.00
6.050	GT106.4547.010.32.50.R	5.00	0.10	45	45	2.95	4.70	0.80	32.00	57.00	6.00
6.060	GT106.4547.010.37.50.R	5.00	0.10	45	45	2.95	4.70	0.80	37.00	62.00	6.00
6.070	GT106.4547.010.42.50.R	5.00	0.10	45	45	2.95	4.70	0.80	42.00	67.00	6.00
6.110	GT106.4547.015.12.50.R	5.00	0.15	45	45	2.95	4.70	0.80	12.00	37.00	6.00
6.120	GT106.4547.015.17.50.R	5.00	0.15	45	45	2.95	4.70	0.80	17.00	42.00	6.00
6.130	GT106.4547.015.22.50.R	5.00	0.15	45	45	2.95	4.70	0.80	22.00	47.00	6.00
6.140	GT106.4547.015.27.50.R	5.00	0.15	45	45	2.95	4.70	0.80	27.00	52.00	6.00
6.150	GT106.4547.015.32.50.R	5.00	0.15	45	45	2.95	4.70	0.80	32.00	57.00	6.00
6.160	GT106.4547.015.37.50.R	5.00	0.15	45	45	2.95	4.70	0.80	37.00	62.00	6.00
6.170	GT106.4547.015.42.50.R	5.00	0.15	45	45	2.95	4.70	0.80	42.00	67.00	6.00
6.210	GT106.4547.020.12.50.R	5.00	0.20	45	45	2.95	4.70	0.80	12.00	37.00	6.00
6.220	GT106.4547.020.17.50.R	5.00	0.20	45	45	2.95	4.70	0.80	17.00	42.00	6.00
6.230	GT106.4547.020.22.50.R	5.00	0.20	45	45	2.95	4.70	0.80	22.00	47.00	6.00
6.240	GT106.4547.020.27.50.R	5.00	0.20	45	45	2.95	4.70	0.80	27.00	52.00	6.00
6.250	GT106.4547.020.32.50.R	5.00	0.20	45	45	2.95	4.70	0.80	32.00	57.00	6.00
6.260	GT106.4547.020.37.50.R	5.00	0.20	45	45	2.95	4.70	0.80	37.00	62.00	6.00
6.270	GT106.4547.020.42.50.R	5.00	0.20	45	45	2.95	4.70	0.80	42.00	67.00	6.00
6.310	GT106.4547.030.12.50.R	5.00	0.30	45	45	2.95	4.70	0.80	12.00	37.00	6.00
6.320	GT106.4547.030.17.50.R	5.00	0.30	45	45	2.95	4.70	0.80	17.00	42.00	6.00
6.330	GT106.4547.030.22.50.R	5.00	0.30	45	45	2.95	4.70	0.80	22.00	47.00	6.00
6.340	GT106.4547.030.27.50.R	5.00	0.30	45	45	2.95	4.70	0.80	27.00	52.00	6.00
6.350	GT106.4547.030.32.50.R	5.00	0.30	45	45	2.95	4.70	0.80	32.00	57.00	6.00
6.360	GT106.4547.030.37.50.R	5.00	0.30	45	45	2.95	4.70	0.80	37.00	62.00	6.00
6.370	GT106.4547.030.42.50.R	5.00	0.30	45	45	2.95	4.70	0.80	42.00	67.00	6.00

Series no. **25865** **25867** **25871**Cutting direction   

Code no.	Description	D min	R	W1	W2	f	a	t max	La	Lg	D h6
		mm	mm	°	°	mm	mm	mm	mm	mm	mm
6.010	GT106.4547.010.12.50.L	5.00	0.10	45	45	2.95	4.70	0.80	12.00	37.00	6.00
6.020	GT106.4547.010.17.50.L	5.00	0.10	45	45	2.95	4.70	0.80	17.00	42.00	6.00
6.030	GT106.4547.010.22.50.L	5.00	0.10	45	45	2.95	4.70	0.80	22.00	47.00	6.00
6.040	GT106.4547.010.27.50.L	5.00	0.10	45	45	2.95	4.70	0.80	27.00	52.00	6.00
6.050	GT106.4547.010.32.50.L	5.00	0.10	45	45	2.95	4.70	0.80	32.00	57.00	6.00
6.060	GT106.4547.010.37.50.L	5.00	0.10	45	45	2.95	4.70	0.80	37.00	62.00	6.00
6.070	GT106.4547.010.42.50.L	5.00	0.10	45	45	2.95	4.70	0.80	42.00	67.00	6.00
6.110	GT106.4547.015.12.50.L	5.00	0.15	45	45	2.95	4.70	0.80	12.00	37.00	6.00
6.120	GT106.4547.015.17.50.L	5.00	0.15	45	45	2.95	4.70	0.80	17.00	42.00	6.00
6.130	GT106.4547.015.22.50.L	5.00	0.15	45	45	2.95	4.70	0.80	22.00	47.00	6.00
6.140	GT106.4547.015.27.50.L	5.00	0.15	45	45	2.95	4.70	0.80	27.00	52.00	6.00
6.150	GT106.4547.015.32.50.L	5.00	0.15	45	45	2.95	4.70	0.80	32.00	57.00	6.00
6.160	GT106.4547.015.37.50.L	5.00	0.15	45	45	2.95	4.70	0.80	37.00	62.00	6.00
6.170	GT106.4547.015.42.50.L	5.00	0.15	45	45	2.95	4.70	0.80	42.00	67.00	6.00
6.210	GT106.4547.020.12.50.L	5.00	0.20	45	45	2.95	4.70	0.80	12.00	37.00	6.00
6.220	GT106.4547.020.17.50.L	5.00	0.20	45	45	2.95	4.70	0.80	17.00	42.00	6.00
6.230	GT106.4547.020.22.50.L	5.00	0.20	45	45	2.95	4.70	0.80	22.00	47.00	6.00
6.240	GT106.4547.020.27.50.L	5.00	0.20	45	45	2.95	4.70	0.80	27.00	52.00	6.00
6.250	GT106.4547.020.32.50.L	5.00	0.20	45	45	2.95	4.70	0.80	32.00	57.00	6.00
6.260	GT106.4547.020.37.50.L	5.00	0.20	45	45	2.95	4.70	0.80	37.00	62.00	6.00
6.270	GT106.4547.020.42.50.L	5.00	0.20	45	45	2.95	4.70	0.80	42.00	67.00	6.00
6.310	GT106.4547.030.12.50.L	5.00	0.30	45	45	2.95	4.70	0.80	12.00	37.00	6.00
6.320	GT106.4547.030.17.50.L	5.00	0.30	45	45	2.95	4.70	0.80	17.00	42.00	6.00
6.330	GT106.4547.030.22.50.L	5.00	0.30	45	45	2.95	4.70	0.80	22.00	47.00	6.00
6.340	GT106.4547.030.27.50.L	5.00	0.30	45	45	2.95	4.70	0.80	27.00	52.00	6.00
6.350	GT106.4547.030.32.50.L	5.00	0.30	45	45	2.95	4.70	0.80	32.00	57.00	6.00
6.360	GT106.4547.030.37.50.L	5.00	0.30	45	45	2.95	4.70	0.80	37.00	62.00	6.00
6.370	GT106.4547.030.42.50.L	5.00	0.30	45	45	2.95	4.70	0.80	42.00	67.00	6.00



Cutting insert for internal grooving, straight slots

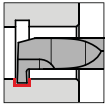

- grooving depth up to 1.2 mm

for tool holders type GB106 see from page 62

Cutting data page 148

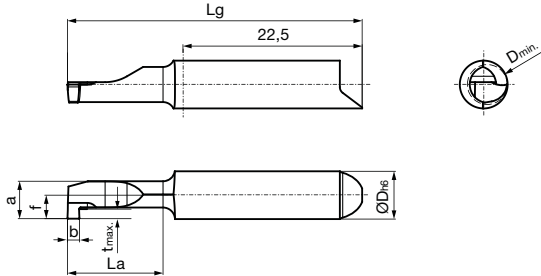

Right hand version shown
Left hand version mirror image

Tool material	Solid carbide		
Type	GE 106	GE 106	GE 106
Surface			
	TiN	nano-A	bright



Series no. **25872** **25874** **25878**

Cutting direction

Code no.	Description	D min	b	f	a	t max	La	Lg	D h6
		mm	mm	mm	mm	mm	mm	mm	mm
6.010	GE106.0100.000.12.50.R	5.00	1.00	2.95	4.70	1.20	12.00	37.00	6.00
6.020	GE106.0100.000.17.50.R	5.00	1.00	2.95	4.70	1.20	17.00	42.00	6.00
6.030	GE106.0100.000.22.50.R	5.00	1.00	2.95	4.70	1.20	22.00	47.00	6.00
6.040	GE106.0100.000.27.50.R	5.00	1.00	2.95	4.70	1.20	27.00	52.00	6.00
6.050	GE106.0100.000.32.50.R	5.00	1.00	2.95	4.70	1.20	32.00	57.00	6.00
6.060	GE106.0100.000.37.50.R	5.00	1.00	2.95	4.70	1.20	37.00	62.00	6.00
6.070	GE106.0100.000.42.50.R	5.00	1.00	2.95	4.70	1.20	42.00	67.00	6.00
6.110	GE106.0150.000.12.50.R	5.00	1.50	2.95	4.70	1.20	12.00	37.00	6.00
6.120	GE106.0150.000.17.50.R	5.00	1.50	2.95	4.70	1.20	17.00	42.00	6.00
6.130	GE106.0150.000.22.50.R	5.00	1.50	2.95	4.70	1.20	22.00	47.00	6.00
6.140	GE106.0150.000.27.50.R	5.00	1.50	2.95	4.70	1.20	27.00	52.00	6.00
6.150	GE106.0150.000.32.50.R	5.00	1.50	2.95	4.70	1.20	32.00	57.00	6.00
6.160	GE106.0150.000.37.50.R	5.00	1.50	2.95	4.70	1.20	37.00	62.00	6.00
6.170	GE106.0150.000.42.50.R	5.00	1.50	2.95	4.70	1.20	42.00	67.00	6.00
6.210	GE106.0200.000.12.50.R	5.00	2.00	2.95	4.70	1.20	12.00	37.00	6.00
6.220	GE106.0200.000.17.50.R	5.00	2.00	2.95	4.70	1.20	17.00	42.00	6.00
6.230	GE106.0200.000.22.50.R	5.00	2.00	2.95	4.70	1.20	22.00	47.00	6.00
6.240	GE106.0200.000.27.50.R	5.00	2.00	2.95	4.70	1.20	27.00	52.00	6.00
6.250	GE106.0200.000.32.50.R	5.00	2.00	2.95	4.70	1.20	32.00	57.00	6.00
6.260	GE106.0200.000.37.50.R	5.00	2.00	2.95	4.70	1.20	37.00	62.00	6.00
6.270	GE106.0200.000.42.50.R	5.00	2.00	2.95	4.70	1.20	42.00	67.00	6.00

System 106



Series no. **25873** **25875** **25879**

Cutting direction   

System 106

Code no.	Description	D min	b	f	a	t max	La	Lg	D h6
		mm	mm	mm	mm	mm	mm	mm	mm
6.010	GE106.0100.000.12.50.L	5.00	1.00	2.95	4.70	1.20	12.00	37.00	6.00
6.020	GE106.0100.000.17.50.L	5.00	1.00	2.95	4.70	1.20	17.00	42.00	6.00
6.030	GE106.0100.000.22.50.L	5.00	1.00	2.95	4.70	1.20	22.00	47.00	6.00
6.040	GE106.0100.000.27.50.L	5.00	1.00	2.95	4.70	1.20	27.00	52.00	6.00
6.050	GE106.0100.000.32.50.L	5.00	1.00	2.95	4.70	1.20	32.00	57.00	6.00
6.060	GE106.0100.000.37.50.L	5.00	1.00	2.95	4.70	1.20	37.00	62.00	6.00
6.070	GE106.0100.000.42.50.L	5.00	1.00	2.95	4.70	1.20	42.00	67.00	6.00
6.110	GE106.0150.000.12.50.L	5.00	1.50	2.95	4.70	1.20	12.00	37.00	6.00
6.120	GE106.0150.000.17.50.L	5.00	1.50	2.95	4.70	1.20	17.00	42.00	6.00
6.130	GE106.0150.000.22.50.L	5.00	1.50	2.95	4.70	1.20	22.00	47.00	6.00
6.140	GE106.0150.000.27.50.L	5.00	1.50	2.95	4.70	1.20	27.00	52.00	6.00
6.150	GE106.0150.000.32.50.L	5.00	1.50	2.95	4.70	1.20	32.00	57.00	6.00
6.160	GE106.0150.000.37.50.L	5.00	1.50	2.95	4.70	1.20	37.00	62.00	6.00
6.170	GE106.0150.000.42.50.L	5.00	1.50	2.95	4.70	1.20	42.00	67.00	6.00
6.210	GE106.0200.000.12.50.L	5.00	2.00	2.95	4.70	1.20	12.00	37.00	6.00
6.220	GE106.0200.000.17.50.L	5.00	2.00	2.95	4.70	1.20	17.00	42.00	6.00
6.230	GE106.0200.000.22.50.L	5.00	2.00	2.95	4.70	1.20	22.00	47.00	6.00
6.240	GE106.0200.000.27.50.L	5.00	2.00	2.95	4.70	1.20	27.00	52.00	6.00
6.250	GE106.0200.000.32.50.L	5.00	2.00	2.95	4.70	1.20	32.00	57.00	6.00
6.260	GE106.0200.000.37.50.L	5.00	2.00	2.95	4.70	1.20	37.00	62.00	6.00
6.270	GE106.0200.000.42.50.L	5.00	2.00	2.95	4.70	1.20	42.00	67.00	6.00



Cutting insert for internal grooving, full radius slots

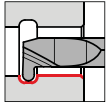

• full radius R0.5-R1.0

for tool holders type GB106 see from page 62

Cutting data page 148

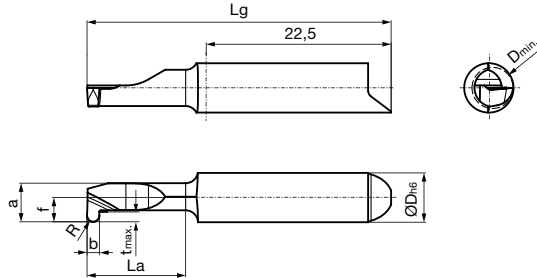

Right hand version shown
Left hand version mirror image

Tool material	Solid carbide		
Type	GE 106	GE 106	GE 106
Surface	S	a	○
	TiN	nano-A	bright

Series no. **25880** **25882** **25886**

Cutting direction **(R)** **(R)** **(R)**

Code no.	Description	D min	b	R	f	a	t max	La	Lg	D h6
		mm	mm	mm	mm	mm	mm	mm	mm	mm
6.010	GE106.0100.050.12.50.R	5.00	1.00	0.50	2.95	4.70	1.20	12.00	37.00	6.00
6.020	GE106.0100.050.17.50.R	5.00	1.00	0.50	2.95	4.70	1.20	17.00	42.00	6.00
6.030	GE106.0100.050.22.50.R	5.00	1.00	0.50	2.95	4.70	1.20	22.00	47.00	6.00
6.040	GE106.0100.050.27.50.R	5.00	1.00	0.50	2.95	4.70	1.20	27.00	52.00	6.00
6.050	GE106.0100.050.32.50.R	5.00	1.00	0.50	2.95	4.70	1.20	32.00	57.00	6.00
6.060	GE106.0100.050.37.50.R	5.00	1.00	0.50	2.95	4.70	1.20	37.00	62.00	6.00
6.070	GE106.0100.050.42.50.R	5.00	1.00	0.50	2.95	4.70	1.20	42.00	67.00	6.00
6.110	GE106.0150.075.12.50.R	5.00	1.50	0.75	2.95	4.70	1.20	12.00	37.00	6.00
6.120	GE106.0150.075.17.50.R	5.00	1.50	0.75	2.95	4.70	1.20	17.00	42.00	6.00
6.130	GE106.0150.075.22.50.R	5.00	1.50	0.75	2.95	4.70	1.20	22.00	47.00	6.00
6.140	GE106.0150.075.27.50.R	5.00	1.50	0.75	2.95	4.70	1.20	27.00	52.00	6.00
6.150	GE106.0150.075.32.50.R	5.00	1.50	0.75	2.95	4.70	1.20	32.00	57.00	6.00
6.160	GE106.0150.075.37.50.R	5.00	1.50	0.75	2.95	4.70	1.20	37.00	62.00	6.00
6.170	GE106.0150.075.42.50.R	5.00	1.50	0.75	2.95	4.70	1.20	42.00	67.00	6.00
6.210	GE106.0200.100.12.50.R	5.00	2.00	1.00	2.95	4.70	1.20	12.00	37.00	6.00
6.220	GE106.0200.100.17.50.R	5.00	2.00	1.00	2.95	4.70	1.20	17.00	42.00	6.00
6.230	GE106.0200.100.22.50.R	5.00	2.00	1.00	2.95	4.70	1.20	22.00	47.00	6.00
6.240	GE106.0200.100.27.50.R	5.00	2.00	1.00	2.95	4.70	1.20	27.00	52.00	6.00
6.250	GE106.0200.100.32.50.R	5.00	2.00	1.00	2.95	4.70	1.20	32.00	57.00	6.00
6.260	GE106.0200.100.37.50.R	5.00	2.00	1.00	2.95	4.70	1.20	37.00	62.00	6.00
6.270	GE106.0200.100.42.50.R	5.00	2.00	1.00	2.95	4.70	1.20	42.00	67.00	6.00

System 106



Series no. **25881** **25883** **25887**

Cutting direction

System 106

Code no.	Description	D min	b	R	f	a	t max	La	Lg	D h6
		mm	mm	mm	mm	mm	mm	mm	mm	mm
6.010	GE106.0100.050.12.50.L	5.00	1.00	0.50	2.95	4.70	1.20	12.00	37.00	6.00
6.020	GE106.0100.050.17.50.L	5.00	1.00	0.50	2.95	4.70	1.20	17.00	42.00	6.00
6.030	GE106.0100.050.22.50.L	5.00	1.00	0.50	2.95	4.70	1.20	22.00	47.00	6.00
6.040	GE106.0100.050.27.50.L	5.00	1.00	0.50	2.95	4.70	1.20	27.00	52.00	6.00
6.050	GE106.0100.050.32.50.L	5.00	1.00	0.50	2.95	4.70	1.20	32.00	57.00	6.00
6.060	GE106.0100.050.37.50.L	5.00	1.00	0.50	2.95	4.70	1.20	37.00	62.00	6.00
6.070	GE106.0100.050.42.50.L	5.00	1.00	0.50	2.95	4.70	1.20	42.00	67.00	6.00
6.110	GE106.0150.075.12.50.L	5.00	1.50	0.75	2.95	4.70	1.20	12.00	37.00	6.00
6.120	GE106.0150.075.17.50.L	5.00	1.50	0.75	2.95	4.70	1.20	17.00	42.00	6.00
6.130	GE106.0150.075.22.50.L	5.00	1.50	0.75	2.95	4.70	1.20	22.00	47.00	6.00
6.140	GE106.0150.075.27.50.L	5.00	1.50	0.75	2.95	4.70	1.20	27.00	52.00	6.00
6.150	GE106.0150.075.32.50.L	5.00	1.50	0.75	2.95	4.70	1.20	32.00	57.00	6.00
6.160	GE106.0150.075.37.50.L	5.00	1.50	0.75	2.95	4.70	1.20	37.00	62.00	6.00
6.170	GE106.0150.075.42.50.L	5.00	1.50	0.75	2.95	4.70	1.20	42.00	67.00	6.00
6.210	GE106.0200.100.12.50.L	5.00	2.00	1.00	2.95	4.70	1.20	12.00	37.00	6.00
6.220	GE106.0200.100.17.50.L	5.00	2.00	1.00	2.95	4.70	1.20	17.00	42.00	6.00
6.230	GE106.0200.100.22.50.L	5.00	2.00	1.00	2.95	4.70	1.20	22.00	47.00	6.00
6.240	GE106.0200.100.27.50.L	5.00	2.00	1.00	2.95	4.70	1.20	27.00	52.00	6.00
6.250	GE106.0200.100.32.50.L	5.00	2.00	1.00	2.95	4.70	1.20	32.00	57.00	6.00
6.260	GE106.0200.100.37.50.L	5.00	2.00	1.00	2.95	4.70	1.20	37.00	62.00	6.00
6.270	GE106.0200.100.42.50.L	5.00	2.00	1.00	2.95	4.70	1.20	42.00	67.00	6.00



Cutting insert for boring out and profiling

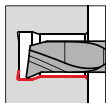

• radial free 23°

for tool holders type GB106 see from page 62

Cutting data page 148

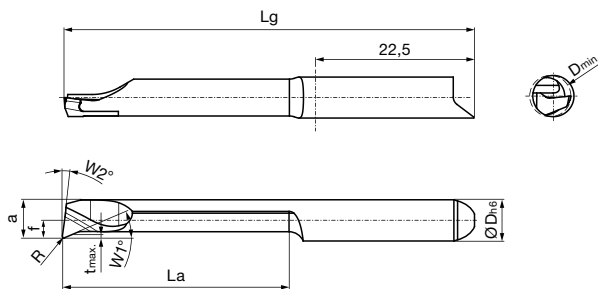

Right hand version shown
Left hand version mirror image

Tool material	Solid carbide		
	GT 106	GT 106	GT 106
Type			
Surface	S	a	○
	TiN	nano-A	bright



Series no.	25700	25702	25706
Cutting direction	(R)	(R)	(R)

Code no.	Description	D min	R	W1	W2	f	a	t max	La	Lg	D h6
		mm	mm	°	°	mm	mm	mm	mm	mm	mm
6.001	GT106.2357.015.27.60.R	6.00	0.15	23	8	2.70	5.70	0.30	27.00	52.00	6.00
6.002	GT106.2357.015.32.60.R	6.00	0.15	23	8	2.70	5.70	0.30	32.00	57.00	6.00
6.003	GT106.2357.015.37.60.R	6.00	0.15	23	8	2.70	5.70	0.30	37.00	62.00	6.00
6.004	GT106.2357.015.42.60.R	6.00	0.15	23	8	2.70	5.70	0.30	42.00	67.00	6.00
6.005	GT106.2357.015.47.60.R	6.00	0.15	23	8	2.70	5.70	0.30	47.00	72.00	6.00
6.006	GT106.2357.015.52.60.R	6.00	0.15	23	8	2.70	5.70	0.30	52.00	77.00	6.00
6.007	GT106.2357.030.27.60.R	6.00	0.30	23	8	2.70	5.70	0.30	27.00	52.00	6.00
6.008	GT106.2357.030.32.60.R	6.00	0.30	23	8	2.70	5.70	0.30	32.00	57.00	6.00
6.009	GT106.2357.030.37.60.R	6.00	0.30	23	8	2.70	5.70	0.30	37.00	62.00	6.00
6.010	GT106.2357.030.42.60.R	6.00	0.30	23	8	2.70	5.70	0.30	42.00	67.00	6.00
6.011	GT106.2357.030.47.60.R	6.00	0.30	23	8	2.70	5.70	0.30	47.00	72.00	6.00
6.012	GT106.2357.030.52.60.R	6.00	0.30	23	8	2.70	5.70	0.30	52.00	77.00	6.00
6.013	GT106.2357.015.12.60.R	6.00	0.15	23	8	2.70	5.70	0.30	12.00	37.00	6.00
6.014	GT106.2357.015.17.60.R	6.00	0.15	23	8	2.70	5.70	0.30	17.00	42.00	6.00
6.015	GT106.2357.015.22.60.R	6.00	0.15	23	8	2.70	5.70	0.30	22.00	47.00	6.00
6.016	GT106.2357.030.12.60.R	6.00	0.30	23	8	2.70	5.70	0.30	12.00	37.00	6.00
6.017	GT106.2357.030.17.60.R	6.00	0.30	23	8	2.70	5.70	0.30	17.00	42.00	6.00
6.018	GT106.2357.030.22.60.R	6.00	0.30	23	8	2.70	5.70	0.30	22.00	47.00	6.00
6.019	GT106.2357.005.12.60.R	6.00	0.05	23	8	2.70	5.70	0.30	12.00	37.00	6.00
6.020	GT106.2357.005.17.60.R	6.00	0.05	23	8	2.70	5.70	0.30	17.00	42.00	6.00
6.021	GT106.2357.005.22.60.R	6.00	0.05	23	8	2.70	5.70	0.30	22.00	47.00	6.00
6.022	GT106.2357.005.27.60.R	6.00	0.05	23	8	2.70	5.70	0.30	27.00	52.00	6.00
6.023	GT106.2357.005.32.60.R	6.00	0.05	23	8	2.70	5.70	0.30	32.00	57.00	6.00
6.024	GT106.2357.005.37.60.R	6.00	0.05	23	8	2.70	5.70	0.30	37.00	62.00	6.00
6.025	GT106.2357.005.42.60.R	6.00	0.05	23	8	2.70	5.70	0.30	42.00	67.00	6.00
6.026	GT106.2357.005.47.60.R	6.00	0.05	23	8	2.70	5.70	0.30	47.00	72.00	6.00
6.027	GT106.2357.005.52.60.R	6.00	0.05	23	8	2.70	5.70	0.30	52.00	77.00	6.00
6.028	GT106.2357.010.12.60.R	6.00	0.10	23	8	2.70	5.70	0.30	12.00	37.00	6.00
6.029	GT106.2357.010.17.60.R	6.00	0.10	23	8	2.70	5.70	0.30	17.00	42.00	6.00
6.030	GT106.2357.010.22.60.R	6.00	0.10	23	8	2.70	5.70	0.30	22.00	47.00	6.00
6.031	GT106.2357.010.27.60.R	6.00	0.10	23	8	2.70	5.70	0.30	27.00	52.00	6.00
6.032	GT106.2357.010.32.60.R	6.00	0.10	23	8	2.70	5.70	0.30	32.00	57.00	6.00
6.033	GT106.2357.010.37.60.R	6.00	0.10	23	8	2.70	5.70	0.30	37.00	62.00	6.00
6.034	GT106.2357.010.42.60.R	6.00	0.10	23	8	2.70	5.70	0.30	42.00	67.00	6.00
6.035	GT106.2357.010.47.60.R	6.00	0.10	23	8	2.70	5.70	0.30	47.00	72.00	6.00
6.036	GT106.2357.010.52.60.R	6.00	0.10	23	8	2.70	5.70	0.30	52.00	77.00	6.00

System 106

Series no. **25700** **25702** **25706**Cutting direction   

Code no.	Description	D min	R	W1	W2	f	a	t max	La	Lg	D h6
		mm	mm	°	°	mm	mm	mm	mm	mm	mm
6.037	GT106.2357.020.12.60.R	6.00	0.20	23	8	2.70	5.70	0.30	12.00	37.00	6.00
6.038	GT106.2357.020.17.60.R	6.00	0.20	23	8	2.70	5.70	0.30	17.00	42.00	6.00
6.039	GT106.2357.020.22.60.R	6.00	0.20	23	8	2.70	5.70	0.30	22.00	47.00	6.00
6.040	GT106.2357.020.27.60.R	6.00	0.20	23	8	2.70	5.70	0.30	27.00	52.00	6.00
6.041	GT106.2357.020.32.60.R	6.00	0.20	23	8	2.70	5.70	0.30	32.00	57.00	6.00
6.042	GT106.2357.020.37.60.R	6.00	0.20	23	8	2.70	5.70	0.30	37.00	62.00	6.00
6.043	GT106.2357.020.42.60.R	6.00	0.20	23	8	2.70	5.70	0.30	42.00	67.00	6.00
6.044	GT106.2357.020.47.60.R	6.00	0.20	23	8	2.70	5.70	0.30	47.00	72.00	6.00
6.045	GT106.2357.020.52.60.R	6.00	0.20	23	8	2.70	5.70	0.30	52.00	77.00	6.00
6.046	GT106.2357.025.12.60.R	6.00	0.25	23	8	2.70	5.70	0.30	12.00	37.00	6.00
6.047	GT106.2357.025.17.60.R	6.00	0.25	23	8	2.70	5.70	0.30	17.00	42.00	6.00
6.048	GT106.2357.025.22.60.R	6.00	0.25	23	8	2.70	5.70	0.30	22.00	47.00	6.00
6.049	GT106.2357.025.27.60.R	6.00	0.25	23	8	2.70	5.70	0.30	27.00	52.00	6.00
6.050	GT106.2357.025.32.60.R	6.00	0.25	23	8	2.70	5.70	0.30	32.00	57.00	6.00
6.051	GT106.2357.025.37.60.R	6.00	0.25	23	8	2.70	5.70	0.30	37.00	62.00	6.00
6.052	GT106.2357.025.42.60.R	6.00	0.25	23	8	2.70	5.70	0.30	42.00	67.00	6.00
6.053	GT106.2357.025.47.60.R	6.00	0.25	23	8	2.70	5.70	0.30	47.00	72.00	6.00
6.054	GT106.2357.025.52.60.R	6.00	0.25	23	8	2.70	5.70	0.30	52.00	77.00	6.00

Series no. **25701** **25703** **25707**
 Cutting direction   

Code no.	Description	D min	R	W1	W2	f	a	t max	La	Lg	D h6
		mm	mm	°	°	mm	mm	mm	mm	mm	mm
6.001	GT106.2357.015.27.60.L	6.00	0.15	23	8	2.70	5.70	0.30	27.00	52.00	6.00
6.002	GT106.2357.015.32.60.L	6.00	0.15	23	8	2.70	5.70	0.30	32.00	57.00	6.00
6.003	GT106.2357.015.37.60.L	6.00	0.15	23	8	2.70	5.70	0.30	37.00	62.00	6.00
6.004	GT106.2357.015.42.60.L	6.00	0.15	23	8	2.70	5.70	0.30	42.00	67.00	6.00
6.005	GT106.2357.015.47.60.L	6.00	0.15	23	8	2.70	5.70	0.30	47.00	72.00	6.00
6.006	GT106.2357.015.52.60.L	6.00	0.15	23	8	2.70	5.70	0.30	52.00	77.00	6.00
6.007	GT106.2357.030.27.60.L	6.00	0.30	23	8	2.70	5.70	0.30	27.00	52.00	6.00
6.008	GT106.2357.030.32.60.L	6.00	0.30	23	8	2.70	5.70	0.30	32.00	57.00	6.00
6.009	GT106.2357.030.37.60.L	6.00	0.30	23	8	2.70	5.70	0.30	37.00	62.00	6.00
6.010	GT106.2357.030.42.60.L	6.00	0.30	23	8	2.70	5.70	0.30	42.00	67.00	6.00
6.011	GT106.2357.030.47.60.L	6.00	0.30	23	8	2.70	5.70	0.30	47.00	72.00	6.00
6.012	GT106.2357.030.52.60.L	6.00	0.30	23	8	2.70	5.70	0.30	52.00	77.00	6.00
6.013	GT106.2357.015.12.60.L	6.00	0.15	23	8	2.70	5.70	0.30	12.00	37.00	6.00
6.014	GT106.2357.015.17.60.L	6.00	0.15	23	8	2.70	5.70	0.30	17.00	42.00	6.00
6.015	GT106.2357.015.22.60.L	6.00	0.15	23	8	2.70	5.70	0.30	22.00	47.00	6.00
6.016	GT106.2357.030.12.60.L	6.00	0.30	23	8	2.70	5.70	0.30	12.00	37.00	6.00
6.017	GT106.2357.030.17.60.L	6.00	0.30	23	8	2.70	5.70	0.30	17.00	42.00	6.00
6.018	GT106.2357.030.22.60.L	6.00	0.30	23	8	2.70	5.70	0.30	22.00	47.00	6.00
6.019	GT106.2357.005.12.60.L	6.00	0.05	23	8	2.70	5.70	0.30	12.00	37.00	6.00
6.020	GT106.2357.005.17.60.L	6.00	0.05	23	8	2.70	5.70	0.30	17.00	42.00	6.00
6.021	GT106.2357.005.22.60.L	6.00	0.05	23	8	2.70	5.70	0.30	22.00	47.00	6.00
6.022	GT106.2357.005.27.60.L	6.00	0.05	23	8	2.70	5.70	0.30	27.00	52.00	6.00
6.023	GT106.2357.005.32.60.L	6.00	0.05	23	8	2.70	5.70	0.30	32.00	57.00	6.00
6.024	GT106.2357.005.37.60.L	6.00	0.05	23	8	2.70	5.70	0.30	37.00	62.00	6.00
6.025	GT106.2357.005.42.60.L	6.00	0.05	23	8	2.70	5.70	0.30	42.00	67.00	6.00
6.026	GT106.2357.005.47.60.L	6.00	0.05	23	8	2.70	5.70	0.30	47.00	72.00	6.00
6.027	GT106.2357.005.52.60.L	6.00	0.05	23	8	2.70	5.70	0.30	52.00	77.00	6.00
6.028	GT106.2357.010.12.60.L	6.00	0.10	23	8	2.70	5.70	0.30	12.00	37.00	6.00
6.029	GT106.2357.010.17.60.L	6.00	0.10	23	8	2.70	5.70	0.30	17.00	42.00	6.00
6.030	GT106.2357.010.22.60.L	6.00	0.10	23	8	2.70	5.70	0.30	22.00	47.00	6.00
6.031	GT106.2357.010.27.60.L	6.00	0.10	23	8	2.70	5.70	0.30	27.00	52.00	6.00
6.032	GT106.2357.010.32.60.L	6.00	0.10	23	8	2.70	5.70	0.30	32.00	57.00	6.00
6.033	GT106.2357.010.37.60.L	6.00	0.10	23	8	2.70	5.70	0.30	37.00	62.00	6.00
6.034	GT106.2357.010.42.60.L	6.00	0.10	23	8	2.70	5.70	0.30	42.00	67.00	6.00
6.035	GT106.2357.010.47.60.L	6.00	0.10	23	8	2.70	5.70	0.30	47.00	72.00	6.00
6.036	GT106.2357.010.52.60.L	6.00	0.10	23	8	2.70	5.70	0.30	52.00	77.00	6.00
6.037	GT106.2357.020.12.60.L	6.00	0.20	23	8	2.70	5.70	0.30	12.00	37.00	6.00
6.038	GT106.2357.020.17.60.L	6.00	0.20	23	8	2.70	5.70	0.30	17.00	42.00	6.00
6.039	GT106.2357.020.22.60.L	6.00	0.20	23	8	2.70	5.70	0.30	22.00	47.00	6.00
6.040	GT106.2357.020.27.60.L	6.00	0.20	23	8	2.70	5.70	0.30	27.00	52.00	6.00
6.041	GT106.2357.020.32.60.L	6.00	0.20	23	8	2.70	5.70	0.30	32.00	57.00	6.00
6.042	GT106.2357.020.37.60.L	6.00	0.20	23	8	2.70	5.70	0.30	37.00	62.00	6.00
6.043	GT106.2357.020.42.60.L	6.00	0.20	23	8	2.70	5.70	0.30	42.00	67.00	6.00
6.044	GT106.2357.020.47.60.L	6.00	0.20	23	8	2.70	5.70	0.30	47.00	72.00	6.00
6.045	GT106.2357.020.52.60.L	6.00	0.20	23	8	2.70	5.70	0.30	52.00	77.00	6.00
6.046	GT106.2357.025.12.60.L	6.00	0.25	23	8	2.70	5.70	0.30	12.00	37.00	6.00
6.047	GT106.2357.025.17.60.L	6.00	0.25	23	8	2.70	5.70	0.30	17.00	42.00	6.00
6.048	GT106.2357.025.22.60.L	6.00	0.25	23	8	2.70	5.70	0.30	22.00	47.00	6.00
6.049	GT106.2357.025.27.60.L	6.00	0.25	23	8	2.70	5.70	0.30	27.00	52.00	6.00
6.050	GT106.2357.025.32.60.L	6.00	0.25	23	8	2.70	5.70	0.30	32.00	57.00	6.00
6.051	GT106.2357.025.37.60.L	6.00	0.25	23	8	2.70	5.70	0.30	37.00	62.00	6.00
6.052	GT106.2357.025.42.60.L	6.00	0.25	23	8	2.70	5.70	0.30	42.00	67.00	6.00
6.053	GT106.2357.025.47.60.L	6.00	0.25	23	8	2.70	5.70	0.30	47.00	72.00	6.00
6.054	GT106.2357.025.52.60.L	6.00	0.25	23	8	2.70	5.70	0.30	52.00	77.00	6.00



Cutting insert for boring out and profiling

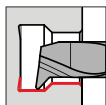

• radial free 47°

for tool holders type GB106 see from page 62

Cutting data page 148

System 106

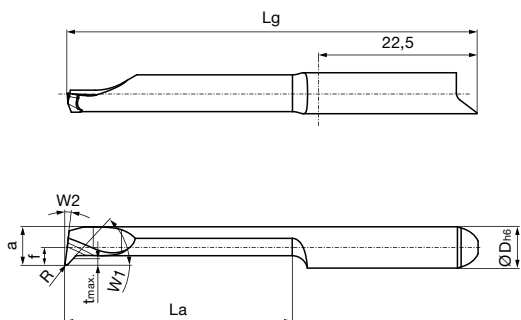

Right hand version shown
Left hand version mirror image

Tool material	Solid carbide		
	GT 106	GT 106	GT 106
Type			
Surface			
	TiN	nano-A	bright

Series no. **25708** **25710** **25714**

Cutting direction

Code no.	Description	D min	R	W1	W2	f	a	t max	La	Lg	D h6
		mm	mm	°	°	mm	mm	mm	mm	mm	mm
6.019	GT106.4757.005.12.60.R	6.00	0.05	47	8	2.70	5.70	0.60	12.00	37.00	6.00
6.020	GT106.4757.005.17.60.R	6.00	0.05	47	8	2.70	5.70	0.60	17.00	42.00	6.00
6.021	GT106.4757.005.22.60.R	6.00	0.05	47	8	2.70	5.70	0.60	22.00	47.00	6.00
6.022	GT106.4757.005.27.60.R	6.00	0.05	47	8	2.70	5.70	0.60	27.00	52.00	6.00
6.023	GT106.4757.005.32.60.R	6.00	0.05	47	8	2.70	5.70	0.60	32.00	57.00	6.00
6.024	GT106.4757.005.37.60.R	6.00	0.05	47	8	2.70	5.70	0.60	37.00	62.00	6.00
6.025	GT106.4757.005.42.60.R	6.00	0.05	47	8	2.70	5.70	0.60	42.00	67.00	6.00
6.026	GT106.4757.005.47.60.R	6.00	0.05	47	8	2.70	5.70	0.60	47.00	72.00	6.00
6.027	GT106.4757.005.52.60.R	6.00	0.05	47	8	2.70	5.70	0.60	52.00	77.00	6.00
6.028	GT106.4757.010.12.60.R	6.00	0.10	47	8	2.70	5.70	0.60	12.00	37.00	6.00
6.029	GT106.4757.010.17.60.R	6.00	0.10	47	8	2.70	5.70	0.60	17.00	42.00	6.00
6.030	GT106.4757.010.22.60.R	6.00	0.10	47	8	2.70	5.70	0.60	22.00	47.00	6.00
6.031	GT106.4757.010.27.60.R	6.00	0.10	47	8	2.70	5.70	0.60	27.00	52.00	6.00
6.032	GT106.4757.010.32.60.R	6.00	0.10	47	8	2.70	5.70	0.60	32.00	57.00	6.00
6.033	GT106.4757.010.37.60.R	6.00	0.10	47	8	2.70	5.70	0.60	37.00	62.00	6.00
6.034	GT106.4757.010.42.60.R	6.00	0.10	47	8	2.70	5.70	0.60	42.00	67.00	6.00
6.035	GT106.4757.010.47.60.R	6.00	0.10	47	8	2.70	5.70	0.60	47.00	72.00	6.00
6.036	GT106.4757.010.52.60.R	6.00	0.10	47	8	2.70	5.70	0.60	52.00	77.00	6.00
6.013	GT106.4757.015.12.60.R	6.00	0.15	47	8	2.70	5.70	0.60	12.00	37.00	6.00
6.014	GT106.4757.015.17.60.R	6.00	0.15	47	8	2.70	5.70	0.60	17.00	42.00	6.00
6.015	GT106.4757.015.22.60.R	6.00	0.15	47	8	2.70	5.70	0.60	22.00	47.00	6.00
6.001	GT106.4757.015.27.60.R	6.00	0.15	47	8	2.70	5.70	0.60	27.00	52.00	6.00
6.002	GT106.4757.015.32.60.R	6.00	0.15	47	8	2.70	5.70	0.60	32.00	57.00	6.00
6.003	GT106.4757.015.37.60.R	6.00	0.15	47	8	2.70	5.70	0.60	37.00	62.00	6.00
6.004	GT106.4757.015.42.60.R	6.00	0.15	47	8	2.70	5.70	0.60	42.00	67.00	6.00
6.005	GT106.4757.015.47.60.R	6.00	0.15	47	8	2.70	5.70	0.60	47.00	72.00	6.00
6.006	GT106.4757.015.52.60.R	6.00	0.15	47	8	2.70	5.70	0.60	52.00	77.00	6.00
6.037	GT106.4757.020.12.60.R	6.00	0.20	47	8	2.70	5.70	0.60	12.00	37.00	6.00
6.038	GT106.4757.020.17.60.R	6.00	0.20	47	8	2.70	5.70	0.60	17.00	42.00	6.00
6.039	GT106.4757.020.22.60.R	6.00	0.20	47	8	2.70	5.70	0.60	22.00	47.00	6.00
6.040	GT106.4757.020.27.60.R	6.00	0.20	47	8	2.70	5.70	0.60	27.00	52.00	6.00
6.041	GT106.4757.020.32.60.R	6.00	0.20	47	8	2.70	5.70	0.60	32.00	57.00	6.00
6.042	GT106.4757.020.37.60.R	6.00	0.20	47	8	2.70	5.70	0.60	37.00	62.00	6.00
6.043	GT106.4757.020.42.60.R	6.00	0.20	47	8	2.70	5.70	0.60	42.00	67.00	6.00
6.044	GT106.4757.020.47.60.R	6.00	0.20	47	8	2.70	5.70	0.60	47.00	72.00	6.00
6.045	GT106.4757.020.52.60.R	6.00	0.20	47	8	2.70	5.70	0.60	52.00	77.00	6.00
6.016	GT106.4757.030.12.60.R	6.00	0.30	47	8	2.70	5.70	0.60	12.00	37.00	6.00



		Series no.		25708	25710	25714						
		Cutting direction										
Code no.	Description	D min	R	W1	W2	f	a	t max	La	Lg	D h6	
		mm	mm	°	°	mm	mm	mm	mm	mm	mm	
6.017	GT106.4757.030.17.60.R	6.00	0.30	47	8	2.70	5.70	0.60	17.00	42.00	6.00	
6.018	GT106.4757.030.22.60.R	6.00	0.30	47	8	2.70	5.70	0.60	22.00	47.00	6.00	
6.007	GT106.4757.030.27.60.R	6.00	0.30	47	8	2.70	5.70	0.60	27.00	52.00	6.00	
6.008	GT106.4757.030.32.60.R	6.00	0.30	47	8	2.70	5.70	0.60	32.00	57.00	6.00	
6.009	GT106.4757.030.37.60.R	6.00	0.30	47	8	2.70	5.70	0.60	37.00	62.00	6.00	
6.010	GT106.4757.030.42.60.R	6.00	0.30	47	8	2.70	5.70	0.60	42.00	67.00	6.00	
6.011	GT106.4757.030.47.60.R	6.00	0.30	47	8	2.70	5.70	0.60	47.00	72.00	6.00	
6.012	GT106.4757.030.52.60.R	6.00	0.30	47	8	2.70	5.70	0.60	52.00	77.00	6.00	

		Series no.		25709	25711	25715						
		Cutting direction										
Code no.	Description	D min	R	W1	W2	f	a	t max	La	Lg	D h6	
		mm	mm	°	°	mm	mm	mm	mm	mm	mm	
6.019	GT106.4757.005.12.60.L	6.00	0.05	47	8	2.70	5.70	0.60	12.00	37.00	6.00	
6.020	GT106.4757.005.17.60.L	6.00	0.05	47	8	2.70	5.70	0.60	17.00	42.00	6.00	
6.021	GT106.4757.005.22.60.L	6.00	0.05	47	8	2.70	5.70	0.60	22.00	47.00	6.00	
6.022	GT106.4757.005.27.60.L	6.00	0.05	47	8	2.70	5.70	0.60	27.00	52.00	6.00	
6.023	GT106.4757.005.32.60.L	6.00	0.05	47	8	2.70	5.70	0.60	32.00	57.00	6.00	
6.024	GT106.4757.005.37.60.L	6.00	0.05	47	8	2.70	5.70	0.60	37.00	62.00	6.00	
6.025	GT106.4757.005.42.60.L	6.00	0.05	47	8	2.70	5.70	0.60	42.00	67.00	6.00	
6.026	GT106.4757.005.47.60.L	6.00	0.05	47	8	2.70	5.70	0.60	47.00	72.00	6.00	
6.027	GT106.4757.005.52.60.L	6.00	0.05	47	8	2.70	5.70	0.60	52.00	77.00	6.00	
6.028	GT106.4757.010.12.60.L	6.00	0.10	47	8	2.70	5.70	0.60	12.00	37.00	6.00	
6.029	GT106.4757.010.17.60.L	6.00	0.10	47	8	2.70	5.70	0.60	17.00	42.00	6.00	
6.030	GT106.4757.010.22.60.L	6.00	0.10	47	8	2.70	5.70	0.60	22.00	47.00	6.00	
6.031	GT106.4757.010.27.60.L	6.00	0.10	47	8	2.70	5.70	0.60	27.00	52.00	6.00	
6.032	GT106.4757.010.32.60.L	6.00	0.10	47	8	2.70	5.70	0.60	32.00	57.00	6.00	
6.033	GT106.4757.010.37.60.L	6.00	0.10	47	8	2.70	5.70	0.60	37.00	62.00	6.00	
6.034	GT106.4757.010.42.60.L	6.00	0.10	47	8	2.70	5.70	0.60	42.00	67.00	6.00	
6.035	GT106.4757.010.47.60.L	6.00	0.10	47	8	2.70	5.70	0.60	47.00	72.00	6.00	
6.036	GT106.4757.010.52.60.L	6.00	0.10	47	8	2.70	5.70	0.60	52.00	77.00	6.00	
6.013	GT106.4757.015.12.60.L	6.00	0.15	47	8	2.70	5.70	0.60	12.00	37.00	6.00	
6.014	GT106.4757.015.17.60.L	6.00	0.15	47	8	2.70	5.70	0.60	17.00	42.00	6.00	
6.015	GT106.4757.015.22.60.L	6.00	0.15	47	8	2.70	5.70	0.60	22.00	47.00	6.00	
6.001	GT106.4757.015.27.60.L	6.00	0.15	47	8	2.70	5.70	0.60	27.00	52.00	6.00	
6.002	GT106.4757.015.32.60.L	6.00	0.15	47	8	2.70	5.70	0.60	32.00	57.00	6.00	
6.003	GT106.4757.015.37.60.L	6.00	0.15	47	8	2.70	5.70	0.60	37.00	62.00	6.00	
6.004	GT106.4757.015.42.60.L	6.00	0.15	47	8	2.70	5.70	0.60	42.00	67.00	6.00	
6.005	GT106.4757.015.47.60.L	6.00	0.15	47	8	2.70	5.70	0.60	47.00	72.00	6.00	
6.006	GT106.4757.015.52.60.L	6.00	0.15	47	8	2.70	5.70	0.60	52.00	77.00	6.00	
6.037	GT106.4757.020.12.60.L	6.00	0.20	47	8	2.70	5.70	0.60	12.00	37.00	6.00	
6.038	GT106.4757.020.17.60.L	6.00	0.20	47	8	2.70	5.70	0.60	17.00	42.00	6.00	
6.039	GT106.4757.020.22.60.L	6.00	0.20	47	8	2.70	5.70	0.60	22.00	47.00	6.00	
6.040	GT106.4757.020.27.60.L	6.00	0.20	47	8	2.70	5.70	0.60	27.00	52.00	6.00	
6.041	GT106.4757.020.32.60.L	6.00	0.20	47	8	2.70	5.70	0.60	32.00	57.00	6.00	
6.042	GT106.4757.020.37.60.L	6.00	0.20	47	8	2.70	5.70	0.60	37.00	62.00	6.00	
6.043	GT106.4757.020.42.60.L	6.00	0.20	47	8	2.70	5.70	0.60	42.00	67.00	6.00	
6.044	GT106.4757.020.47.60.L	6.00	0.20	47	8	2.70	5.70	0.60	47.00	72.00	6.00	
6.045	GT106.4757.020.52.60.L	6.00	0.20	47	8	2.70	5.70	0.60	52.00	77.00	6.00	
6.016	GT106.4757.030.12.60.L	6.00	0.30	47	8	2.70	5.70	0.60	12.00	37.00	6.00	
6.017	GT106.4757.030.17.60.L	6.00	0.30	47	8	2.70	5.70	0.60	17.00	42.00	6.00	
6.018	GT106.4757.030.22.60.L	6.00	0.30	47	8	2.70	5.70	0.60	22.00	47.00	6.00	
6.007	GT106.4757.030.27.60.L	6.00	0.30	47	8	2.70	5.70	0.60	27.00	52.00	6.00	
6.008	GT106.4757.030.32.60.L	6.00	0.30	47	8	2.70	5.70	0.60	32.00	57.00	6.00	
6.009	GT106.4757.030.37.60.L	6.00	0.30	47	8	2.70	5.70	0.60	37.00	62.00	6.00	
6.010	GT106.4757.030.42.60.L	6.00	0.30	47	8	2.70	5.70	0.60	42.00	67.00	6.00	
6.011	GT106.4757.030.47.60.L	6.00	0.30	47	8	2.70	5.70	0.60	47.00	72.00	6.00	
6.012	GT106.4757.030.52.60.L	6.00	0.30	47	8	2.70	5.70	0.60	52.00	77.00	6.00	

System 106



Cutting insert for boring out and profiling

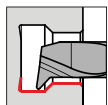

- radial free 47°, tmax 2

for tool holders type GB106 see from page 62

Cutting data page 148

System 106

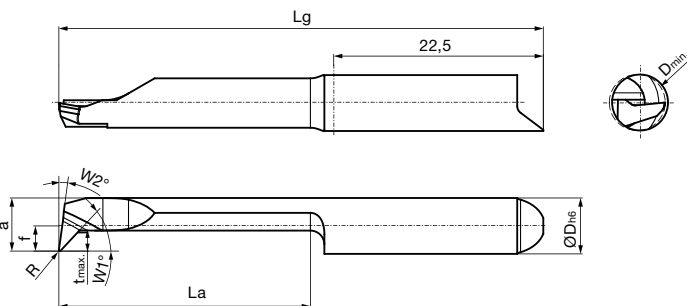

Right hand version shown
Left hand version mirror image

Series no. **25516** **25518** **25522**

Cutting direction

Code no.	Description	D min	R	W1	W2	f	a	t max	La	Lg	D h6
		mm	mm	°	°	mm	mm	mm	mm	mm	mm
6.010	GT106.4757.005.12.60.R.T2	6.00	0.05	47	8	2.70	5.70	2.00	12.00	37.00	6.00
6.020	GT106.4757.005.17.60.R.T2	6.00	0.05	47	8	2.70	5.70	2.00	17.00	42.00	6.00
6.030	GT106.4757.005.22.60.R.T2	6.00	0.05	47	8	2.70	5.70	2.00	22.00	47.00	6.00
6.040	GT106.4757.005.27.60.R.T2	6.00	0.05	47	8	2.70	5.70	2.00	27.00	52.00	6.00
6.050	GT106.4757.005.32.60.R.T2	6.00	0.05	47	8	2.70	5.70	2.00	32.00	57.00	6.00
6.060	GT106.4757.005.37.60.R.T2	6.00	0.05	47	8	2.70	5.70	2.00	37.00	62.00	6.00
6.070	GT106.4757.005.42.60.R.T2	6.00	0.05	47	8	2.70	5.70	2.00	42.00	67.00	6.00
6.080	GT106.4757.005.47.60.R.T2	6.00	0.05	47	8	2.70	5.70	2.00	47.00	72.00	6.00
6.090	GT106.4757.005.52.60.R.T2	6.00	0.05	47	8	2.70	5.70	2.00	52.00	77.00	6.00
6.110	GT106.4757.010.12.60.R.T2	6.00	0.10	47	8	2.70	5.70	2.00	12.00	37.00	6.00
6.120	GT106.4757.010.17.60.R.T2	6.00	0.10	47	8	2.70	5.70	2.00	17.00	42.00	6.00
6.130	GT106.4757.010.22.60.R.T2	6.00	0.10	47	8	2.70	5.70	2.00	22.00	47.00	6.00
6.140	GT106.4757.010.27.60.R.T2	6.00	0.10	47	8	2.70	5.70	2.00	27.00	52.00	6.00
6.150	GT106.4757.010.32.60.R.T2	6.00	0.10	47	8	2.70	5.70	2.00	32.00	57.00	6.00
6.160	GT106.4757.010.37.60.R.T2	6.00	0.10	47	8	2.70	5.70	2.00	37.00	62.00	6.00
6.170	GT106.4757.010.42.60.R.T2	6.00	0.10	47	8	2.70	5.70	2.00	42.00	67.00	6.00
6.180	GT106.4757.010.47.60.R.T2	6.00	0.10	47	8	2.70	5.70	2.00	47.00	72.00	6.00
6.190	GT106.4757.010.52.60.R.T2	6.00	0.10	47	8	2.70	5.70	2.00	52.00	77.00	6.00
6.210	GT106.4757.015.12.60.R.T2	6.00	0.15	47	8	2.70	5.70	2.00	12.00	37.00	6.00
6.220	GT106.4757.015.17.60.R.T2	6.00	0.15	47	8	2.70	5.70	2.00	17.00	42.00	6.00
6.230	GT106.4757.015.22.60.R.T2	6.00	0.15	47	8	2.70	5.70	2.00	22.00	47.00	6.00
6.240	GT106.4757.015.27.60.R.T2	6.00	0.15	47	8	2.70	5.70	2.00	27.00	52.00	6.00
6.250	GT106.4757.015.32.60.R.T2	6.00	0.15	47	8	2.70	5.70	2.00	32.00	57.00	6.00
6.260	GT106.4757.015.37.60.R.T2	6.00	0.15	47	8	2.70	5.70	2.00	37.00	62.00	6.00
6.270	GT106.4757.015.42.60.R.T2	6.00	0.15	47	8	2.70	5.70	2.00	42.00	67.00	6.00
6.280	GT106.4757.015.47.60.R.T2	6.00	0.15	47	8	2.70	5.70	2.00	47.00	72.00	6.00
6.290	GT106.4757.015.52.60.R.T2	6.00	0.15	47	8	2.70	5.70	2.00	52.00	77.00	6.00
6.310	GT106.4757.020.12.60.R.T2	6.00	0.20	47	8	2.70	5.70	2.00	12.00	37.00	6.00
6.320	GT106.4757.020.17.60.R.T2	6.00	0.20	47	8	2.70	5.70	2.00	17.00	42.00	6.00
6.330	GT106.4757.020.22.60.R.T2	6.00	0.20	47	8	2.70	5.70	2.00	22.00	47.00	6.00
6.340	GT106.4757.020.27.60.R.T2	6.00	0.20	47	8	2.70	5.70	2.00	27.00	52.00	6.00
6.350	GT106.4757.020.32.60.R.T2	6.00	0.20	47	8	2.70	5.70	2.00	32.00	57.00	6.00
6.360	GT106.4757.020.37.60.R.T2	6.00	0.20	47	8	2.70	5.70	2.00	37.00	62.00	6.00
6.370	GT106.4757.020.42.60.R.T2	6.00	0.20	47	8	2.70	5.70	2.00	42.00	67.00	6.00
6.380	GT106.4757.020.47.60.R.T2	6.00	0.20	47	8	2.70	5.70	2.00	47.00	72.00	6.00
6.390	GT106.4757.020.52.60.R.T2	6.00	0.20	47	8	2.70	5.70	2.00	52.00	77.00	6.00
6.410	GT106.4757.030.12.60.R.T2	6.00	0.30	47	8	2.70	5.70	2.00	12.00	37.00	6.00

Series no. **25516** **25518** **25522**Cutting direction   

Code no.	Description	D min	R	W1	W2	f	a	t max	La	Lg	D h6
		mm	mm	°	°	mm	mm	mm	mm	mm	mm
6.420	GT106.4757.030.17.60.R.T2	6.00	0.30	47	8	2.70	5.70	2.00	17.00	42.00	6.00
6.430	GT106.4757.030.22.60.R.T2	6.00	0.30	47	8	2.70	5.70	2.00	22.00	47.00	6.00
6.440	GT106.4757.030.27.60.R.T2	6.00	0.30	47	8	2.70	5.70	2.00	27.00	52.00	6.00
6.450	GT106.4757.030.32.60.R.T2	6.00	0.30	47	8	2.70	5.70	2.00	32.00	57.00	6.00
6.460	GT106.4757.030.37.60.R.T2	6.00	0.30	47	8	2.70	5.70	2.00	37.00	62.00	6.00
6.470	GT106.4757.030.42.60.R.T2	6.00	0.30	47	8	2.70	5.70	2.00	42.00	67.00	6.00
6.480	GT106.4757.030.47.60.R.T2	6.00	0.30	47	8	2.70	5.70	2.00	47.00	72.00	6.00
6.490	GT106.4757.030.52.60.R.T2	6.00	0.30	47	8	2.70	5.70	2.00	52.00	77.00	6.00

Series no. **25517** **25519** **25523**Cutting direction   

Code no.	Description	D min	R	W1	W2	f	a	t max	La	Lg	D h6
		mm	mm	°	°	mm	mm	mm	mm	mm	mm
6.010	GT106.4757.005.12.60.L.T2	6.00	0.05	47	8	2.70	5.70	2.00	12.00	37.00	6.00
6.020	GT106.4757.005.17.60.L.T2	6.00	0.05	47	8	2.70	5.70	2.00	17.00	42.00	6.00
6.030	GT106.4757.005.22.60.L.T2	6.00	0.05	47	8	2.70	5.70	2.00	22.00	47.00	6.00
6.040	GT106.4757.005.27.60.L.T2	6.00	0.05	47	8	2.70	5.70	2.00	27.00	52.00	6.00
6.050	GT106.4757.005.32.60.L.T2	6.00	0.05	47	8	2.70	5.70	2.00	32.00	57.00	6.00
6.060	GT106.4757.005.37.60.L.T2	6.00	0.05	47	8	2.70	5.70	2.00	37.00	62.00	6.00
6.070	GT106.4757.005.42.60.L.T2	6.00	0.05	47	8	2.70	5.70	2.00	42.00	67.00	6.00
6.080	GT106.4757.005.47.60.L.T2	6.00	0.05	47	8	2.70	5.70	2.00	47.00	72.00	6.00
6.090	GT106.4757.005.52.60.L.T2	6.00	0.05	47	8	2.70	5.70	2.00	52.00	77.00	6.00
6.110	GT106.4757.010.12.60.L.T2	6.00	0.10	47	8	2.70	5.70	2.00	12.00	37.00	6.00
6.120	GT106.4757.010.17.60.L.T2	6.00	0.10	47	8	2.70	5.70	2.00	17.00	42.00	6.00
6.130	GT106.4757.010.22.60.L.T2	6.00	0.10	47	8	2.70	5.70	2.00	22.00	47.00	6.00
6.140	GT106.4757.010.27.60.L.T2	6.00	0.10	47	8	2.70	5.70	2.00	27.00	52.00	6.00
6.150	GT106.4757.010.32.60.L.T2	6.00	0.10	47	8	2.70	5.70	2.00	32.00	57.00	6.00
6.160	GT106.4757.010.37.60.L.T2	6.00	0.10	47	8	2.70	5.70	2.00	37.00	62.00	6.00
6.170	GT106.4757.010.42.60.L.T2	6.00	0.10	47	8	2.70	5.70	2.00	42.00	67.00	6.00
6.180	GT106.4757.010.47.60.L.T2	6.00	0.10	47	8	2.70	5.70	2.00	47.00	72.00	6.00
6.190	GT106.4757.010.52.60.L.T2	6.00	0.10	47	8	2.70	5.70	2.00	52.00	77.00	6.00
6.210	GT106.4757.015.12.60.L.T2	6.00	0.15	47	8	2.70	5.70	2.00	12.00	37.00	6.00
6.220	GT106.4757.015.17.60.L.T2	6.00	0.15	47	8	2.70	5.70	2.00	17.00	42.00	6.00
6.230	GT106.4757.015.22.60.L.T2	6.00	0.15	47	8	2.70	5.70	2.00	22.00	47.00	6.00
6.240	GT106.4757.015.27.60.L.T2	6.00	0.15	47	8	2.70	5.70	2.00	27.00	52.00	6.00
6.250	GT106.4757.015.32.60.L.T2	6.00	0.15	47	8	2.70	5.70	2.00	32.00	57.00	6.00
6.260	GT106.4757.015.37.60.L.T2	6.00	0.15	47	8	2.70	5.70	2.00	37.00	62.00	6.00
6.270	GT106.4757.015.42.60.L.T2	6.00	0.15	47	8	2.70	5.70	2.00	42.00	67.00	6.00
6.280	GT106.4757.015.47.60.L.T2	6.00	0.15	47	8	2.70	5.70	2.00	47.00	72.00	6.00
6.290	GT106.4757.015.52.60.L.T2	6.00	0.15	47	8	2.70	5.70	2.00	52.00	77.00	6.00
6.310	GT106.4757.020.12.60.L.T2	6.00	0.20	47	8	2.70	5.70	2.00	12.00	37.00	6.00
6.320	GT106.4757.020.17.60.L.T2	6.00	0.20	47	8	2.70	5.70	2.00	17.00	42.00	6.00
6.330	GT106.4757.020.22.60.L.T2	6.00	0.20	47	8	2.70	5.70	2.00	22.00	47.00	6.00
6.340	GT106.4757.020.27.60.L.T2	6.00	0.20	47	8	2.70	5.70	2.00	27.00	52.00	6.00
6.350	GT106.4757.020.32.60.L.T2	6.00	0.20	47	8	2.70	5.70	2.00	32.00	57.00	6.00
6.360	GT106.4757.020.37.60.L.T2	6.00	0.20	47	8	2.70	5.70	2.00	37.00	62.00	6.00
6.370	GT106.4757.020.42.60.L.T2	6.00	0.20	47	8	2.70	5.70	2.00	42.00	67.00	6.00
6.380	GT106.4757.020.47.60.L.T2	6.00	0.20	47	8	2.70	5.70	2.00	47.00	72.00	6.00
6.390	GT106.4757.020.52.60.L.T2	6.00	0.20	47	8	2.70	5.70	2.00	52.00	77.00	6.00
6.410	GT106.4757.030.12.60.L.T2	6.00	0.30	47	8	2.70	5.70	2.00	12.00	37.00	6.00
6.420	GT106.4757.030.17.60.L.T2	6.00	0.30	47	8	2.70	5.70	2.00	17.00	42.00	6.00
6.430	GT106.4757.030.22.60.L.T2	6.00	0.30	47	8	2.70	5.70	2.00	22.00	47.00	6.00
6.440	GT106.4757.030.27.60.L.T2	6.00	0.30	47	8	2.70	5.70	2.00	27.00	52.00	6.00
6.450	GT106.4757.030.32.60.L.T2	6.00	0.30	47	8	2.70	5.70	2.00	32.00	57.00	6.00
6.460	GT106.4757.030.37.60.L.T2	6.00	0.30	47	8	2.70	5.70	2.00	37.00	62.00	6.00
6.470	GT106.4757.030.42.60.L.T2	6.00	0.30	47	8	2.70	5.70	2.00	42.00	67.00	6.00
6.480	GT106.4757.030.47.60.L.T2	6.00	0.30	47	8	2.70	5.70	2.00	47.00	72.00	6.00
6.490	GT106.4757.030.52.60.L.T2	6.00	0.30	47	8	2.70	5.70	2.00	52.00	77.00	6.00

System 106



Cutting insert for boring out and profiling

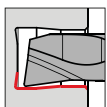

• radial free 8°

for tool holders type GB106 see from page 62

Cutting data page 148

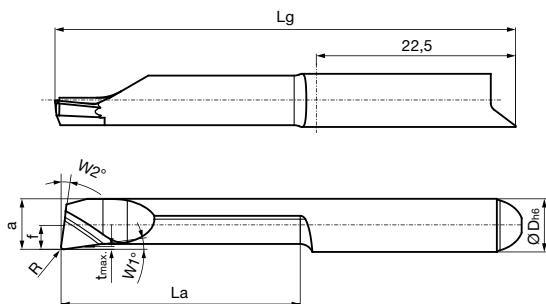

Right hand version shown
Left hand version mirror image



Tool material	Solid carbide		
Type	GT 106	GT 106	GT 106
Surface			
	TiN	nano-A	bright

Series no.	25508	25510	25514
Cutting direction			

Code no.	Description	D min	R	W1	W2	f	a	t max	La	Lg	D h6
		mm	mm	°	°	mm	mm	mm	mm	mm	mm
6.010	GT106.0857.005.12.60.R	6.00	0.05	8	8	2.70	5.70	0.30	12.00	37.00	6.00
6.020	GT106.0857.005.17.60.R	6.00	0.05	8	8	2.70	5.70	0.30	17.00	42.00	6.00
6.030	GT106.0857.005.22.60.R	6.00	0.05	8	8	2.70	5.70	0.30	22.00	47.00	6.00
6.040	GT106.0857.005.27.60.R	6.00	0.05	8	8	2.70	5.70	0.30	27.00	52.00	6.00
6.050	GT106.0857.005.32.60.R	6.00	0.05	8	8	2.70	5.70	0.30	32.00	57.00	6.00
6.060	GT106.0857.005.37.60.R	6.00	0.05	8	8	2.70	5.70	0.30	37.00	62.00	6.00
6.070	GT106.0857.005.42.60.R	6.00	0.05	8	8	2.70	5.70	0.30	42.00	67.00	6.00
6.110	GT106.0857.010.12.60.R	6.00	0.10	8	8	2.70	5.70	0.30	12.00	37.00	6.00
6.120	GT106.0857.010.17.60.R	6.00	0.10	8	8	2.70	5.70	0.30	17.00	42.00	6.00
6.130	GT106.0857.010.22.60.R	6.00	0.10	8	8	2.70	5.70	0.30	22.00	47.00	6.00
6.140	GT106.0857.010.27.60.R	6.00	0.10	8	8	2.70	5.70	0.30	27.00	52.00	6.00
6.150	GT106.0857.010.32.60.R	6.00	0.10	8	8	2.70	5.70	0.30	32.00	57.00	6.00
6.160	GT106.0857.010.37.60.R	6.00	0.10	8	8	2.70	5.70	0.30	37.00	62.00	6.00
6.170	GT106.0857.010.42.60.R	6.00	0.10	8	8	2.70	5.70	0.30	42.00	67.00	6.00
6.210	GT106.0857.015.12.60.R	6.00	0.15	8	8	2.70	5.70	0.30	12.00	37.00	6.00
6.220	GT106.0857.015.17.60.R	6.00	0.15	8	8	2.70	5.70	0.30	17.00	42.00	6.00
6.230	GT106.0857.015.22.60.R	6.00	0.15	8	8	2.70	5.70	0.30	22.00	47.00	6.00
6.240	GT106.0857.015.27.60.R	6.00	0.15	8	8	2.70	5.70	0.30	27.00	52.00	6.00
6.250	GT106.0857.015.32.60.R	6.00	0.15	8	8	2.70	5.70	0.30	32.00	57.00	6.00
6.260	GT106.0857.015.37.60.R	6.00	0.15	8	8	2.70	5.70	0.30	37.00	62.00	6.00
6.270	GT106.0857.015.42.60.R	6.00	0.15	8	8	2.70	5.70	0.30	42.00	67.00	6.00
6.310	GT106.0857.020.12.60.R	6.00	0.20	8	8	2.70	5.70	0.30	12.00	37.00	6.00
6.320	GT106.0857.020.17.60.R	6.00	0.20	8	8	2.70	5.70	0.30	17.00	42.00	6.00
6.330	GT106.0857.020.22.60.R	6.00	0.20	8	8	2.70	5.70	0.30	22.00	47.00	6.00
6.340	GT106.0857.020.27.60.R	6.00	0.20	8	8	2.70	5.70	0.30	27.00	52.00	6.00
6.350	GT106.0857.020.32.60.R	6.00	0.20	8	8	2.70	5.70	0.30	32.00	57.00	6.00
6.360	GT106.0857.020.37.60.R	6.00	0.20	8	8	2.70	5.70	0.30	37.00	62.00	6.00
6.370	GT106.0857.020.42.60.R	6.00	0.20	8	8	2.70	5.70	0.30	42.00	67.00	6.00
6.410	GT106.0857.030.12.60.R	6.00	0.30	8	8	2.70	5.70	0.30	12.00	37.00	6.00
6.420	GT106.0857.030.17.60.R	6.00	0.30	8	8	2.70	5.70	0.30	17.00	42.00	6.00
6.430	GT106.0857.030.22.60.R	6.00	0.30	8	8	2.70	5.70	0.30	22.00	47.00	6.00
6.440	GT106.0857.030.27.60.R	6.00	0.30	8	8	2.70	5.70	0.30	27.00	52.00	6.00
6.450	GT106.0857.030.32.60.R	6.00	0.30	8	8	2.70	5.70	0.30	32.00	57.00	6.00
6.460	GT106.0857.030.37.60.R	6.00	0.30	8	8	2.70	5.70	0.30	37.00	62.00	6.00
6.470	GT106.0857.030.42.60.R	6.00	0.30	8	8	2.70	5.70	0.30	42.00	67.00	6.00

Series no. **25509** **25511** **25515**

Cutting direction   

Code no.	Description	D min	R	W1	W2	f	a	t max	La	Lg	D h6
		mm	mm	°	°	mm	mm	mm	mm	mm	mm
6.010	GT106.0857.005.12.60.L	6.00	0.05	8	8	2.70	5.70	0.30	12.00	37.00	6.00
6.020	GT106.0857.005.17.60.L	6.00	0.05	8	8	2.70	5.70	0.30	17.00	42.00	6.00
6.030	GT106.0857.005.22.60.L	6.00	0.05	8	8	2.70	5.70	0.30	22.00	47.00	6.00
6.040	GT106.0857.005.27.60.L	6.00	0.05	8	8	2.70	5.70	0.30	27.00	52.00	6.00
6.050	GT106.0857.005.32.60.L	6.00	0.05	8	8	2.70	5.70	0.30	32.00	57.00	6.00
6.060	GT106.0857.005.37.60.L	6.00	0.05	8	8	2.70	5.70	0.30	37.00	62.00	6.00
6.070	GT106.0857.005.42.60.L	6.00	0.05	8	8	2.70	5.70	0.30	42.00	67.00	6.00
6.110	GT106.0857.010.12.60.L	6.00	0.10	8	8	2.70	5.70	0.30	12.00	37.00	6.00
6.120	GT106.0857.010.17.60.L	6.00	0.10	8	8	2.70	5.70	0.30	17.00	42.00	6.00
6.130	GT106.0857.010.22.60.L	6.00	0.10	8	8	2.70	5.70	0.30	22.00	47.00	6.00
6.140	GT106.0857.010.27.60.L	6.00	0.10	8	8	2.70	5.70	0.30	27.00	52.00	6.00
6.150	GT106.0857.010.32.60.L	6.00	0.10	8	8	2.70	5.70	0.30	32.00	57.00	6.00
6.160	GT106.0857.010.37.60.L	6.00	0.10	8	8	2.70	5.70	0.30	37.00	62.00	6.00
6.170	GT106.0857.010.42.60.L	6.00	0.10	8	8	2.70	5.70	0.30	42.00	67.00	6.00
6.210	GT106.0857.015.12.60.L	6.00	0.15	8	8	2.70	5.70	0.30	12.00	37.00	6.00
6.220	GT106.0857.015.17.60.L	6.00	0.15	8	8	2.70	5.70	0.30	17.00	42.00	6.00
6.230	GT106.0857.015.22.60.L	6.00	0.15	8	8	2.70	5.70	0.30	22.00	47.00	6.00
6.240	GT106.0857.015.27.60.L	6.00	0.15	8	8	2.70	5.70	0.30	27.00	52.00	6.00
6.250	GT106.0857.015.32.60.L	6.00	0.15	8	8	2.70	5.70	0.30	32.00	57.00	6.00
6.260	GT106.0857.015.37.60.L	6.00	0.15	8	8	2.70	5.70	0.30	37.00	62.00	6.00
6.270	GT106.0857.015.42.60.L	6.00	0.15	8	8	2.70	5.70	0.30	42.00	67.00	6.00
6.310	GT106.0857.020.12.60.L	6.00	0.20	8	8	2.70	5.70	0.30	12.00	37.00	6.00
6.320	GT106.0857.020.17.60.L	6.00	0.20	8	8	2.70	5.70	0.30	17.00	42.00	6.00
6.330	GT106.0857.020.22.60.L	6.00	0.20	8	8	2.70	5.70	0.30	22.00	47.00	6.00
6.340	GT106.0857.020.27.60.L	6.00	0.20	8	8	2.70	5.70	0.30	27.00	52.00	6.00
6.350	GT106.0857.020.32.60.L	6.00	0.20	8	8	2.70	5.70	0.30	32.00	57.00	6.00
6.360	GT106.0857.020.37.60.L	6.00	0.20	8	8	2.70	5.70	0.30	37.00	62.00	6.00
6.370	GT106.0857.020.42.60.L	6.00	0.20	8	8	2.70	5.70	0.30	42.00	67.00	6.00
6.410	GT106.0857.030.12.60.L	6.00	0.30	8	8	2.70	5.70	0.30	12.00	37.00	6.00
6.420	GT106.0857.030.17.60.L	6.00	0.30	8	8	2.70	5.70	0.30	17.00	42.00	6.00
6.430	GT106.0857.030.22.60.L	6.00	0.30	8	8	2.70	5.70	0.30	22.00	47.00	6.00
6.440	GT106.0857.030.27.60.L	6.00	0.30	8	8	2.70	5.70	0.30	27.00	52.00	6.00
6.450	GT106.0857.030.32.60.L	6.00	0.30	8	8	2.70	5.70	0.30	32.00	57.00	6.00
6.460	GT106.0857.030.37.60.L	6.00	0.30	8	8	2.70	5.70	0.30	37.00	62.00	6.00
6.470	GT106.0857.030.42.60.L	6.00	0.30	8	8	2.70	5.70	0.30	42.00	67.00	6.00

System 106



Cutting insert for boring out and profiling

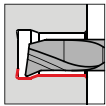

• WIPER-geometry

for tool holders type GB106 see from page 62

Cutting data page 148

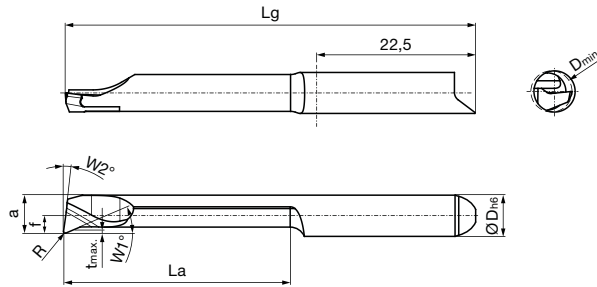

Right hand version shown
Left hand version mirror image

Tool material	Solid carbide			
	Type	GJ 106	GJ 106	GJ 106
Surface				
	TiN	nano-A	bright	



Series no.	25716	25718	25722
Cutting direction			

Code no.	Description	D min	R	W1	W2	f	a	t max	La	Lg	D h6
		mm	mm	°	°	mm	mm	mm	mm	mm	mm
6.019	GJ106.2357.005.12.60.R	6.00	0.05	23	8	2.70	5.70	0.30	12.00	37.00	6.00
6.020	GJ106.2357.005.17.60.R	6.00	0.05	23	8	2.70	5.70	0.30	17.00	42.00	6.00
6.021	GJ106.2357.005.22.60.R	6.00	0.05	23	8	2.70	5.70	0.30	22.00	47.00	6.00
6.022	GJ106.2357.005.27.60.R	6.00	0.05	23	8	2.70	5.70	0.30	27.00	52.00	6.00
6.023	GJ106.2357.005.32.60.R	6.00	0.05	23	8	2.70	5.70	0.30	32.00	57.00	6.00
6.024	GJ106.2357.005.37.60.R	6.00	0.05	23	8	2.70	5.70	0.30	37.00	62.00	6.00
6.025	GJ106.2357.005.42.60.R	6.00	0.05	23	8	2.70	5.70	0.30	42.00	67.00	6.00
6.026	GJ106.2357.005.47.60.R	6.00	0.05	23	8	2.70	5.70	0.30	47.00	72.00	6.00
6.027	GJ106.2357.005.52.60.R	6.00	0.05	23	8	2.70	5.70	0.30	52.00	77.00	6.00
6.013	GJ106.2357.015.12.60.R	6.00	0.15	23	8	2.70	5.70	0.30	12.00	37.00	6.00
6.014	GJ106.2357.015.17.60.R	6.00	0.15	23	8	2.70	5.70	0.30	17.00	42.00	6.00
6.015	GJ106.2357.015.22.60.R	6.00	0.15	23	8	2.70	5.70	0.30	22.00	47.00	6.00
6.001	GJ106.2357.015.27.60.R	6.00	0.15	23	8	2.70	5.70	0.30	27.00	52.00	6.00
6.002	GJ106.2357.015.32.60.R	6.00	0.15	23	8	2.70	5.70	0.30	32.00	57.00	6.00
6.003	GJ106.2357.015.37.60.R	6.00	0.15	23	8	2.70	5.70	0.30	37.00	62.00	6.00
6.004	GJ106.2357.015.42.60.R	6.00	0.15	23	8	2.70	5.70	0.30	42.00	67.00	6.00
6.005	GJ106.2357.015.47.60.R	6.00	0.15	23	8	2.70	5.70	0.30	47.00	72.00	6.00
6.006	GJ106.2357.015.52.60.R	6.00	0.15	23	8	2.70	5.70	0.30	52.00	77.00	6.00
6.028	GJ106.2357.020.12.60.R	6.00	0.20	23	8	2.70	5.70	0.30	12.00	37.00	6.00
6.029	GJ106.2357.020.17.60.R	6.00	0.20	23	8	2.70	5.70	0.30	17.00	42.00	6.00
6.030	GJ106.2357.020.22.60.R	6.00	0.20	23	8	2.70	5.70	0.30	22.00	47.00	6.00
6.031	GJ106.2357.020.27.60.R	6.00	0.20	23	8	2.70	5.70	0.30	27.00	52.00	6.00
6.032	GJ106.2357.020.32.60.R	6.00	0.20	23	8	2.70	5.70	0.30	32.00	57.00	6.00
6.033	GJ106.2357.020.37.60.R	6.00	0.20	23	8	2.70	5.70	0.30	37.00	62.00	6.00
6.034	GJ106.2357.020.42.60.R	6.00	0.20	23	8	2.70	5.70	0.30	42.00	67.00	6.00
6.035	GJ106.2357.020.47.60.R	6.00	0.20	23	8	2.70	5.70	0.30	47.00	72.00	6.00
6.036	GJ106.2357.020.52.60.R	6.00	0.20	23	8	2.70	5.70	0.30	52.00	77.00	6.00
6.016	GJ106.2357.030.12.60.R	6.00	0.30	23	8	2.70	5.70	0.30	12.00	37.00	6.00
6.017	GJ106.2357.030.17.60.R	6.00	0.30	23	8	2.70	5.70	0.30	17.00	42.00	6.00
6.018	GJ106.2357.030.22.60.R	6.00	0.30	23	8	2.70	5.70	0.30	22.00	47.00	6.00
6.007	GJ106.2357.030.27.60.R	6.00	0.30	23	8	2.70	5.70	0.30	27.00	52.00	6.00
6.008	GJ106.2357.030.32.60.R	6.00	0.30	23	8	2.70	5.70	0.30	32.00	57.00	6.00
6.009	GJ106.2357.030.37.60.R	6.00	0.30	23	8	2.70	5.70	0.30	37.00	62.00	6.00
6.010	GJ106.2357.030.42.60.R	6.00	0.30	23	8	2.70	5.70	0.30	42.00	67.00	6.00
6.011	GJ106.2357.030.47.60.R	6.00	0.30	23	8	2.70	5.70	0.30	47.00	72.00	6.00
6.012	GJ106.2357.030.52.60.R	6.00	0.30	23	8	2.70	5.70	0.30	52.00	77.00	6.00

Series no. **25717** **25719** **25723**

Cutting direction



Code no.	Description	D min	R	W1	W2	f	a	t max	La	Lg	D h6
		mm	mm	°	°	mm	mm	mm	mm	mm	mm
6.019	GJ106.2357.005.12.60.L	6.00	0.05	23	8	2.70	5.70	0.30	12.00	37.00	6.00
6.020	GJ106.2357.005.17.60.L	6.00	0.05	23	8	2.70	5.70	0.30	17.00	42.00	6.00
6.021	GJ106.2357.005.22.60.L	6.00	0.05	23	8	2.70	5.70	0.30	22.00	47.00	6.00
6.022	GJ106.2357.005.27.60.L	6.00	0.05	23	8	2.70	5.70	0.30	27.00	52.00	6.00
6.023	GJ106.2357.005.32.60.L	6.00	0.05	23	8	2.70	5.70	0.30	32.00	57.00	6.00
6.024	GJ106.2357.005.37.60.L	6.00	0.05	23	8	2.70	5.70	0.30	37.00	62.00	6.00
6.025	GJ106.2357.005.42.60.L	6.00	0.05	23	8	2.70	5.70	0.30	42.00	67.00	6.00
6.026	GJ106.2357.005.47.60.L	6.00	0.05	23	8	2.70	5.70	0.30	47.00	72.00	6.00
6.027	GJ106.2357.005.52.60.L	6.00	0.05	23	8	2.70	5.70	0.30	52.00	77.00	6.00
6.013	GJ106.2357.015.12.60.L	6.00	0.15	23	8	2.70	5.70	0.30	12.00	37.00	6.00
6.014	GJ106.2357.015.17.60.L	6.00	0.15	23	8	2.70	5.70	0.30	17.00	42.00	6.00
6.015	GJ106.2357.015.22.60.L	6.00	0.15	23	8	2.70	5.70	0.30	22.00	47.00	6.00
6.001	GJ106.2357.015.27.60.L	6.00	0.15	23	8	2.70	5.70	0.30	27.00	52.00	6.00
6.002	GJ106.2357.015.32.60.L	6.00	0.15	23	8	2.70	5.70	0.30	32.00	57.00	6.00
6.003	GJ106.2357.015.37.60.L	6.00	0.15	23	8	2.70	5.70	0.30	37.00	62.00	6.00
6.004	GJ106.2357.015.42.60.L	6.00	0.15	23	8	2.70	5.70	0.30	42.00	67.00	6.00
6.005	GJ106.2357.015.47.60.L	6.00	0.15	23	8	2.70	5.70	0.30	47.00	72.00	6.00
6.006	GJ106.2357.015.52.60.L	6.00	0.15	23	8	2.70	5.70	0.30	52.00	77.00	6.00
6.028	GJ106.2357.020.12.60.L	6.00	0.20	23	8	2.70	5.70	0.30	12.00	37.00	6.00
6.029	GJ106.2357.020.17.60.L	6.00	0.20	23	8	2.70	5.70	0.30	17.00	42.00	6.00
6.030	GJ106.2357.020.22.60.L	6.00	0.20	23	8	2.70	5.70	0.30	22.00	47.00	6.00
6.031	GJ106.2357.020.27.60.L	6.00	0.20	23	8	2.70	5.70	0.30	27.00	52.00	6.00
6.032	GJ106.2357.020.32.60.L	6.00	0.20	23	8	2.70	5.70	0.30	32.00	57.00	6.00
6.033	GJ106.2357.020.37.60.L	6.00	0.20	23	8	2.70	5.70	0.30	37.00	62.00	6.00
6.034	GJ106.2357.020.42.60.L	6.00	0.20	23	8	2.70	5.70	0.30	42.00	67.00	6.00
6.035	GJ106.2357.020.47.60.L	6.00	0.20	23	8	2.70	5.70	0.30	47.00	72.00	6.00
6.036	GJ106.2357.020.52.60.L	6.00	0.20	23	8	2.70	5.70	0.30	52.00	77.00	6.00
6.016	GJ106.2357.030.12.60.L	6.00	0.30	23	8	2.70	5.70	0.30	12.00	37.00	6.00
6.017	GJ106.2357.030.17.60.L	6.00	0.30	23	8	2.70	5.70	0.30	17.00	42.00	6.00
6.018	GJ106.2357.030.22.60.L	6.00	0.30	23	8	2.70	5.70	0.30	22.00	47.00	6.00
6.007	GJ106.2357.030.27.60.L	6.00	0.30	23	8	2.70	5.70	0.30	27.00	52.00	6.00
6.008	GJ106.2357.030.32.60.L	6.00	0.30	23	8	2.70	5.70	0.30	32.00	57.00	6.00
6.009	GJ106.2357.030.37.60.L	6.00	0.30	23	8	2.70	5.70	0.30	37.00	62.00	6.00
6.010	GJ106.2357.030.42.60.L	6.00	0.30	23	8	2.70	5.70	0.30	42.00	67.00	6.00
6.011	GJ106.2357.030.47.60.L	6.00	0.30	23	8	2.70	5.70	0.30	47.00	72.00	6.00
6.012	GJ106.2357.030.52.60.L	6.00	0.30	23	8	2.70	5.70	0.30	52.00	77.00	6.00



Cutting insert for back boring and profiling

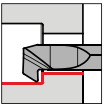

• radial free 32°

for tool holders type GB106 see from page 62

Cutting data page 148

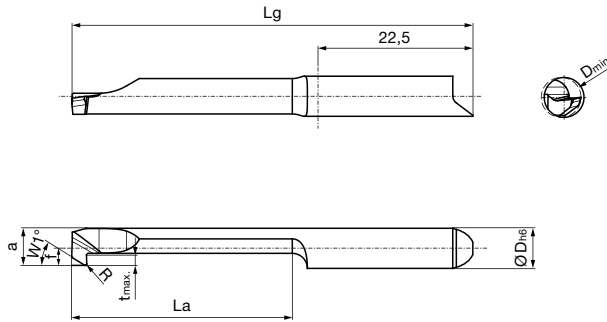

Right hand version shown
Left hand version mirror image

Tool material	Solid carbide			
	Type	GT 106	GT 106	GT 106
Surface	S	a	○	
	TiN	nano-A	bright	



Series no.	25732	25734	25738
Cutting direction	(R)	(R)	(R)

Code no.	Description	D min	R	W1	f	a	t max	La	Lg	D h6
		mm	mm	°	mm	mm	mm	mm	mm	mm
6.013	GT106.3257.020.12.60.R	6.00	0.20	32	2.70	5.70	2.00	12.00	37.00	6.00
6.014	GT106.3257.020.17.60.R	6.00	0.20	32	2.70	5.70	2.00	17.00	42.00	6.00
6.001	GT106.3257.020.22.60.R	6.00	0.20	32	2.70	5.70	2.00	22.00	47.00	6.00
6.002	GT106.3257.020.32.60.R	6.00	0.20	32	2.70	5.70	2.00	32.00	57.00	6.00
6.003	GT106.3257.020.42.60.R	6.00	0.20	32	2.70	5.70	2.00	42.00	67.00	6.00
6.004	GT106.3257.020.52.60.R	6.00	0.20	32	2.70	5.70	2.00	52.00	77.00	6.00

Series no.	25733	25735	25739
Cutting direction	(L)	(L)	(L)

Code no.	Description	D min	R	W1	f	a	t max	La	Lg	D h6
		mm	mm	°	mm	mm	mm	mm	mm	mm
6.013	GT106.3257.020.12.60.L	6.00	0.20	32	2.70	5.70	2.00	12.00	37.00	6.00
6.014	GT106.3257.020.17.60.L	6.00	0.20	32	2.70	5.70	2.00	17.00	42.00	6.00
6.001	GT106.3257.020.22.60.L	6.00	0.20	32	2.70	5.70	2.00	22.00	47.00	6.00
6.002	GT106.3257.020.32.60.L	6.00	0.20	32	2.70	5.70	2.00	32.00	57.00	6.00
6.003	GT106.3257.020.42.60.L	6.00	0.20	32	2.70	5.70	2.00	42.00	67.00	6.00
6.004	GT106.3257.020.52.60.L	6.00	0.20	32	2.70	5.70	2.00	52.00	77.00	6.00



Cutting insert for boring out and chamfering

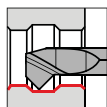

• 45° both sides

for tool holders type GB106 see from page 62

Tool material	Solid carbide		
Type	GT 106	GT 106	GT 106
Surface			
	TiN	nano-A	bright

Cutting data page 148

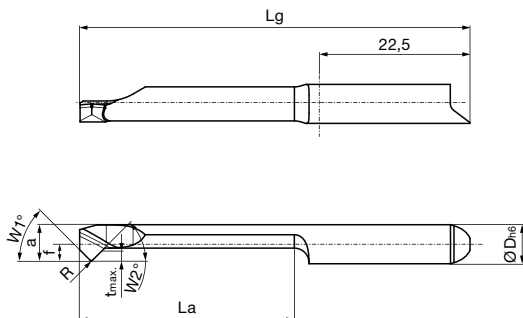



Right hand version shown
Left hand version mirror image



Series no.	25740	25742	25746
Cutting direction			

Code no.	Description	D min	R	W1	W2	f	a	t max	La	Lg	D h6
		mm	mm	°	°	mm	mm	mm	mm	mm	mm
6.019	GT106.4557.010.12.60.R	6.00	0.10	45	45	2.70	5.70	1.00	12.00	37.00	6.00
6.020	GT106.4557.010.17.60.R	6.00	0.10	45	45	2.70	5.70	1.00	17.00	42.00	6.00
6.021	GT106.4557.010.22.60.R	6.00	0.10	45	45	2.70	5.70	1.00	22.00	47.00	6.00
6.022	GT106.4557.010.27.60.R	6.00	0.10	45	45	2.70	5.70	1.00	27.00	52.00	6.00
6.023	GT106.4557.010.32.60.R	6.00	0.10	45	45	2.70	5.70	1.00	32.00	57.00	6.00
6.024	GT106.4557.010.37.60.R	6.00	0.10	45	45	2.70	5.70	1.00	37.00	62.00	6.00
6.025	GT106.4557.010.42.60.R	6.00	0.10	45	45	2.70	5.70	1.00	42.00	67.00	6.00
6.026	GT106.4557.010.47.60.R	6.00	0.10	45	45	2.70	5.70	1.00	47.00	72.00	6.00
6.027	GT106.4557.010.52.60.R	6.00	0.10	45	45	2.70	5.70	1.00	52.00	77.00	6.00
6.013	GT106.4557.015.12.60.R	6.00	0.15	45	45	2.70	5.70	1.00	12.00	37.00	6.00
6.014	GT106.4557.015.17.60.R	6.00	0.15	45	45	2.70	5.70	1.00	17.00	42.00	6.00
6.015	GT106.4557.015.22.60.R	6.00	0.15	45	45	2.70	5.70	1.00	22.00	47.00	6.00
6.001	GT106.4557.015.27.60.R	6.00	0.15	45	45	2.70	5.70	1.00	27.00	52.00	6.00
6.002	GT106.4557.015.32.60.R	6.00	0.15	45	45	2.70	5.70	1.00	32.00	57.00	6.00
6.003	GT106.4557.015.37.60.R	6.00	0.15	45	45	2.70	5.70	1.00	37.00	62.00	6.00
6.004	GT106.4557.015.42.60.R	6.00	0.15	45	45	2.70	5.70	1.00	42.00	67.00	6.00
6.005	GT106.4557.015.47.60.R	6.00	0.15	45	45	2.70	5.70	1.00	47.00	72.00	6.00
6.006	GT106.4557.015.52.60.R	6.00	0.15	45	45	2.70	5.70	1.00	52.00	77.00	6.00
6.028	GT106.4557.020.12.60.R	6.00	0.20	45	45	2.70	5.70	1.00	12.00	37.00	6.00
6.029	GT106.4557.020.17.60.R	6.00	0.20	45	45	2.70	5.70	1.00	17.00	42.00	6.00
6.030	GT106.4557.020.22.60.R	6.00	0.20	45	45	2.70	5.70	1.00	22.00	47.00	6.00
6.031	GT106.4557.020.27.60.R	6.00	0.20	45	45	2.70	5.70	1.00	27.00	52.00	6.00
6.032	GT106.4557.020.32.60.R	6.00	0.20	45	45	2.70	5.70	1.00	32.00	57.00	6.00
6.033	GT106.4557.020.37.60.R	6.00	0.20	45	45	2.70	5.70	1.00	37.00	62.00	6.00
6.034	GT106.4557.020.42.60.R	6.00	0.20	45	45	2.70	5.70	1.00	42.00	67.00	6.00
6.035	GT106.4557.020.47.60.R	6.00	0.20	45	45	2.70	5.70	1.00	47.00	72.00	6.00
6.036	GT106.4557.020.52.60.R	6.00	0.20	45	45	2.70	5.70	1.00	52.00	77.00	6.00
6.016	GT106.4557.030.12.60.R	6.00	0.30	45	45	2.70	5.70	1.00	12.00	37.00	6.00
6.017	GT106.4557.030.17.60.R	6.00	0.30	45	45	2.70	5.70	1.00	17.00	42.00	6.00
6.018	GT106.4557.030.22.60.R	6.00	0.30	45	45	2.70	5.70	1.00	22.00	47.00	6.00
6.007	GT106.4557.030.27.60.R	6.00	0.30	45	45	2.70	5.70	1.00	27.00	52.00	6.00
6.008	GT106.4557.030.32.60.R	6.00	0.30	45	45	2.70	5.70	1.00	32.00	57.00	6.00
6.009	GT106.4557.030.37.60.R	6.00	0.30	45	45	2.70	5.70	1.00	37.00	62.00	6.00
6.010	GT106.4557.030.42.60.R	6.00	0.30	45	45	2.70	5.70	1.00	42.00	67.00	6.00
6.011	GT106.4557.030.47.60.R	6.00	0.30	45	45	2.70	5.70	1.00	47.00	72.00	6.00
6.012	GT106.4557.030.52.60.R	6.00	0.30	45	45	2.70	5.70	1.00	52.00	77.00	6.00

Series no. **25741** **25743** **25747**Cutting direction   

Code no.	Description	D min	R	W1	W2	f	a	t max	La	Lg	D h6
		mm	mm	°	°	mm	mm	mm	mm	mm	mm
6.019	GT106.4557.010.12.60.L	6.00	0.10	45	45	2.70	5.70	1.00	12.00	37.00	6.00
6.020	GT106.4557.010.17.60.L	6.00	0.10	45	45	2.70	5.70	1.00	17.00	42.00	6.00
6.021	GT106.4557.010.22.60.L	6.00	0.10	45	45	2.70	5.70	1.00	22.00	47.00	6.00
6.022	GT106.4557.010.27.60.L	6.00	0.10	45	45	2.70	5.70	1.00	27.00	52.00	6.00
6.023	GT106.4557.010.32.60.L	6.00	0.10	45	45	2.70	5.70	1.00	32.00	57.00	6.00
6.024	GT106.4557.010.37.60.L	6.00	0.10	45	45	2.70	5.70	1.00	37.00	62.00	6.00
6.025	GT106.4557.010.42.60.L	6.00	0.10	45	45	2.70	5.70	1.00	42.00	67.00	6.00
6.026	GT106.4557.010.47.60.L	6.00	0.10	45	45	2.70	5.70	1.00	47.00	72.00	6.00
6.027	GT106.4557.010.52.60.L	6.00	0.10	45	45	2.70	5.70	1.00	52.00	77.00	6.00
6.013	GT106.4557.015.12.60.L	6.00	0.15	45	45	2.70	5.70	1.00	12.00	37.00	6.00
6.014	GT106.4557.015.17.60.L	6.00	0.15	45	45	2.70	5.70	1.00	17.00	42.00	6.00
6.015	GT106.4557.015.22.60.L	6.00	0.15	45	45	2.70	5.70	1.00	22.00	47.00	6.00
6.001	GT106.4557.015.27.60.L	6.00	0.15	45	45	2.70	5.70	1.00	27.00	52.00	6.00
6.002	GT106.4557.015.32.60.L	6.00	0.15	45	45	2.70	5.70	1.00	32.00	57.00	6.00
6.003	GT106.4557.015.37.60.L	6.00	0.15	45	45	2.70	5.70	1.00	37.00	62.00	6.00
6.004	GT106.4557.015.42.60.L	6.00	0.15	45	45	2.70	5.70	1.00	42.00	67.00	6.00
6.005	GT106.4557.015.47.60.L	6.00	0.15	45	45	2.70	5.70	1.00	47.00	72.00	6.00
6.006	GT106.4557.015.52.60.L	6.00	0.15	45	45	2.70	5.70	1.00	52.00	77.00	6.00
6.028	GT106.4557.020.12.60.L	6.00	0.20	45	45	2.70	5.70	1.00	12.00	37.00	6.00
6.029	GT106.4557.020.17.60.L	6.00	0.20	45	45	2.70	5.70	1.00	17.00	42.00	6.00
6.030	GT106.4557.020.22.60.L	6.00	0.20	45	45	2.70	5.70	1.00	22.00	47.00	6.00
6.031	GT106.4557.020.27.60.L	6.00	0.20	45	45	2.70	5.70	1.00	27.00	52.00	6.00
6.032	GT106.4557.020.32.60.L	6.00	0.20	45	45	2.70	5.70	1.00	32.00	57.00	6.00
6.033	GT106.4557.020.37.60.L	6.00	0.20	45	45	2.70	5.70	1.00	37.00	62.00	6.00
6.034	GT106.4557.020.42.60.L	6.00	0.20	45	45	2.70	5.70	1.00	42.00	67.00	6.00
6.035	GT106.4557.020.47.60.L	6.00	0.20	45	45	2.70	5.70	1.00	47.00	72.00	6.00
6.036	GT106.4557.020.52.60.L	6.00	0.20	45	45	2.70	5.70	1.00	52.00	77.00	6.00
6.016	GT106.4557.030.12.60.L	6.00	0.30	45	45	2.70	5.70	1.00	12.00	37.00	6.00
6.017	GT106.4557.030.17.60.L	6.00	0.30	45	45	2.70	5.70	1.00	17.00	42.00	6.00
6.018	GT106.4557.030.22.60.L	6.00	0.30	45	45	2.70	5.70	1.00	22.00	47.00	6.00
6.007	GT106.4557.030.27.60.L	6.00	0.30	45	45	2.70	5.70	1.00	27.00	52.00	6.00
6.008	GT106.4557.030.32.60.L	6.00	0.30	45	45	2.70	5.70	1.00	32.00	57.00	6.00
6.009	GT106.4557.030.37.60.L	6.00	0.30	45	45	2.70	5.70	1.00	37.00	62.00	6.00
6.010	GT106.4557.030.42.60.L	6.00	0.30	45	45	2.70	5.70	1.00	42.00	67.00	6.00
6.011	GT106.4557.030.47.60.L	6.00	0.30	45	45	2.70	5.70	1.00	47.00	72.00	6.00
6.012	GT106.4557.030.52.60.L	6.00	0.30	45	45	2.70	5.70	1.00	52.00	77.00	6.00



Cutting insert for internal grooving, straight slots

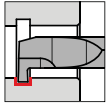

• grooving depth up to 2 mm

for tool holders type GB106 see from page 62

Cutting data page 148

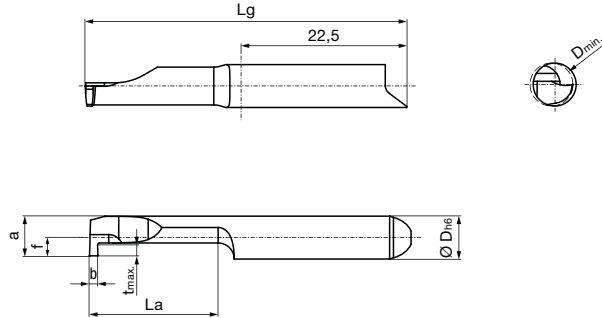

Right hand version shown
Left hand version mirror image

Tool material	Solid carbide		
	GE 106	GE 106	GE 106
Type			
Surface	S	a	○
	TiN	nano-A	bright



Series no.	25748	25750	25754
Cutting direction	R	R	R

Code no.	Description	D min	b	f	a	t max	La	Lg	D h6
		mm	mm	mm	mm	mm	mm	mm	mm
6.001	GE106.0100.000.12.60.R	6.00	1.00	2.70	5.70	2.00	12.00	37.00	6.00
6.002	GE106.0100.000.17.60.R	6.00	1.00	2.70	5.70	2.00	17.00	42.00	6.00
6.003	GE106.0100.000.22.60.R	6.00	1.00	2.70	5.70	2.00	22.00	47.00	6.00
6.004	GE106.0100.000.27.60.R	6.00	1.00	2.70	5.70	2.00	27.00	52.00	6.00
6.005	GE106.0100.000.32.60.R	6.00	1.00	2.70	5.70	2.00	32.00	57.00	6.00
6.006	GE106.0100.000.37.60.R	6.00	1.00	2.70	5.70	2.00	37.00	62.00	6.00
6.007	GE106.0100.000.42.60.R	6.00	1.00	2.70	5.70	2.00	42.00	67.00	6.00
6.008	GE106.0150.000.12.60.R	6.00	1.50	2.70	5.70	2.00	12.00	37.00	6.00
6.009	GE106.0150.000.17.60.R	6.00	1.50	2.70	5.70	2.00	17.00	42.00	6.00
6.010	GE106.0150.000.22.60.R	6.00	1.50	2.70	5.70	2.00	22.00	47.00	6.00
6.011	GE106.0150.000.27.60.R	6.00	1.50	2.70	5.70	2.00	27.00	52.00	6.00
6.012	GE106.0150.000.32.60.R	6.00	1.50	2.70	5.70	2.00	32.00	57.00	6.00
6.013	GE106.0150.000.37.60.R	6.00	1.50	2.70	5.70	2.00	37.00	62.00	6.00
6.014	GE106.0150.000.42.60.R	6.00	1.50	2.70	5.70	2.00	42.00	67.00	6.00
6.015	GE106.0200.000.12.60.R	6.00	2.00	2.70	5.70	2.00	12.00	37.00	6.00
6.016	GE106.0200.000.17.60.R	6.00	2.00	2.70	5.70	2.00	17.00	42.00	6.00
6.017	GE106.0200.000.22.60.R	6.00	2.00	2.70	5.70	2.00	22.00	47.00	6.00
6.018	GE106.0200.000.27.60.R	6.00	2.00	2.70	5.70	2.00	27.00	52.00	6.00
6.019	GE106.0200.000.32.60.R	6.00	2.00	2.70	5.70	2.00	32.00	57.00	6.00
6.020	GE106.0200.000.37.60.R	6.00	2.00	2.70	5.70	2.00	37.00	62.00	6.00
6.021	GE106.0200.000.42.60.R	6.00	2.00	2.70	5.70	2.00	42.00	67.00	6.00

Series no.	25749	25751	25755
Cutting direction	L	L	L

Code no.	Description	D min	b	f	a	t max	La	Lg	D h6
		mm	mm	mm	mm	mm	mm	mm	mm
6.001	GE106.0100.000.12.60.L	6.00	1.00	2.70	5.70	2.00	12.00	37.00	6.00
6.002	GE106.0100.000.17.60.L	6.00	1.00	2.70	5.70	2.00	17.00	42.00	6.00
6.003	GE106.0100.000.22.60.L	6.00	1.00	2.70	5.70	2.00	22.00	47.00	6.00
6.004	GE106.0100.000.27.60.L	6.00	1.00	2.70	5.70	2.00	27.00	52.00	6.00
6.005	GE106.0100.000.32.60.L	6.00	1.00	2.70	5.70	2.00	32.00	57.00	6.00
6.006	GE106.0100.000.37.60.L	6.00	1.00	2.70	5.70	2.00	37.00	62.00	6.00

System 106



Series no. **25749** **25751** **25755**

Cutting direction

Code no.	Description	D min	b	f	a	t max	La	Lg	D h6
		mm	mm	mm	mm	mm	mm	mm	mm
6.007	GE106.0100.000.42.60.L	6.00	1.00	2.70	5.70	2.00	42.00	67.00	6.00
6.008	GE106.0150.000.12.60.L	6.00	1.50	2.70	5.70	2.00	12.00	37.00	6.00
6.009	GE106.0150.000.17.60.L	6.00	1.50	2.70	5.70	2.00	17.00	42.00	6.00
6.010	GE106.0150.000.22.60.L	6.00	1.50	2.70	5.70	2.00	22.00	47.00	6.00
6.011	GE106.0150.000.27.60.L	6.00	1.50	2.70	5.70	2.00	27.00	52.00	6.00
6.012	GE106.0150.000.32.60.L	6.00	1.50	2.70	5.70	2.00	32.00	57.00	6.00
6.013	GE106.0150.000.37.60.L	6.00	1.50	2.70	5.70	2.00	37.00	62.00	6.00
6.014	GE106.0150.000.42.60.L	6.00	1.50	2.70	5.70	2.00	42.00	67.00	6.00
6.015	GE106.0200.000.12.60.L	6.00	2.00	2.70	5.70	2.00	12.00	37.00	6.00
6.016	GE106.0200.000.17.60.L	6.00	2.00	2.70	5.70	2.00	17.00	42.00	6.00
6.017	GE106.0200.000.22.60.L	6.00	2.00	2.70	5.70	2.00	22.00	47.00	6.00
6.018	GE106.0200.000.27.60.L	6.00	2.00	2.70	5.70	2.00	27.00	52.00	6.00
6.019	GE106.0200.000.32.60.L	6.00	2.00	2.70	5.70	2.00	32.00	57.00	6.00
6.020	GE106.0200.000.37.60.L	6.00	2.00	2.70	5.70	2.00	37.00	62.00	6.00
6.021	GE106.0200.000.42.60.L	6.00	2.00	2.70	5.70	2.00	42.00	67.00	6.00

System 106



Cutting insert for internal grooving, full radius slots

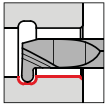

• full radius R0.5-R1.0

for tool holders type GB106 see from page 62

Cutting data page 148

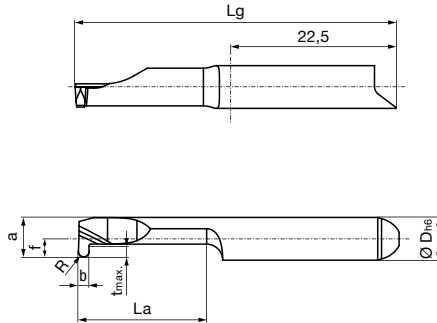

Right hand version shown
Left hand version mirror image

Tool material	Solid carbide		
Type	GE 106	GE 106	GE 106
Surface			
	TiN	nano-A	bright



Series no. **25756** **25758** **25762**

Cutting direction

Code no.	Description	D min	b	R	f	a	t max	La	Lg	D h6
		mm	mm	mm	mm	mm	mm	mm	mm	mm
6.001	GE106.0100.050.12.60.R	6.00	1.00	0.50	2.70	5.70	2.00	12.00	37.00	6.00
6.002	GE106.0100.050.17.60.R	6.00	1.00	0.50	2.70	5.70	2.00	17.00	42.00	6.00
6.003	GE106.0100.050.22.60.R	6.00	1.00	0.50	2.70	5.70	2.00	22.00	47.00	6.00
6.004	GE106.0100.050.27.60.R	6.00	1.00	0.50	2.70	5.70	2.00	27.00	52.00	6.00
6.005	GE106.0100.050.32.60.R	6.00	1.00	0.50	2.70	5.70	2.00	32.00	57.00	6.00
6.006	GE106.0100.050.37.60.R	6.00	1.00	0.50	2.70	5.70	2.00	37.00	62.00	6.00
6.007	GE106.0100.050.42.60.R	6.00	1.00	0.50	2.70	5.70	2.00	42.00	67.00	6.00
6.008	GE106.0150.075.12.60.R	6.00	1.50	0.75	2.70	5.70	2.00	12.00	37.00	6.00
6.009	GE106.0150.075.17.60.R	6.00	1.50	0.75	2.70	5.70	2.00	17.00	42.00	6.00
6.010	GE106.0150.075.22.60.R	6.00	1.50	0.75	2.70	5.70	2.00	22.00	47.00	6.00
6.011	GE106.0150.075.27.60.R	6.00	1.50	0.75	2.70	5.70	2.00	27.00	52.00	6.00
6.012	GE106.0150.075.32.60.R	6.00	1.50	0.75	2.70	5.70	2.00	32.00	57.00	6.00
6.013	GE106.0150.075.37.60.R	6.00	1.50	0.75	2.70	5.70	2.00	37.00	62.00	6.00
6.014	GE106.0150.075.42.60.R	6.00	1.50	0.75	2.70	5.70	2.00	42.00	67.00	6.00
6.015	GE106.0200.100.12.60.R	6.00	2.00	1.00	2.70	5.70	2.00	12.00	37.00	6.00
6.016	GE106.0200.100.17.60.R	6.00	2.00	1.00	2.70	5.70	2.00	17.00	42.00	6.00
6.017	GE106.0200.100.22.60.R	6.00	2.00	1.00	2.70	5.70	2.00	22.00	47.00	6.00
6.018	GE106.0200.100.27.60.R	6.00	2.00	1.00	2.70	5.70	2.00	27.00	52.00	6.00
6.019	GE106.0200.100.32.60.R	6.00	2.00	1.00	2.70	5.70	2.00	32.00	57.00	6.00
6.020	GE106.0200.100.37.60.R	6.00	2.00	1.00	2.70	5.70	2.00	37.00	62.00	6.00
6.021	GE106.0200.100.42.60.R	6.00	2.00	1.00	2.70	5.70	2.00	42.00	67.00	6.00

Series no. **25757** **25759** **25763**

Cutting direction

Code no.	Description	D min	b	R	f	a	t max	La	Lg	D h6
		mm	mm	mm	mm	mm	mm	mm	mm	mm
6.001	GE106.0100.050.12.60.L	6.00	1.00	0.50	2.70	5.70	2.00	12.00	37.00	6.00
6.002	GE106.0100.050.17.60.L	6.00	1.00	0.50	2.70	5.70	2.00	17.00	42.00	6.00
6.003	GE106.0100.050.22.60.L	6.00	1.00	0.50	2.70	5.70	2.00	22.00	47.00	6.00
6.004	GE106.0100.050.27.60.L	6.00	1.00	0.50	2.70	5.70	2.00	27.00	52.00	6.00
6.005	GE106.0100.050.32.60.L	6.00	1.00	0.50	2.70	5.70	2.00	32.00	57.00	6.00
6.006	GE106.0100.050.37.60.L	6.00	1.00	0.50	2.70	5.70	2.00	37.00	62.00	6.00



Series no. **25757** **25759** **25763**

Cutting direction   

System 106

Code no.	Description	D min	b	R	f	a	t max	La	Lg	D h6
		mm	mm	mm	mm	mm	mm	mm	mm	mm
6.007	GE106.0100.050.42.60.L	6.00	1.00	0.50	2.70	5.70	2.00	42.00	67.00	6.00
6.008	GE106.0150.075.12.60.L	6.00	1.50	0.75	2.70	5.70	2.00	12.00	37.00	6.00
6.009	GE106.0150.075.17.60.L	6.00	1.50	0.75	2.70	5.70	2.00	17.00	42.00	6.00
6.010	GE106.0150.075.22.60.L	6.00	1.50	0.75	2.70	5.70	2.00	22.00	47.00	6.00
6.011	GE106.0150.075.27.60.L	6.00	1.50	0.75	2.70	5.70	2.00	27.00	52.00	6.00
6.012	GE106.0150.075.32.60.L	6.00	1.50	0.75	2.70	5.70	2.00	32.00	57.00	6.00
6.013	GE106.0150.075.37.60.L	6.00	1.50	0.75	2.70	5.70	2.00	37.00	62.00	6.00
6.014	GE106.0150.075.42.60.L	6.00	1.50	0.75	2.70	5.70	2.00	42.00	67.00	6.00
6.015	GE106.0200.100.12.60.L	6.00	2.00	1.00	2.70	5.70	2.00	12.00	37.00	6.00
6.016	GE106.0200.100.17.60.L	6.00	2.00	1.00	2.70	5.70	2.00	17.00	42.00	6.00
6.017	GE106.0200.100.22.60.L	6.00	2.00	1.00	2.70	5.70	2.00	22.00	47.00	6.00
6.018	GE106.0200.100.27.60.L	6.00	2.00	1.00	2.70	5.70	2.00	27.00	52.00	6.00
6.019	GE106.0200.100.32.60.L	6.00	2.00	1.00	2.70	5.70	2.00	32.00	57.00	6.00
6.020	GE106.0200.100.37.60.L	6.00	2.00	1.00	2.70	5.70	2.00	37.00	62.00	6.00
6.021	GE106.0200.100.42.60.L	6.00	2.00	1.00	2.70	5.70	2.00	42.00	67.00	6.00



Cutting insert for axial grooving bores, straight slots

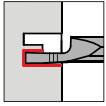

- grooving depth up to 8 mm

for tool holders type GB106 see from page 62

Tool material	Solid carbide		
Type	GA 106	GA 106	GA 106
Surface	S	a	○
	TiN	nano-A	bright

Cutting data page 148

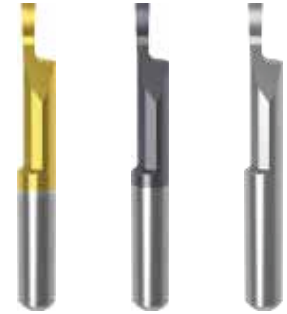
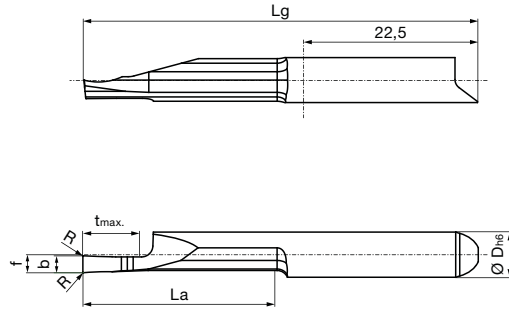

Right hand version shown
Left hand version mirror image

Series no.	25780	25782	25786
Cutting direction	R	R	R

Code no.	Description	D min	b	R	f	t max	La	Lg	D h6
		mm	mm	mm	mm	mm	mm	mm	mm
6.001	GA106.0150.010.17.60.R	6.00	1.50	0.10	2.60	5.00	17.00	42.00	6.00
6.002	GA106.0150.010.22.60.R	6.00	1.50	0.10	2.60	5.00	22.00	47.00	6.00
6.003	GA106.0200.015.17.60.R	6.00	2.00	0.15	2.60	8.00	17.00	42.00	6.00
6.004	GA106.0200.015.22.60.R	6.00	2.00	0.15	2.60	8.00	22.00	47.00	6.00

Series no.	25781	25783	25787
Cutting direction	L	L	L

Code no.	Description	D min	b	R	f	t max	La	Lg	D h6
		mm	mm	mm	mm	mm	mm	mm	mm
6.001	GA106.0150.010.17.60.L	6.00	1.50	0.10	2.60	5.00	17.00	42.00	6.00
6.002	GA106.0150.010.22.60.L	6.00	1.50	0.10	2.60	5.00	22.00	47.00	6.00
6.003	GA106.0200.015.17.60.L	6.00	2.00	0.15	2.60	8.00	17.00	42.00	6.00
6.004	GA106.0200.015.22.60.L	6.00	2.00	0.15	2.60	8.00	22.00	47.00	6.00



Cutting insert for axial grooving bores, full radius slots

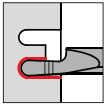

- grooving depth up to 8 mm

for tool holders type GB106 see from page 62

Tool material	Solid carbide		
Type	GA 106	GA 106	GA 106
Surface			
	TiN	nano-A	bright

Cutting data page 148

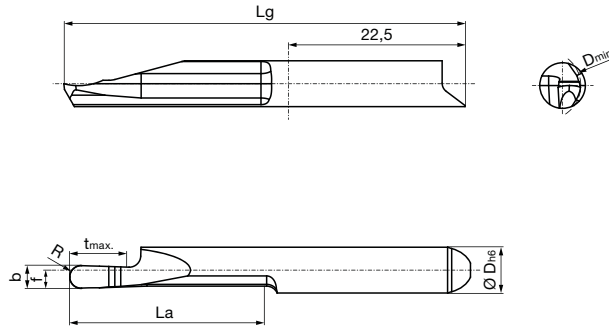

Right hand version shown
Left hand version mirror image



Series no.	25788	25790	25794
Cutting direction			

Code no.	Description	D min	b	R	f	t max	La	Lg	D h6
		mm	mm	mm	mm	mm	mm	mm	mm
6.001	GA106.0150.075.17.60.R	6.00	1.50	0.75	2.60	5.00	17.00	42.00	6.00
6.002	GA106.0150.075.22.60.R	6.00	1.50	0.75	2.60	5.00	22.00	47.00	6.00
6.003	GA106.0200.100.17.60.R	6.00	2.00	1.00	2.60	8.00	17.00	42.00	6.00
6.004	GA106.0200.100.22.60.R	6.00	2.00	1.00	2.60	8.00	22.00	47.00	6.00

Series no.	25789	25791	25795
Cutting direction			

Code no.	Description	D min	b	R	f	t max	La	Lg	D h6
		mm	mm	mm	mm	mm	mm	mm	mm
6.001	GA106.0150.075.17.60.L	6.00	1.50	0.75	2.60	5.00	17.00	42.00	6.00
6.002	GA106.0150.075.22.60.L	6.00	1.50	0.75	2.60	5.00	22.00	47.00	6.00
6.003	GA106.0200.100.17.60.L	6.00	2.00	1.00	2.60	8.00	17.00	42.00	6.00
6.004	GA106.0200.100.22.60.L	6.00	2.00	1.00	2.60	8.00	22.00	47.00	6.00



Cutting insert for axial grooving studs, straight slots

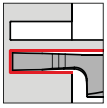

- grooving depth up to 8 mm

for tool holders type GB106 see from page 62

Cutting data page 148

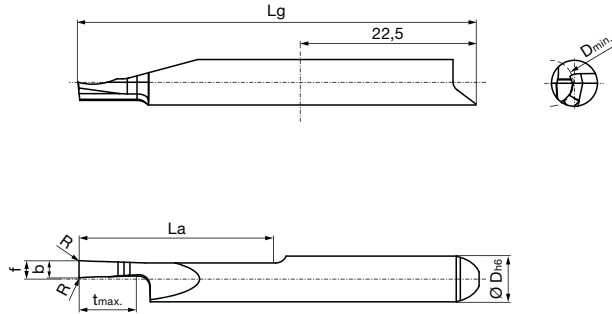

Right hand version shown
Left hand version mirror image

Tool material	Solid carbide		
Type	GA 106	GA 106	GA 106
Surface			
	TiN	nano-A	bright



Series no. **25796** **25798** **25802**

Cutting direction

Code no.	Description	D min	b	R	f	t max	La	Lg	D h6
		mm	mm	mm	mm	mm	mm	mm	mm
6.001	GA106.Z150.010.17.60.R	6.00	1.50	0.10	2.60	5.00	17.00	42.00	6.00
6.002	GA106.Z150.010.22.60.R	6.00	1.50	0.10	2.60	5.00	22.00	47.00	6.00
6.003	GA106.Z200.015.17.60.R	6.00	2.00	0.15	2.60	8.00	17.00	42.00	6.00
6.004	GA106.Z200.015.22.60.R	6.00	2.00	0.15	2.60	8.00	22.00	47.00	6.00

Series no. **25797** **25799** **25803**

Cutting direction

Code no.	Description	D min	b	R	f	t max	La	Lg	D h6
		mm	mm	mm	mm	mm	mm	mm	mm
6.001	GA106.Z150.010.17.60.L	6.00	1.50	0.10	2.60	5.00	17.00	42.00	6.00
6.002	GA106.Z150.010.22.60.L	6.00	1.50	0.10	2.60	5.00	22.00	47.00	6.00
6.003	GA106.Z200.015.17.60.L	6.00	2.00	0.15	2.60	8.00	17.00	42.00	6.00
6.004	GA106.Z200.015.22.60.L	6.00	2.00	0.15	2.60	8.00	22.00	47.00	6.00

System 106



Cutting insert for axial grooving studs, full radius slots

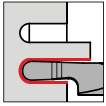

• grooving depth up to 8 mm

for tool holders type GB106 see from page 62

Cutting data page 148

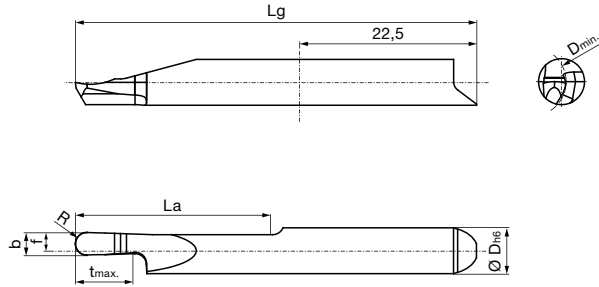

Right hand version shown
Left hand version mirror image

Tool material	Solid carbide		
Type	GA 106	GA 106	GA 106
Surface			
	TiN	nano-A	bright



Series no. **25804** **25806** **25810**

Cutting direction

Code no.	Description	D min	b	R	f	t max	La	Lg	D h6
		mm	mm	mm	mm	mm	mm	mm	mm
6.001	GA106.Z150.075.17.60.R	6.00	1.50	0.75	2.60	5.00	17.00	42.00	6.00
6.002	GA106.Z150.075.22.60.R	6.00	1.50	0.75	2.60	5.00	22.00	47.00	6.00
6.003	GA106.Z200.100.17.60.R	6.00	2.00	1.00	2.60	8.00	17.00	42.00	6.00
6.004	GA106.Z200.100.22.60.R	6.00	2.00	1.00	2.60	8.00	22.00	47.00	6.00

Series no. **25805** **25807** **25811**

Cutting direction

Code no.	Description	D min	b	R	f	t max	La	Lg	D h6
		mm	mm	mm	mm	mm	mm	mm	mm
6.001	GA106.Z150.075.17.60.L	6.00	1.50	0.75	2.60	5.00	17.00	42.00	6.00
6.002	GA106.Z150.075.22.60.L	6.00	1.50	0.75	2.60	5.00	22.00	47.00	6.00
6.003	GA106.Z200.100.17.60.L	6.00	2.00	1.00	2.60	8.00	17.00	42.00	6.00
6.004	GA106.Z200.100.22.60.L	6.00	2.00	1.00	2.60	8.00	22.00	47.00	6.00



Cutting insert for internal threading, partial profile - metric standard threads

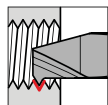

• pitch P = 1.25-1.75

for tool holders type GB106 see from page 62

Cutting data page 148

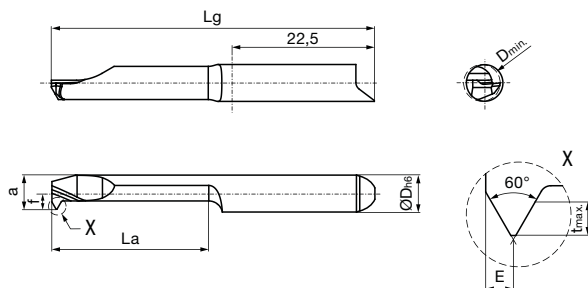

Right hand version shown
Left hand version mirror image



Tool material	Solid carbide		
Type	GG 106	GG 106	GG 106
Surface	S	a	○
	TiN	nano-A	bright

Series no.	25764	25766	25770
Cutting direction	R	R	R

Code no.	Description	G	P	D min	f	E	a	t max	La	Lg	D h6
			mm	mm	mm	mm	mm	mm	mm	mm	mm
6.010	GG106.TM08.125.12.68.R	M8	1.25	6.80	2.95	0.70	5.95	0.70	12.00	37.00	6.00
6.001	GG106.TM08.125.17.68.R	M8	1.25	6.80	2.95	0.70	5.95	0.70	17.00	42.00	6.00
6.002	GG106.TM08.125.22.68.R	M8	1.25	6.80	2.95	0.70	5.95	0.70	22.00	47.00	6.00
6.003	GG106.TM08.125.27.68.R	M8	1.25	6.80	2.95	0.70	5.95	0.70	27.00	52.00	6.00
6.011	GG106.TM08.125.32.68.R	M8	1.25	6.80	2.95	0.70	5.95	0.70	32.00	57.00	6.00
6.012	GG106.TM08.125.37.68.R	M8	1.25	6.80	2.95	0.70	5.95	0.70	37.00	62.00	6.00
6.013	GG106.TM08.125.42.68.R	M8	1.25	6.80	2.95	0.70	5.95	0.70	42.00	67.00	6.00
6.014	GG106.TM10.150.12.85.R	M10	1.50	8.50	2.95	0.85	5.95	0.85	12.00	37.00	6.00
6.004	GG106.TM10.150.17.85.R	M10	1.50	8.50	2.95	0.85	5.95	0.85	17.00	42.00	6.00
6.005	GG106.TM10.150.22.85.R	M10	1.50	8.50	2.95	0.85	5.95	0.85	22.00	47.00	6.00
6.006	GG106.TM10.150.27.85.R	M10	1.50	8.50	2.95	0.85	5.95	0.85	27.00	52.00	6.00
6.015	GG106.TM10.150.32.85.R	M10	1.50	8.50	2.95	0.85	5.95	0.85	32.00	57.00	6.00
6.016	GG106.TM10.150.37.85.R	M10	1.50	8.50	2.95	0.85	5.95	0.85	37.00	62.00	6.00
6.017	GG106.TM10.150.42.85.R	M10	1.50	8.50	2.95	0.85	5.95	0.85	42.00	67.00	6.00
6.018	GG106.TM12.175.12.99.R	M12	1.75	10.20	2.95	1.00	5.95	1.00	12.00	37.00	6.00
6.007	GG106.TM12.175.17.99.R	M12	1.75	10.20	2.95	1.00	5.95	1.00	17.00	42.00	6.00
6.008	GG106.TM12.175.22.99.R	M12	1.75	10.20	2.95	1.00	5.95	1.00	22.00	47.00	6.00
6.009	GG106.TM12.175.27.99.R	M12	1.75	10.20	2.95	1.00	5.95	1.00	27.00	52.00	6.00
6.019	GG106.TM12.175.32.99.R	M12	1.75	10.20	2.95	1.00	5.95	1.00	32.00	57.00	6.00
6.020	GG106.TM12.175.37.99.R	M12	1.75	10.20	2.95	1.00	5.95	1.00	37.00	62.00	6.00
6.021	GG106.TM12.175.42.99.R	M12	1.75	10.20	2.95	1.00	5.95	1.00	42.00	67.00	6.00

Series no.	25765	25767	25771
Cutting direction	L	L	L

Code no.	Description	G	P	D min	f	E	a	t max	La	Lg	D h6
			mm	mm	mm	mm	mm	mm	mm	mm	mm
6.010	GG106.TM08.125.12.68.L	M8	1.25	6.80	2.95	0.70	5.95	0.70	12.00	37.00	6.00
6.001	GG106.TM08.125.17.68.L	M8	1.25	6.80	2.95	0.70	5.95	0.70	17.00	42.00	6.00
6.002	GG106.TM08.125.22.68.L	M8	1.25	6.80	2.95	0.70	5.95	0.70	22.00	47.00	6.00
6.003	GG106.TM08.125.27.68.L	M8	1.25	6.80	2.95	0.70	5.95	0.70	27.00	52.00	6.00
6.011	GG106.TM08.125.32.68.L	M8	1.25	6.80	2.95	0.70	5.95	0.70	32.00	57.00	6.00
6.012	GG106.TM08.125.37.68.L	M8	1.25	6.80	2.95	0.70	5.95	0.70	37.00	62.00	6.00



Series no. **25765** **25767** **25771**

Cutting direction   

Code no.	Description	G	P	D min	f	E	a	t max	La	Lg	D h6
			mm	mm	mm	mm	mm	mm	mm	mm	mm
6.013	GG106.TM08.125.42.68.L	M8	1.25	6.80	2.95	0.70	5.95	0.70	42.00	67.00	6.00
6.014	GG106.TM10.150.12.85.L	M10	1.50	8.50	2.95	0.85	5.95	0.85	12.00	37.00	6.00
6.004	GG106.TM10.150.17.85.L	M10	1.50	8.50	2.95	0.85	5.95	0.85	17.00	42.00	6.00
6.005	GG106.TM10.150.22.85.L	M10	1.50	8.50	2.95	0.85	5.95	0.85	22.00	47.00	6.00
6.006	GG106.TM10.150.27.85.L	M10	1.50	8.50	2.95	0.85	5.95	0.85	27.00	52.00	6.00
6.015	GG106.TM10.150.32.85.L	M10	1.50	8.50	2.95	0.85	5.95	0.85	32.00	57.00	6.00
6.016	GG106.TM10.150.37.85.L	M10	1.50	8.50	2.95	0.85	5.95	0.85	37.00	62.00	6.00
6.017	GG106.TM10.150.42.85.L	M10	1.50	8.50	2.95	0.85	5.95	0.85	42.00	67.00	6.00
6.018	GG106.TM12.175.12.99.L	M12	1.75	10.20	2.95	1.00	5.95	1.00	12.00	37.00	6.00
6.007	GG106.TM12.175.17.99.L	M12	1.75	10.20	2.95	1.00	5.95	1.00	17.00	42.00	6.00
6.008	GG106.TM12.175.22.99.L	M12	1.75	10.20	2.95	1.00	5.95	1.00	22.00	47.00	6.00
6.009	GG106.TM12.175.27.99.L	M12	1.75	10.20	2.95	1.00	5.95	1.00	27.00	52.00	6.00
6.019	GG106.TM12.175.32.99.L	M12	1.75	10.20	2.95	1.00	5.95	1.00	32.00	57.00	6.00
6.020	GG106.TM12.175.37.99.L	M12	1.75	10.20	2.95	1.00	5.95	1.00	37.00	62.00	6.00
6.021	GG106.TM12.175.42.99.L	M12	1.75	10.20	2.95	1.00	5.95	1.00	42.00	67.00	6.00

System 106



Cutting insert for internal threading, full profile - metric standard threads

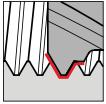

• pitch P = 1-1.75

for tool holders type GB106 see from page 62

Cutting data page 148

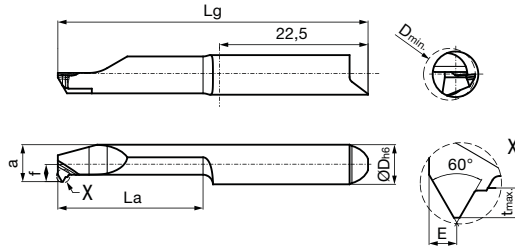

Right hand version shown
Left hand version mirror image

Tool material	Solid carbide		
Type	GG 106	GG 106	GG 106
Surface	S	a	○
	TiN	nano-A	bright

Series no. **25772** **25774** **25778**

Cutting direction **R** **R** **R**

Code no.	Description	G	P	D min	f	E	a	t max	La	Lg	D h6
			mm	mm	mm	mm	mm	mm	mm	mm	mm
6.010	GG106.VM06.100.12.50.R	M6	1.00	5.00	2.95	0.50	4.50	0.60	12.00	37.00	6.00
6.020	GG106.VM06.100.17.50.R	M6	1.00	5.00	2.95	0.50	4.50	0.60	17.00	42.00	6.00
6.030	GG106.VM06.100.22.50.R	M6	1.00	5.00	2.95	0.50	4.50	0.60	22.00	47.00	6.00
6.040	GG106.VM06.100.27.50.R	M6	1.00	5.00	2.95	0.50	4.50	0.60	27.00	52.00	6.00
6.050	GG106.VM06.100.32.50.R	M6	1.00	5.00	2.95	0.50	4.50	0.60	32.00	57.00	6.00
6.060	GG106.VM06.100.37.50.R	M6	1.00	5.00	2.95	0.50	4.50	0.60	37.00	62.00	6.00
6.070	GG106.VM06.100.42.50.R	M6	1.00	5.00	2.95	0.50	4.50	0.60	42.00	67.00	6.00
6.110	GG106.VM08.125.12.68.R	M8	1.25	6.80	2.95	0.70	5.95	0.75	12.00	37.00	6.00
6.120	GG106.VM08.125.17.68.R	M8	1.25	6.80	2.95	0.70	5.95	0.75	17.00	42.00	6.00
6.130	GG106.VM08.125.22.68.R	M8	1.25	6.80	2.95	0.70	5.95	0.75	22.00	47.00	6.00
6.140	GG106.VM08.125.27.68.R	M8	1.25	6.80	2.95	0.70	5.95	0.75	27.00	52.00	6.00
6.150	GG106.VM08.125.32.68.R	M8	1.25	6.80	2.95	0.70	5.95	0.75	32.00	57.00	6.00
6.160	GG106.VM08.125.37.68.R	M8	1.25	6.80	2.95	0.70	5.95	0.75	37.00	62.00	6.00
6.170	GG106.VM08.125.42.68.R	M8	1.25	6.80	2.95	0.70	5.95	0.75	42.00	67.00	6.00
6.210	GG106.VM10.150.12.85.R	M10	1.50	8.50	2.95	0.90	5.95	0.90	12.00	37.00	6.00
6.220	GG106.VM10.150.17.85.R	M10	1.50	8.50	2.95	0.90	5.95	0.90	17.00	42.00	6.00
6.230	GG106.VM10.150.22.85.R	M10	1.50	8.50	2.95	0.90	5.95	0.90	22.00	47.00	6.00
6.240	GG106.VM10.150.27.85.R	M10	1.50	8.50	2.95	0.90	5.95	0.90	27.00	52.00	6.00
6.250	GG106.VM10.150.32.85.R	M10	1.50	8.50	2.95	0.90	5.95	0.90	32.00	57.00	6.00
6.260	GG106.VM10.150.37.85.R	M10	1.50	8.50	2.95	0.90	5.95	0.90	37.00	62.00	6.00
6.270	GG106.VM10.150.42.85.R	M10	1.50	8.50	2.95	0.90	5.95	0.90	42.00	67.00	6.00
6.310	GG106.VM12.175.12.00.R	M12	1.75	10.20	2.95	0.90	5.95	1.05	12.00	37.00	6.00
6.320	GG106.VM12.175.17.00.R	M12	1.75	10.20	2.95	0.90	5.95	1.05	17.00	42.00	6.00
6.330	GG106.VM12.175.22.00.R	M12	1.75	10.20	2.95	0.90	5.95	1.05	22.00	47.00	6.00
6.340	GG106.VM12.175.27.00.R	M12	1.75	10.20	2.95	0.90	5.95	1.05	27.00	52.00	6.00
6.350	GG106.VM12.175.32.00.R	M12	1.75	10.20	2.95	0.90	5.95	1.05	32.00	57.00	6.00
6.360	GG106.VM12.175.37.00.R	M12	1.75	10.20	2.95	0.90	5.95	1.05	37.00	62.00	6.00
6.370	GG106.VM12.175.42.00.R	M12	1.75	10.20	2.95	0.90	5.95	1.05	42.00	67.00	6.00

System 106

Series no. **25773** **25775** **25779**Cutting direction   

Code no.	Description	G	P	D min	f	E	a	t max	La	Lg	D h6
			mm	mm	mm	mm	mm	mm	mm	mm	mm
6.010	GG106.VM06.100.12.50.L	M6	1.00	5.00	2.95	0.50	4.50	0.60	12.00	37.00	6.00
6.020	GG106.VM06.100.17.50.L	M6	1.00	5.00	2.95	0.50	4.50	0.60	17.00	42.00	6.00
6.030	GG106.VM06.100.22.50.L	M6	1.00	5.00	2.95	0.50	4.50	0.60	22.00	47.00	6.00
6.040	GG106.VM06.100.27.50.L	M6	1.00	5.00	2.95	0.50	4.50	0.60	27.00	52.00	6.00
6.050	GG106.VM06.100.32.50.L	M6	1.00	5.00	2.95	0.50	4.50	0.60	32.00	57.00	6.00
6.060	GG106.VM06.100.37.50.L	M6	1.00	5.00	2.95	0.50	4.50	0.60	37.00	62.00	6.00
6.070	GG106.VM06.100.42.50.L	M6	1.00	5.00	2.95	0.50	4.50	0.60	42.00	67.00	6.00
6.110	GG106.VM08.125.12.68.L	M8	1.25	6.80	2.95	0.70	5.95	0.75	12.00	37.00	6.00
6.120	GG106.VM08.125.17.68.L	M8	1.25	6.80	2.95	0.70	5.95	0.75	17.00	42.00	6.00
6.130	GG106.VM08.125.22.68.L	M8	1.25	6.80	2.95	0.70	5.95	0.75	22.00	47.00	6.00
6.140	GG106.VM08.125.27.68.L	M8	1.25	6.80	2.95	0.70	5.95	0.75	27.00	52.00	6.00
6.150	GG106.VM08.125.32.68.L	M8	1.25	6.80	2.95	0.70	5.95	0.75	32.00	57.00	6.00
6.160	GG106.VM08.125.37.68.L	M8	1.25	6.80	2.95	0.70	5.95	0.75	37.00	62.00	6.00
6.170	GG106.VM08.125.42.68.L	M8	1.25	6.80	2.95	0.70	5.95	0.75	42.00	67.00	6.00
6.210	GG106.VM10.150.12.85.L	M10	1.50	8.50	2.95	0.90	5.95	0.90	12.00	37.00	6.00
6.220	GG106.VM10.150.17.85.L	M10	1.50	8.50	2.95	0.90	5.95	0.90	17.00	42.00	6.00
6.230	GG106.VM10.150.22.85.L	M10	1.50	8.50	2.95	0.90	5.95	0.90	22.00	47.00	6.00
6.240	GG106.VM10.150.27.85.L	M10	1.50	8.50	2.95	0.90	5.95	0.90	27.00	52.00	6.00
6.250	GG106.VM10.150.32.85.L	M10	1.50	8.50	2.95	0.90	5.95	0.90	32.00	57.00	6.00
6.260	GG106.VM10.150.37.85.L	M10	1.50	8.50	2.95	0.90	5.95	0.90	37.00	62.00	6.00
6.270	GG106.VM10.150.42.85.L	M10	1.50	8.50	2.95	0.90	5.95	0.90	42.00	67.00	6.00
6.310	GG106.VM12.175.12.00.L	M12	1.75	10.20	2.95	0.90	5.95	1.05	12.00	37.00	6.00
6.320	GG106.VM12.175.17.00.L	M12	1.75	10.20	2.95	0.90	5.95	1.05	17.00	42.00	6.00
6.330	GG106.VM12.175.22.00.L	M12	1.75	10.20	2.95	0.90	5.95	1.05	22.00	47.00	6.00
6.340	GG106.VM12.175.27.00.L	M12	1.75	10.20	2.95	0.90	5.95	1.05	27.00	52.00	6.00
6.350	GG106.VM12.175.32.00.L	M12	1.75	10.20	2.95	0.90	5.95	1.05	32.00	57.00	6.00
6.360	GG106.VM12.175.37.00.L	M12	1.75	10.20	2.95	0.90	5.95	1.05	37.00	62.00	6.00
6.370	GG106.VM12.175.42.00.L	M12	1.75	10.20	2.95	0.90	5.95	1.05	42.00	67.00	6.00



Cutting insert for internal threading, partial profile - trapezoidal thread

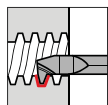

• pitch P = 1.5-3.0

for tool holders type GB106 see from page 62

Tool material	Solid carbide		
Type	GG 106	GG 106	GG 106
Surface	S	a	○
	TiN	nano-A	bright

Cutting data page 148

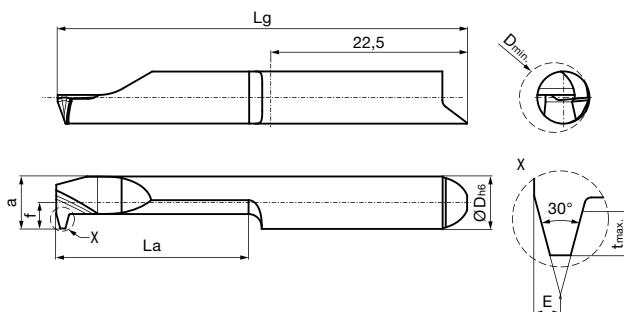

Right hand version shown
Left hand version mirror image



Series no.	25824	25826	25830
Cutting direction	R	R	R

Code no.	Description	G	P	D min	f	E	a	t max	La	Lg	D h6
			mm	mm	mm	mm	mm	mm	mm	mm	mm
6.001	GG106.TT08.150.22.65.R	Tr8	1.50	6.50	2.95	0.60	5.95	0.90	22.00	47.00	6.00
6.002	GG106.TT08.200.22.60.R	Tr8	2.00	6.00	2.70	0.75	5.70	1.25	22.00	47.00	6.00
6.003	GG106.TT10.200.22.80.R	Tr10	2.00	8.00	2.95	0.75	5.95	1.25	22.00	47.00	6.00
6.005	GG106.TT10.300.22.70.R	Tr10	3.00	7.00	2.95	1.10	5.95	1.75	22.00	47.00	6.00
6.004	GG106.TT10.200.32.80.R	Tr10	2.00	8.00	2.95	0.75	5.95	1.25	32.00	57.00	6.00
6.006	GG106.TT10.300.32.70.R	Tr10	3.00	7.00	2.95	1.10	5.95	1.75	32.00	57.00	6.00

Series no.	25825	25827	25831
Cutting direction	L	L	L

Code no.	Description	G	P	D min	f	E	a	t max	La	Lg	D h6
			mm	mm	mm	mm	mm	mm	mm	mm	mm
6.001	GG106.TT08.150.22.65.L	Tr8	1.50	6.50	2.95	0.60	5.95	0.90	22.00	47.00	6.00
6.002	GG106.TT08.200.22.60.L	Tr8	2.00	6.00	2.70	0.75	5.70	1.25	22.00	47.00	6.00
6.003	GG106.TT10.200.22.80.L	Tr10	2.00	8.00	2.95	0.75	5.95	1.25	22.00	47.00	6.00
6.005	GG106.TT10.300.22.70.L	Tr10	3.00	7.00	2.95	1.10	5.95	1.75	22.00	47.00	6.00
6.004	GG106.TT10.200.32.80.L	Tr10	2.00	8.00	2.95	0.75	5.95	1.25	32.00	57.00	6.00
6.006	GG106.TT10.300.32.70.L	Tr10	3.00	7.00	2.95	1.10	5.95	1.75	32.00	57.00	6.00

System 106

**Round shank holder, 4 clamping surfaces**

- for inserts type 106
- with internal coolant delivery

Type GB 106

System 106

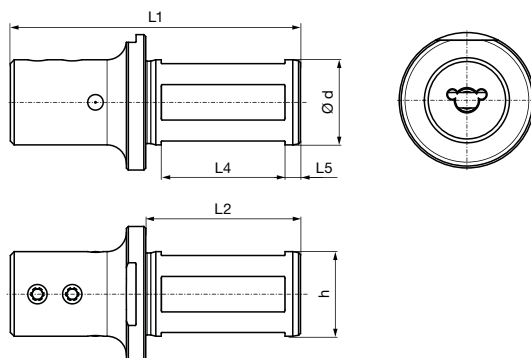
Series no. **25302**

Code no.	Description	d	d	h	L1	L2	L4	L5
		mm	inch	mm	mm	mm	mm	mm
6.010	GB106.0750.300.00.22.S.IK		3/4	17.05	76.20	40.00	32.00	4.00
6.001	GB106.0020.075.00.22.S.IK	20.00		18.00	75.00	40.00	32.00	4.00
6.002	GB106.0022.075.00.22.S.IK	22.00		20.00	75.00	40.00	32.00	4.00
6.003	GB106.0025.075.00.22.S.IK	25.00		23.00	75.00	40.00	32.00	4.00
6.011	GB106.1000.300.00.22.S.IK		1"	23.40	76.20	40.00	32.00	4.00

Spare parts

Series no.	Clamping screw	Tightening torque
25900		Nm
Code 6.000	M6x7.5x15IP	4-4.5

Series no.	Torx-Plus Wrench
25904	
Code 15.000	T15IP T-handle



Cutting insert for broaching longitudinal slots

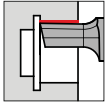

• tolerance class C11, P9, JS9

for tool holders type GB106 Series No. 25302 see page 118

Tool material	Solid carbide		
Type	GN 106	GN 106	GN 106
Surface	S	a	○
	TiN	nano-A	bright

Cutting data page 148

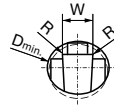
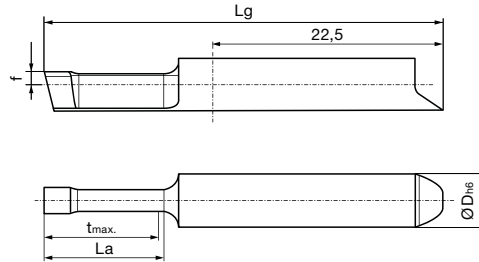

Series no. **25812** **25813** **25815**

Code no.	Description	for slot width	D min	W	R	f	t max	La	Lg	D h6
			mm	mm	mm	mm	mm	mm	mm	mm
6.001	GN106.0198.010.12.06.N	2 P9	6.00	1.98	0.10	1.50	11.50	12.00	37.00	6.00
6.002	GN106.0298.010.12.06.N	3 P9	6.00	2.98	0.10	1.50	11.50	12.00	37.00	6.00
6.003	GN106.0398.010.12.06.N	4 P9	6.00	3.98	0.10	1.50	11.50	12.00	37.00	6.00
6.004	GN106.0498.020.12.07.N	5 P9	7.00	4.98	0.20	1.50	11.50	12.00	37.00	6.00

Series no. **25816** **25817** **25819**

Code no.	Description	for slot width	D min	W	R	f	t max	La	Lg	D h6
			mm	mm	mm	mm	mm	mm	mm	mm
6.001	GN106.0200.010.12.06.N	2 JS9	6.00	2.00	0.10	1.50	11.50	12.00	37.00	6.00
6.002	GN106.0300.010.12.06.N	3 JS9	6.00	3.00	0.10	1.50	11.50	12.00	37.00	6.00
6.003	GN106.0400.010.12.06.N	4 JS9	6.00	4.00	0.10	1.50	11.50	12.00	37.00	6.00
6.004	GN106.0500.020.12.07.N	5 JS9	7.00	5.00	0.20	1.50	11.50	12.00	37.00	6.00

Series no. **25820** **25821** **25823**

Code no.	Description	for slot width	D min	W	R	f	t max	La	Lg	D h6
			mm	mm	mm	mm	mm	mm	mm	mm
6.001	GN106.0211.035.12.06.N	2 C11	6.00	2.11	0.35	1.50	11.50	12.00	37.00	6.00
6.002	GN106.0311.035.12.06.N	3 C11	6.00	3.11	0.35	1.50	11.50	12.00	37.00	6.00
6.003	GN106.0413.050.12.06.N	4 C11	6.00	4.13	0.50	1.50	11.50	12.00	37.00	6.00
6.004	GN106.0513.050.12.07.N	5 C11	7.00	5.13	0.50	1.50	11.50	12.00	37.00	6.00

System 106

305





SYSTEM 305

GROOVING AND PARTING OFF



Square shank holder straight
with and without IC
from page 122



Square shank holder, 90°
offset with and without IC
from page 127



Square shank holder, 45°
offset with and without IC
from page 131



Round shank holder
with and without IC
from page 133

Tool holder

System 305

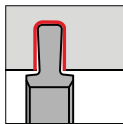

Radial grooving
straight slots, Type GE
from page 137

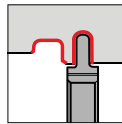

Radial grooving
full radius slots, Type GE
from page 139

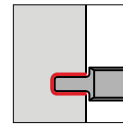

Axial grooving,
straight slots, Type GA
page 140

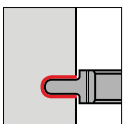

Axial grooving,
full radius slots, Type GA
page 141

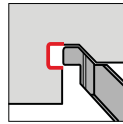

Grooving axial recesses,
Type GA
page 142

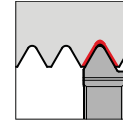

External thread turning,
Type GG
from page 143

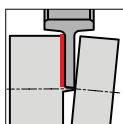

Parting off,
Type GZ
from page 145

Indexable inserts



Square shank holder straight, external machining, without IC

- grooving depth up to 5 mm
- without internal coolant delivery

Type GH 305

for indexable inserts type 305 see from page 137

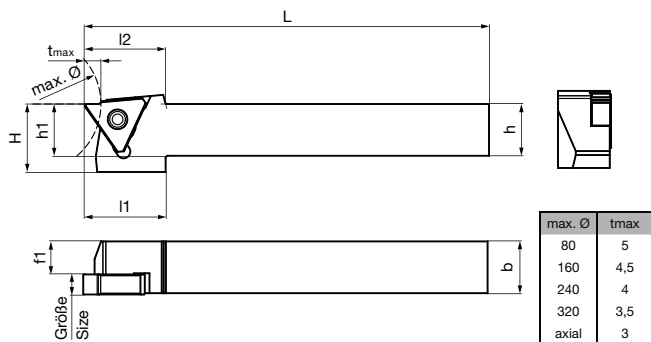

Right hand version shown
Left hand version mirror image

Series no. **25350**

version right-hand

Code no.	Description	t max	h=b	h=b	L	h1	H	l1	l2	f1	Size
		mm	mm	inch	mm	mm	mm	mm	mm	mm	
12.013	GH305.1010.125.00.04.R	5.00	10.00		125.00	10.00	20.00	24.00	25.00	8.20	04
12.014	GH305.1212.125.00.04.R	5.00	12.00		125.00	12.00	20.00	24.00	25.00	8.20	04
12.021	GH305.0625.500.00.04.R	5.00		5/8	127.00	15.87	20.87	25.40	25.40	12.07	04
12.001	GH305.1616.125.00.04.R	5.00	16.00		125.00	16.00	21.00	25.00	25.00	12.20	04
12.022	GH305.0750.500.00.04.R	5.00		3/4	127.00	19.05	24.05	25.40	25.40	15.25	04
12.002	GH305.2020.125.00.04.R	5.00	20.00		125.00	20.00	25.00	25.00	25.00	16.20	04
12.003	GH305.2525.150.00.04.R	5.00	25.00		150.00	25.00	30.00	25.00	25.00	21.20	04
12.023	GH305.1000.600.00.04.R	5.00		1"	152.40	25.40	30.40	25.40	25.40	21.60	04
12.015	GH305.1010.125.00.06.R	5.00	10.00		125.00	10.00	20.00	24.00	25.00	8.20	06
12.016	GH305.1212.125.00.06.R	5.00	12.00		125.00	12.00	20.00	24.00	25.00	8.20	06
12.024	GH305.0625.500.00.06.R	5.00		5/8	127.00	15.87	20.87	25.40	25.40	10.07	06
12.004	GH305.1616.125.00.06.R	5.00	16.00		125.00	16.00	21.00	25.00	25.00	10.20	06
12.025	GH305.0750.500.00.06.R	5.00		3/4	127.00	19.05	24.05	25.40	25.40	13.25	06
12.005	GH305.2020.125.00.06.R	5.00	20.00		125.00	20.00	25.00	25.00	25.00	14.20	06
12.006	GH305.2525.150.00.06.R	5.00	25.00		150.00	25.00	30.00	25.00	25.00	19.20	06
12.026	GH305.1000.600.00.06.R	5.00		1"	152.40	25.40	30.40	25.40	25.40	19.60	06
12.017	GH305.1010.125.00.08.R	5.00	10.00		125.00	10.00	20.00	24.00	25.00	8.20	08
12.018	GH305.1212.125.00.08.R	5.00	12.00		125.00	12.00	20.00	24.00	25.00	8.20	08
12.027	GH305.0625.500.00.08.R	5.00		5/8	127.00	15.87	20.87	25.40	25.40	8.07	08
12.007	GH305.1616.125.00.08.R	5.00	16.00		125.00	16.00	21.00	25.00	25.00	8.20	08
12.028	GH305.0750.500.00.08.R	5.00		3/4	127.00	19.05	24.05	25.40	25.40	11.25	08
12.008	GH305.2020.125.00.08.R	5.00	20.00		125.00	20.00	25.00	25.00	25.00	12.20	08
12.009	GH305.2525.150.00.08.R	5.00	25.00		150.00	25.00	30.00	25.00	25.00	17.20	08
12.029	GH305.1000.600.00.08.R	5.00		1"	152.40	25.40	30.40	25.40	25.40	17.60	08
12.019	GH305.1010.125.00.12.R	5.00	10.00		125.00	10.00	20.00	24.00	25.00	8.20	12
12.020	GH305.1212.125.00.12.R	5.00	12.00		125.00	12.00	20.00	24.00	25.00	8.20	12
12.030	GH305.0625.500.00.12.R	5.00		5/8	127.00	15.87	20.87	24.40	25.40	8.27	12
12.010	GH305.1616.125.00.12.R	5.00	16.00		125.00	16.00	21.00	24.00	25.00	8.60	12
12.031	GH305.0750.500.00.12.R	5.00		3/4	127.00	19.05	24.05	25.40	25.40	7.25	12
12.011	GH305.2020.125.00.12.R	5.00	20.00		125.00	20.00	25.00	25.00	25.00	8.20	12
12.012	GH305.2525.150.00.12.R	5.00	25.00		150.00	25.00	30.00	25.00	25.00	13.20	12
12.032	GH305.1000.600.00.12.R	5.00		1"	152.40	25.40	30.40	25.40	25.40	13.60	12

Series no. **25351**

version left-hand

Code no.	Description	t max	h=b	h=b	L	h1	H	l1	l2	f1	Size
		mm	mm	inch	mm	mm	mm	mm	mm	mm	
12.013	GH305.1010.125.00.04.L	5.00	10.00		125.00	10.00	20.00	24.00	25.00	8.20	04
12.014	GH305.1212.125.00.04.L	5.00	12.00		125.00	12.00	20.00	24.00	25.00	8.20	04
12.021	GH305.0625.500.00.04.L	5.00		5/8	127.00	15.87	20.87	25.40	25.40	12.07	04
12.001	GH305.1616.125.00.04.L	5.00	16.00		125.00	16.00	21.00	25.00	25.00	12.20	04
12.022	GH305.0750.500.00.04.L	5.00		3/4	127.00	19.05	24.05	25.40	25.40	15.25	04
12.002	GH305.2020.125.00.04.L	5.00	20.00		125.00	20.00	25.00	25.00	25.00	16.20	04
12.003	GH305.2525.150.00.04.L	5.00	25.00		150.00	25.00	30.00	25.00	25.00	21.20	04
12.023	GH305.1000.600.00.04.L	5.00		1"	152.40	25.40	30.40	25.40	25.40	21.60	04
12.015	GH305.1010.125.00.06.L	5.00	10.00		125.00	10.00	20.00	24.00	25.00	8.20	06
12.016	GH305.1212.125.00.06.L	5.00	12.00		125.00	12.00	20.00	24.00	25.00	8.20	06
12.024	GH305.0625.500.00.06.L	5.00		5/8	127.00	15.87	20.87	25.40	25.40	10.07	06
12.004	GH305.1616.125.00.06.L	5.00	16.00		125.00	16.00	21.00	25.00	25.00	10.20	06
12.025	GH305.0750.500.00.06.L	5.00		3/4	127.00	19.05	24.05	25.40	25.40	13.25	06
12.005	GH305.2020.125.00.06.L	5.00	20.00		125.00	20.00	25.00	25.00	25.00	14.20	06
12.006	GH305.2525.150.00.06.L	5.00	25.00		150.00	25.00	30.00	25.00	25.00	19.20	06
12.026	GH305.1000.600.00.06.L	5.00		1"	152.40	25.40	30.40	25.40	25.40	19.60	06
12.017	GH305.1010.125.00.08.L	5.00	10.00		125.00	10.00	20.00	24.00	25.00	8.20	08
12.018	GH305.1212.125.00.08.L	5.00	12.00		125.00	12.00	20.00	24.00	25.00	8.20	08
12.027	GH305.0625.500.00.08.L	5.00		5/8	127.00	15.87	20.87	25.40	25.40	8.07	08
12.007	GH305.1616.125.00.08.L	5.00	16.00		125.00	16.00	21.00	25.00	25.00	8.20	08
12.028	GH305.0750.500.00.08.L	5.00		3/4	127.00	19.05	24.05	25.40	25.40	11.25	08
12.008	GH305.2020.125.00.08.L	5.00	20.00		125.00	20.00	25.00	25.00	25.00	12.20	08
12.009	GH305.2525.150.00.08.L	5.00	25.00		150.00	25.00	30.00	25.00	25.00	17.20	08
12.029	GH305.1000.600.00.08.L	5.00		1"	152.40	25.40	30.40	25.40	25.40	17.60	08
12.019	GH305.1010.125.00.12.L	5.00	10.00		125.00	10.00	20.00	24.00	25.00	8.20	12
12.020	GH305.1212.125.00.12.L	5.00	12.00		125.00	12.00	20.00	24.00	25.00	8.20	12
12.030	GH305.0625.500.00.12.L	5.00		5/8	127.00	15.87	20.87	24.40	25.40	8.27	12
12.010	GH305.1616.125.00.12.L	5.00	16.00		125.00	16.00	21.00	24.00	25.00	8.60	12
12.031	GH305.0750.500.00.12.L	5.00		3/4	127.00	19.05	24.05	25.40	25.40	7.25	12
12.011	GH305.2020.125.00.12.L	5.00	20.00		125.00	20.00	25.00	25.00	25.00	8.20	12
12.012	GH305.2525.150.00.12.L	5.00	25.00		150.00	25.00	30.00	25.00	25.00	13.20	12
12.032	GH305.1000.600.00.12.L	5.00		1"	152.40	25.40	30.40	25.40	25.40	13.60	12

System 305

Spare parts

Series no.	Clamping screw	Tightening torque
25901		Nm
Code 4.000	M4x15x42x15IP	4-4.5

Series no.	Torx-Plus Wrench
25904	
Code 15.000	T15IP T-handle



Square shank holder straight, external machining, with IC

- grooving depth up to 5 mm
- with internal coolant delivery from above and below

Type GH 305

for indexable inserts type 305 see from page 137

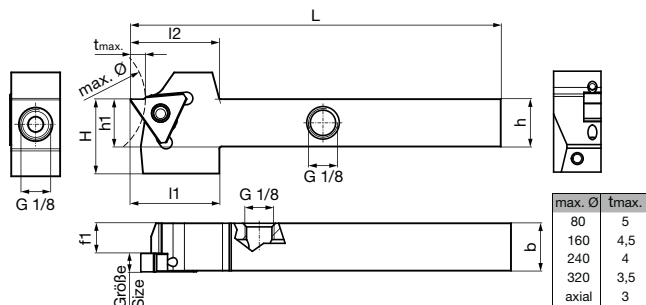

Right hand version shown
Left hand version mirror image

Series no. **25352**

version right-hand

Code no.	Description	t max	h=b	h=b	L	h1	H	l1	l2	f1	Size
		mm	mm	inch							
12.014	GH305.1212.125.00.04.R.IK	5.00	12.00		125.00	12.00	21.00	30.00	30.00	8.20	04
12.021	GH305.0625.500.00.04.R.IK	5.00		5/8	127.00	15.87	24.87	30.48	30.48	12.07	04
12.001	GH305.1616.125.00.04.R.IK	5.00	16.00		125.00	16.00	25.00	30.00	30.00	12.20	04
12.022	GH305.0750.500.00.04.R.IK	5.00		3/4	127.00	19.05	24.05	30.48	30.48	15.25	04
12.002	GH305.2020.125.00.04.R.IK	5.00	20.00		125.00	20.00	25.00	30.00	30.00	16.20	04
12.003	GH305.2525.150.00.04.R.IK	5.00	25.00		150.00	25.00	30.00	30.00	30.00	21.20	04
12.023	GH305.1000.600.00.04.R.IK	5.00		1"	152.40	25.40	30.40	30.48	30.48	21.60	04
12.016	GH305.1212.125.00.06.R.IK	5.00	12.00		125.00	12.00	21.00	30.00	30.00	6.20	06
12.024	GH305.0625.500.00.06.R.IK	5.00		5/8	127.00	15.87	24.87	30.48	30.48	10.07	06
12.004	GH305.1616.125.00.06.R.IK	5.00	16.00		125.00	16.00	25.00	30.00	30.00	10.20	06
12.025	GH305.0750.500.00.06.R.IK	5.00		3/4	127.00	19.05	24.05	30.48	30.48	13.25	06
12.005	GH305.2020.125.00.06.R.IK	5.00	20.00		125.00	20.00	25.00	30.00	30.00	14.20	06
12.006	GH305.2525.150.00.06.R.IK	5.00	25.00		150.00	25.00	30.00	30.00	30.00	19.20	06
12.026	GH305.1000.600.00.06.R.IK	5.00		1"	152.40	25.40	30.40	30.48	30.48	19.60	06
12.018	GH305.1212.125.00.08.R.IK	5.00	12.00		125.00	12.00	21.00	30.00	30.00	4.20	08
12.027	GH305.0625.500.00.08.R.IK	5.00		5/8	127.00	15.87	24.87	30.48	30.48	8.07	08
12.007	GH305.1616.125.00.08.R.IK	5.00	16.00		125.00	16.00	25.00	30.00	30.00	8.20	08
12.028	GH305.0750.500.00.08.R.IK	5.00		3/4	127.00	19.05	24.05	30.48	30.48	11.25	08
12.008	GH305.2020.125.00.08.R.IK	5.00	20.00		125.00	20.00	25.00	30.00	30.00	12.20	08
12.009	GH305.2525.150.00.08.R.IK	5.00	25.00		150.00	25.00	30.00	30.00	30.00	17.20	08
12.029	GH305.1000.600.00.08.R.IK	5.00		1"	152.40	25.40	30.40	30.48	30.48	17.60	08
12.020	GH305.1212.125.00.12.R.IK	5.00	12.00		125.00	12.00	25.00	30.00	30.00	0.20	12
12.030	GH305.0625.500.00.12.R.IK	5.00		5/8	127.00	15.87	24.87	30.48	30.48	4.07	12
12.010	GH305.1616.125.00.12.R.IK	5.00	16.00		125.00	16.00	25.00	30.00	30.00	4.20	12
12.031	GH305.0750.500.00.12.R.IK	5.00		3/4	127.00	19.05	24.05	30.48	30.48	7.25	12
12.011	GH305.2020.125.00.12.R.IK	5.00	20.00		125.00	20.00	25.00	30.00	30.00	8.20	12
12.012	GH305.2525.150.00.12.R.IK	5.00	25.00		150.00	25.00	30.00	30.00	30.00	13.20	12
12.032	GH305.1000.600.00.12.R.IK	5.00		1"	152.40	25.40	30.40	30.48	30.48	13.60	12

Series no. **25353**

version left-hand

Code no.	Description	t max	h=b	h=b	L	h1	H	l1	l2	f1	Size
		mm	mm	mm	mm	mm	mm	mm	mm	mm	
12.014	GH305.1212.125.00.04.L.IK	5.00	12.00		125.00	12.00	21.00	30.00	30.00	8.20	04
12.021	GH305.0625.500.00.04.L.IK	5.00		5/8	127.00	15.87	24.87	30.48	30.48	12.07	04
12.001	GH305.1616.125.00.04.L.IK	5.00	16.00		125.00	16.00	25.00	30.00	30.00	12.20	04
12.022	GH305.0750.500.00.04.L.IK	5.00		3/4	127.00	19.05	24.05	30.48	30.48	15.25	04
12.002	GH305.2020.125.00.04.L.IK	5.00	20.00		125.00	20.00	25.00	30.00	30.00	16.20	04
12.003	GH305.2525.150.00.04.L.IK	5.00	25.00		150.00	25.00	30.00	30.00	30.00	21.20	04
12.023	GH305.1000.600.00.04.L.IK	5.00		1"	152.40	25.40	30.40	30.48	30.48	21.60	04
12.016	GH305.1212.125.00.06.L.IK	5.00	12.00		125.00	12.00	21.00	30.00	30.00	6.20	06
12.024	GH305.0625.500.00.06.L.IK	5.00		5/8	127.00	15.87	24.87	30.48	30.48	10.07	06
12.004	GH305.1616.125.00.04.L.IK	5.00	16.00		125.00	16.00	25.00	30.00	30.00	10.20	06
12.025	GH305.0750.500.00.06.L.IK	5.00		3/4	127.00	19.05	24.05	30.48	30.48	13.25	06
12.005	GH305.2020.125.00.06.L.IK	5.00	20.00		125.00	20.00	25.00	30.00	30.00	14.20	06
12.006	GH305.2525.150.00.06.L.IK	5.00	25.00		150.00	25.00	30.00	30.00	30.00	19.20	06
12.026	GH305.1000.600.00.06.L.IK	5.00		1"	152.40	25.40	30.40	30.48	30.48	19.60	06
12.018	GH305.1212.125.00.08.L.IK	5.00	12.00		125.00	12.00	21.00	30.00	30.00	4.20	08
12.027	GH305.0625.500.00.08.L.IK	5.00		5/8	127.00	15.87	24.87	30.48	30.48	8.07	08
12.007	GH305.1616.125.00.08.L.IK	5.00	16.00		125.00	16.00	25.00	30.00	30.00	8.20	08
12.028	GH305.0750.500.00.08.L.IK	5.00		3/4	127.00	19.05	24.05	30.48	30.48	11.25	08
12.008	GH305.2020.125.00.08.L.IK	5.00	20.00		125.00	20.00	25.00	30.00	30.00	12.20	08
12.009	GH305.2525.150.00.08.L.IK	5.00	25.00		150.00	25.00	30.00	30.00	30.00	17.20	08
12.029	GH305.1000.600.00.08.L.IK	5.00		1"	152.40	25.40	30.40	30.48	30.48	17.60	08
12.020	GH305.1212.125.00.12.L.IK	5.00	12.00		125.00	12.00	25.00	30.00	30.00	0.20	12
12.030	GH305.0625.500.00.12.L.IK	5.00		5/8	127.00	15.87	24.87	30.48	30.48	4.07	12
12.010	GH305.1616.125.00.12.L.IK	5.00	16.00		125.00	16.00	25.00	30.00	30.00	4.20	12
12.031	GH305.0750.500.00.12.L.IK	5.00		3/4	127.00	19.05	24.05	30.48	30.48	7.25	12
12.011	GH305.2020.125.00.12.L.IK	5.00	20.00		125.00	20.00	25.00	30.00	30.00	8.20	12
12.012	GH305.2525.150.00.12.L.IK	5.00	25.00		150.00	25.00	30.00	30.00	30.00	13.20	12
12.032	GH305.1000.600.00.12.L.IK	5.00		1"	152.40	25.40	30.40	30.48	30.48	13.60	12

Spare parts

Series no.	Clamping screw	Tightening torque
25901		Nm
Code 4.000	M4x15x42x15IP	4-4.5

Series no.	Torx-Plus Wrench
25904	
Code 15.000	T15IP T-handle



Square shank holder straight, external machining, IC adjustable

- grooving depth up to 5 mm
- with internal coolant delivery

Type GH 305

for indexable inserts type 305 see from page 137

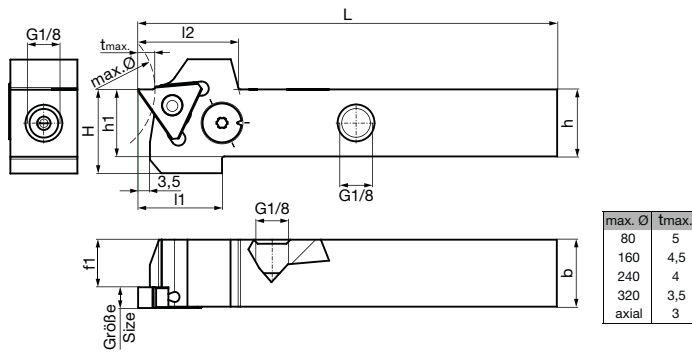

Right hand version shown
Left hand version mirror image

Series no. **25372**

version right-hand

Code no.	Description	t max	h	b	L	h1	H	l1	l2	f1	Size
		mm	mm	mm	mm	mm	mm	mm	mm	mm	
12.002	GH305.2020.125.00.04.R.IK.EST	5.00	20.00	20.00	125.00	20.00	25.00	30.00	30.00	16.20	04
12.003	GH305.2525.150.00.04.R.IK.EST	5.00	25.00	25.00	150.00	25.00	30.00	30.00	30.00	21.20	04
12.005	GH305.2020.125.00.06.R.IK.EST	5.00	20.00	20.00	125.00	20.00	25.00	30.00	30.00	14.20	06
12.006	GH305.2525.150.00.06.R.IK.EST	5.00	25.00	25.00	150.00	25.00	30.00	30.00	30.00	19.20	06

Series no. **25373**

version left-hand

Code no.	Description	t max	h	b	L	h1	H	l1	l2	f1	Size
		mm	mm	mm	mm	mm	mm	mm	mm	mm	
12.002	GH305.2020.125.00.04.L.IK.EST	5.00	20.00	20.00	125.00	20.00	25.00	30.00	30.00	16.20	04
12.003	GH305.2525.150.00.04.L.IK.EST	5.00	25.00	25.00	150.00	25.00	30.00	30.00	30.00	21.20	04
12.005	GH305.2020.125.00.06.L.IK.EST	5.00	20.00	20.00	125.00	20.00	25.00	30.00	30.00	14.20	06
12.006	GH305.2525.150.00.06.L.IK.EST	5.00	25.00	25.00	150.00	25.00	30.00	30.00	30.00	19.20	06

Spare parts

Series no.	Clamping screw	Tightening torque
25901		Nm
Code 4.000	M4x15x42x15IP	4-4.5

Series no.	Torx-Plus Wrench
25904	
Code 15.000	T15IP T-handle



Square shank holder 90° offset, external machining, without IC

- grooving depth up to 3.5 mm
- without internal coolant delivery

Type GH 305

for indexable inserts type 305 see from page 137

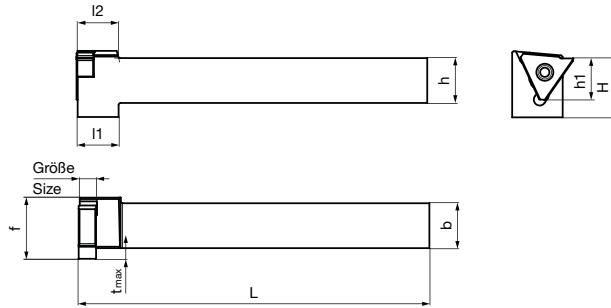

System 305

Right hand version shown
Left hand version mirror image

Series no. **25356**

version right-hand

Code no.	Description	t max	h=b	h=b	L	h1	H	l1	l2	f	Size
		mm	mm	inch		mm	mm				
12.013	GH305.1010.125.90.04.R	3.50	10.00		125.00	10.00	19.00	14.60	14.60	13.80	04
12.014	GH305.1212.125.90.04.R	3.50	12.00		125.00	12.00	21.00	14.60	14.60	15.80	04
12.021	GH305.0625.500.90.04.R	3.50		5/8	127.00	15.87	20.87	14.84	14.84	19.67	04
12.001	GH305.1616.125.90.04.R	3.50	16.00		125.00	16.00	21.00	14.60	14.60	19.80	04
12.022	GH305.0750.500.90.04.R	3.50		3/4	127.00	19.05	24.05	14.84	14.84	22.85	04
12.002	GH305.2020.125.90.04.R	3.50	20.00		125.00	20.00	25.00	14.60	14.60	23.80	04
12.003	GH305.2525.150.90.04.R	3.50	25.00		150.00	25.00	30.00	14.60	14.60	28.80	04
12.023	GH305.1000.600.90.04.R	3.50		1"	152.40	25.40	30.40	14.84	14.84	29.20	04
12.015	GH305.1010.125.90.06.R	3.50	10.00		125.00	10.00	19.00	14.60	14.60	13.80	06
12.016	GH305.1212.125.90.06.R	3.50	12.00		125.00	12.00	21.00	14.60	14.60	15.80	06
12.024	GH305.0625.500.90.06.R	3.50		5/8	127.00	15.87	20.87	14.84	14.84	19.67	06
12.004	GH305.1616.125.90.06.R	3.50	16.00		125.00	16.00	21.00	14.60	14.60	19.80	06
12.025	GH305.0750.500.90.06.R	3.50		3/4	127.00	19.05	24.05	14.84	14.84	22.85	06
12.005	GH305.2020.125.90.06.R	3.50	20.00		125.00	20.00	25.00	14.60	14.60	23.80	06
12.006	GH305.2525.150.90.06.R	3.50	25.00		150.00	25.00	30.00	14.60	14.60	28.80	06
12.026	GH305.1000.600.90.06.R	3.50		1"	152.40	25.40	30.40	14.84	14.84	29.20	06
12.017	GH305.1010.125.90.08.R	3.50	10.00		125.00	10.00	19.00	16.60	16.60	13.80	08
12.018	GH305.1212.125.90.08.R	3.50	12.00		125.00	12.00	21.00	16.60	16.60	15.80	08
12.027	GH305.0625.500.90.08.R	3.50		5/8	127.00	15.87	20.87	16.84	16.84	19.67	08
12.007	GH305.1616.125.90.08.R	3.50	16.00		125.00	16.00	21.00	16.60	16.60	19.80	08
12.028	GH305.0750.500.90.08.R	3.50		3/4	127.00	19.05	24.05	16.84	16.84	22.85	08
12.008	GH305.2020.125.90.08.R	3.50	20.00		125.00	20.00	25.00	16.60	16.60	23.80	08
12.009	GH305.2525.150.90.08.R	3.50	25.00		150.00	25.00	30.00	16.60	16.60	28.80	08
12.029	GH305.1000.600.90.08.R	3.50		1"	152.40	25.40	30.40	16.84	16.84	29.20	08
12.019	GH305.1010.125.90.12.R	3.50	10.00		125.00	10.00	19.00	16.60	20.60	13.80	12
12.020	GH305.1212.125.90.12.R	3.50	12.00		125.00	12.00	21.00	20.60	20.60	15.80	12
12.030	GH305.0625.500.90.12.R	3.50		5/8	127.00	15.87	20.87	20.84	20.84	19.67	12
12.010	GH305.1616.125.90.12.R	3.50	16.00		125.00	16.00	21.00	20.60	20.60	19.80	12
12.031	GH305.0750.500.90.12.R	3.50		3/4	127.00	19.05	24.05	20.84	20.84	22.85	12
12.011	GH305.2020.125.90.12.R	3.50	20.00		125.00	20.00	25.00	20.60	20.60	23.80	12
12.012	GH305.2525.150.90.12.R	3.50	25.00		150.00	25.00	30.00	20.60	20.60	28.80	12
12.032	GH305.1000.600.90.12.R	3.50		1"	152.40	25.40	30.40	20.84	20.84	29.20	12

Series no. **25357**

version left-hand

Code no.	Description	t max	h=b	h=b	L	h1	H	l1	l2	f	Size
		mm	mm	inch	mm	mm	mm	mm	mm	mm	
12.013	GH305.1010.125.90.04.L	3.50	10.00		125.00	10.00	19.00	14.60	14.60	13.80	04
12.014	GH305.1212.125.90.04.L	3.50	12.00		125.00	12.00	21.00	14.60	14.60	15.80	04
12.021	GH305.0625.500.90.04.L	3.50		5/8	127.00	15.87	20.87	14.84	14.84	19.67	04
12.001	GH305.1616.125.90.04.L	3.50	16.00		125.00	16.00	21.00	14.60	14.60	19.80	04
12.022	GH305.0750.500.90.04.L	3.50		3/4	127.00	19.05	24.05	14.84	14.84	22.85	04
12.002	GH305.2020.125.90.04.L	3.50	20.00		125.00	20.00	25.00	14.60	14.60	23.80	04
12.003	GH305.2525.150.90.04.L	3.50	25.00		150.00	25.00	30.00	14.60	14.60	28.80	04
12.023	GH305.1000.600.90.04.L	3.50		1"	152.40	25.40	30.40	14.84	14.84	29.20	04
12.015	GH305.1010.125.90.06.L	3.50	10.00		125.00	10.00	19.00	14.60	14.60	13.80	06
12.016	GH305.1212.125.90.06.L	3.50	12.00		125.00	12.00	21.00	14.60	14.60	15.80	06
12.024	GH305.0625.500.90.06.L	3.50		5/8	127.00	15.87	20.87	14.84	14.84	19.67	06
12.004	GH305.1616.125.90.06.L	3.50	16.00		125.00	16.00	21.00	14.60	14.60	19.80	06
12.025	GH305.0750.500.90.06.L	3.50		3/4	127.00	19.05	24.05	14.84	14.84	22.85	06
12.005	GH305.2020.125.90.06.L	3.50	20.00		125.00	20.00	25.00	14.60	14.60	23.80	06
12.006	GH305.2525.150.90.06.L	3.50	25.00		150.00	25.00	30.00	14.60	14.60	28.80	06
12.026	GH305.1000.600.90.06.L	3.50		1"	152.40	25.40	30.40	14.84	14.84	29.20	06
12.017	GH305.1010.125.90.08.L	3.50	10.00		125.00	10.00	19.00	16.60	16.60	13.80	08
12.018	GH305.1212.125.90.08.L	3.50	12.00		125.00	12.00	21.00	16.60	16.60	15.80	08
12.027	GH305.0625.500.90.08.L	3.50		5/8	127.00	15.87	20.87	16.84	16.84	19.67	08
12.007	GH305.1616.125.90.08.L	3.50	16.00		125.00	16.00	21.00	16.60	16.60	19.80	08
12.028	GH305.0750.500.90.08.L	3.50		3/4	127.00	19.05	24.05	16.84	16.84	22.85	08
12.008	GH305.2020.125.90.08.L	3.50	20.00		125.00	20.00	25.00	16.60	16.60	23.80	08
12.009	GH305.2525.150.90.08.L	3.50	25.00		150.00	25.00	30.00	16.60	16.60	28.80	08
12.029	GH305.1000.600.90.08.L	3.50		1"	152.40	25.40	30.40	16.84	16.84	29.20	08
12.019	GH305.1010.125.90.12.L	3.50	10.00		125.00	10.00	19.00	16.60	20.60	13.80	12
12.020	GH305.1212.125.90.12.L	3.50	12.00		125.00	12.00	21.00	20.60	20.60	15.80	12
12.030	GH305.0625.500.90.12.L	3.50		5/8	127.00	15.87	20.87	20.84	20.84	19.67	12
12.010	GH305.1616.125.90.12.L	3.50	16.00		125.00	16.00	21.00	20.60	20.60	19.80	12
12.031	GH305.0750.500.90.12.L	3.50		3/4	127.00	19.05	24.05	20.84	20.84	22.85	12
12.011	GH305.2020.125.90.12.L	3.50	20.00		125.00	20.00	25.00	20.60	20.60	23.80	12
12.012	GH305.2525.150.90.12.L	3.50	25.00		150.00	25.00	30.00	20.60	20.60	28.80	12
12.032	GH305.1000.600.90.12.L	3.50		1"	152.40	25.40	30.40	20.84	20.84	29.20	12

Spare parts

Series no.	Clamping screw	Tightening torque
25901		Nm
Code 4.000	M4x15x42x15IP	4-4.5

Series no.	Torx-Plus Wrench
25904	
Code 15.000	T15IP T-handle

System 305



Square shank holder 90° offset, external machining, with IC

- grooving depth up to 3.5 mm
- with internal coolant delivery from above and below

Type GH 305

for indexable inserts type 305 see from page 137

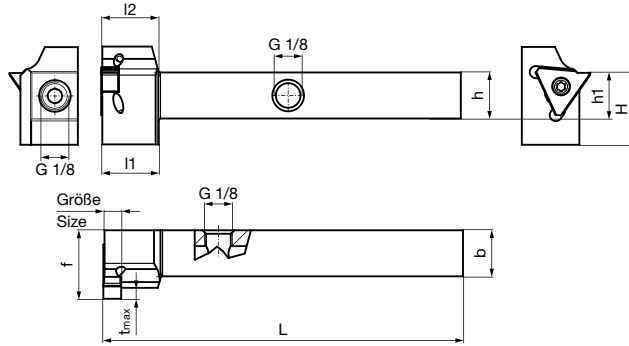

System 305

Right hand version shown
Left hand version mirror image

Series no. **25358**

version right-hand

Code no.	Description	t max	h=b	h=b	L	h1	H	l1	l2	f	Size
		mm	mm	inch	mm	mm	mm	mm	mm	mm	
12.014	GH305.1212.125.90.04.R.IK	3.50	12.00		125.00	12.00	21.00	21.60	21.60	23.80	04
12.021	GH305.0625.500.90.04.R.IK	3.50		5/8	127.00	15.87	24.87	19.92	19.92	24.12	04
12.001	GH305.1616.125.90.04.R.IK	3.50	16.00		125.00	16.00	25.00	19.60	19.60	23.80	04
12.022	GH305.0750.500.90.04.R.IK	3.50		3/4	127.00	19.05	24.05	19.92	19.92	22.85	04
12.002	GH305.2020.125.90.04.R.IK	3.50	20.00		125.00	20.00	25.00	19.60	19.60	23.80	04
12.003	GH305.2525.150.90.04.R.IK	3.50	25.00		150.00	25.00	30.00	19.60	19.60	28.80	04
12.023	GH305.1000.600.90.04.R.IK	3.50		1"	152.40	25.40	30.40	19.92	19.92	29.20	04
12.016	GH305.1212.125.90.06.R.IK	3.50	12.00		125.00	12.00	21.00	21.60	21.60	23.80	06
12.024	GH305.0625.500.90.06.R.IK	3.50		5/8	127.00	15.87	24.87	19.92	19.92	24.12	06
12.004	GH305.1616.125.90.06.R.IK	3.50	16.00		125.00	16.00	25.00	19.60	19.60	23.80	06
12.025	GH305.0750.500.90.06.R.IK	3.50		3/4	127.00	19.05	24.05	19.92	19.92	22.85	06
12.005	GH305.2020.125.90.06.R.IK	3.50	20.00		125.00	20.00	25.00	19.60	19.60	23.80	06
12.006	GH305.2525.150.90.06.R.IK	3.50	25.00		150.00	25.00	30.00	19.60	19.60	28.80	06
12.026	GH305.1000.600.90.06.R.IK	3.50		1"	152.40	25.40	30.40	19.92	19.92	29.20	06
12.018	GH305.1212.125.90.08.R.IK	3.50	12.00		125.00	12.00	21.00	23.60	23.60	23.80	08
12.027	GH305.0625.500.90.08.R.IK	3.50		5/8	127.00	15.87	24.87	21.92	21.92	24.12	08
12.007	GH305.1616.125.90.08.R.IK	3.50	16.00		125.00	16.00	25.00	19.60	19.60	23.80	08
12.028	GH305.0750.500.90.08.R.IK	3.50		3/4	127.00	19.05	24.05	19.92	19.92	22.85	08
12.008	GH305.2020.125.90.08.R.IK	3.50	20.00		125.00	20.00	25.00	19.60	19.60	23.80	08
12.009	GH305.2525.150.90.08.R.IK	3.50	25.00		150.00	25.00	30.00	19.60	19.60	28.80	08
12.029	GH305.1000.600.90.08.R.IK	3.50		1"	152.40	25.40	30.40	19.92	19.92	29.20	08
12.020	GH305.1212.125.90.12.R.IK	3.50	12.00		125.00	12.00	21.00	27.60	27.60	23.80	12
12.030	GH305.0625.500.90.12.R.IK	3.50		5/8	127.00	15.87	24.87	25.92	25.92	24.12	12
12.010	GH305.1616.125.90.12.R.IK	3.50	16.00		125.00	16.00	25.00	27.60	27.60	23.80	12
12.031	GH305.0750.500.90.12.R.IK	3.50		3/4	127.00	19.05	24.05	25.92	25.92	24.12	12
12.011	GH305.2020.125.90.12.R.IK	3.50	20.00		125.00	20.00	25.00	27.60	27.60	23.80	12
12.012	GH305.2525.150.90.12.R.IK	3.50	25.00		150.00	25.00	30.00	27.60	27.60	28.80	12
12.032	GH305.1000.600.90.12.R.IK	3.50		1"	152.40	25.40	30.40	25.92	25.92	29.20	12



Code no.	Description	t max	h=b	h=b	L	h1	H	l1	l2	f	Size
		mm	mm	inch	mm	mm	mm	mm	mm	mm	
12.014	GH305.1212.125.90.04.L.IK	3.50	12.00		125.00	12.00	21.00	21.60	21.60	23.80	04
12.021	GH305.0625.500.90.04.L.IK	3.50		5/8	127.00	15.87	24.87	19.92	19.92	24.12	04
12.001	GH305.1616.125.90.04.L.IK	3.50	16.00		125.00	16.00	25.00	19.60	19.60	23.80	04
12.022	GH305.0750.500.90.04.L.IK	3.50		3/4	127.00	19.05	24.05	19.92	19.92	22.85	04
12.002	GH305.2020.125.90.04.L.IK	3.50	20.00		125.00	20.00	25.00	19.60	19.60	23.80	04
12.003	GH305.2525.150.90.04.L.IK	3.50	25.00		150.00	25.00	30.00	19.60	19.60	28.80	04
12.023	GH305.1000.600.90.04.L.IK	3.50		1"	152.40	25.40	30.40	19.92	19.92	29.20	04
12.016	GH305.1212.125.90.06.L.IK	3.50	12.00		125.00	12.00	21.00	21.60	21.60	23.80	06
12.024	GH305.0625.500.90.06.L.IK	3.50		5/8	127.00	15.87	24.87	19.92	19.92	24.12	06
12.004	GH305.1616.125.90.06.L.IK	3.50	16.00		125.00	16.00	25.00	19.60	19.60	23.80	06
12.025	GH305.0750.500.90.06.L.IK	3.50		3/4	127.00	19.05	24.05	19.92	19.92	22.85	06
12.005	GH305.2020.125.90.06.L.IK	3.50	20.00		125.00	20.00	25.00	19.60	19.60	23.80	06
12.006	GH305.2525.150.90.06.L.IK	3.50	25.00		150.00	25.00	30.00	19.60	19.60	28.80	06
12.026	GH305.1000.600.90.06.L.IK	3.50		1"	152.40	25.40	30.40	19.92	19.92	29.20	06
12.018	GH305.1212.125.90.08.L.IK	3.50	12.00		125.00	12.00	21.00	23.60	23.60	23.80	08
12.027	GH305.0625.500.90.08.L.IK	3.50		5/8	127.00	15.87	24.87	21.92	21.92	24.12	08
12.007	GH305.1616.125.90.08.L.IK	3.50	16.00		125.00	16.00	25.00	19.60	19.60	23.80	08
12.028	GH305.0750.500.90.08.L.IK	3.50		3/4	127.00	19.05	24.05	19.92	19.92	22.85	08
12.008	GH305.2020.125.90.08.L.IK	3.50	20.00		125.00	20.00	25.00	19.60	19.60	23.80	08
12.009	GH305.2525.150.90.08.L.IK	3.50	25.00		150.00	25.00	30.00	19.60	19.60	28.80	08
12.029	GH305.1000.600.90.08.L.IK	3.50		1"	152.40	25.40	30.40	19.92	19.92	29.20	08
12.020	GH305.1212.125.90.12.L.IK	3.50	12.00		125.00	12.00	21.00	27.60	27.60	23.80	12
12.030	GH305.0625.500.90.12.L.IK	3.50		5/8	127.00	15.87	24.87	25.92	25.92	24.12	12
12.010	GH305.1616.125.90.12.L.IK	3.50	16.00		125.00	16.00	25.00	27.60	27.60	23.80	12
12.031	GH305.0750.500.90.12.L.IK	3.50		3/4	127.00	19.05	24.05	25.92	25.92	24.12	12
12.011	GH305.2020.125.90.12.L.IK	3.50	20.00		125.00	20.00	25.00	27.60	27.60	23.80	12
12.012	GH305.2525.150.90.12.L.IK	3.50	25.00		150.00	25.00	30.00	27.60	27.60	28.80	12
12.032	GH305.1000.600.90.12.L.IK	3.50		1"	152.40	25.40	30.40	25.92	25.92	29.20	12

Spare parts

Series no.	Clamping screw	Tightening torque
25901		Nm
Code 4.000	M4x15x42x15IP	4-4.5

Series no.	Torx-Plus Wrench
25904	
Code 15.000	T15IP T-handle



Square shank holder 45° offset, external machining, without IC

- grooving depth up to 2 mm
- without internal coolant delivery

Type GH 305

for indexable inserts type 305 see page 137

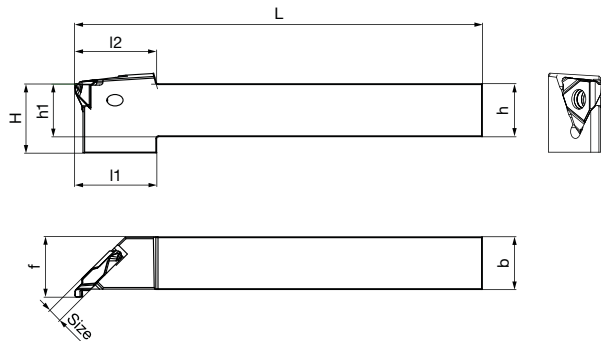

System 305

Right hand version shown
Left hand version mirror image

Series no. **25362**
version right-hand

Code no.	Description	h=b	h=b	L	h1	H	l1	l2	f	Size
		mm	inch	mm	mm	mm	mm	mm	mm	
12.004	GH305.1010.125.45.04.R	10.00		125.00	10.00	21.00	25.66	25.66	12.56	04
12.005	GH305.1212.125.45.04.R	12.00		125.00	12.00	21.00	25.66	25.66	14.56	04
12.021	GH305.0625.500.45.04.R		5/8	127.00	15.87	20.87	26.06	26.06	18.44	04
12.001	GH305.1616.125.45.04.R	16.00		125.00	16.00	21.00	25.66	25.66	18.56	04
12.022	GH305.0750.500.45.04.R		3/4	127.00	19.05	24.05	26.06	26.06	21.61	04
12.002	GH305.2020.125.45.04.R	20.00		125.00	20.00	25.00	25.66	25.66	22.56	04
12.003	GH305.2525.150.45.04.R	25.00		150.00	25.00	30.00	30.66	30.66	27.56	04
12.023	GH305.1000.600.45.04.R		1"	152.40	25.40	30.40	31.14	31.14	27.96	04

Series no. **25363**
version left-hand

Code no.	Description	h=b	h=b	L	h1	H	l1	l2	f	Size
		mm	inch	mm	mm	mm	mm	mm	mm	
12.004	GH305.1010.125.45.04.L	10.00		125.00	10.00	21.00	25.66	25.66	12.56	04
12.005	GH305.1212.125.45.04.L	12.00		125.00	12.00	21.00	25.66	25.66	14.56	04
12.021	GH305.0625.500.45.04.L		5/8	127.00	15.87	20.87	26.06	26.06	18.44	04
12.001	GH305.1616.125.45.04.L	16.00		125.00	16.00	21.00	25.66	25.66	18.56	04
12.022	GH305.0750.500.45.04.L		3/4	127.00	19.05	24.05	26.06	26.06	21.61	04
12.002	GH305.2020.125.45.04.L	20.00		125.00	20.00	25.00	25.66	25.66	22.56	04
12.003	GH305.2525.150.45.04.L	25.00		150.00	25.00	30.00	30.66	30.66	27.56	04
12.023	GH305.1000.600.45.04.L		1"	152.40	25.40	30.40	31.14	31.14	27.96	04

Spare parts

Series no.	Clamping screw	Tightening torque
25902		Nm
Code 4.001	M4x0.5x7x42x15IP	3-3.5

Series no.	Torx-Plus Wrench
25904	
Code 15.000	T15IP T-handle



Square shank holder 45° offset, external machining, with IC

- grooving depth up to 2 mm
- with internal coolant delivery from above

Type GH 305

for indexable inserts type 305 see page 137

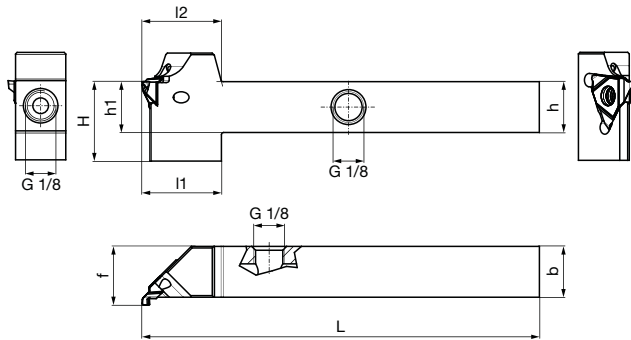

Right hand version shown
Left hand version mirror image

Series no. **25364**

version right-hand

Code no.	Description	h=b	h=b	L	h1	H	l1	l2	f	Size
		mm	inch							
12.005	GH305.1212.125.45.04.R.IK	12.00		125.00	12.00	25.00	25.66	25.66	14.56	04
12.021	GH305.0625.500.45.04.R.IK		5/8	127.00	15.87	24.87	26.06	26.06	18.44	04
12.001	GH305.1616.125.45.04.R.IK	16.00		125.00	16.00	25.00	25.66	25.66	18.56	04
12.022	GH305.0750.500.45.04.R.IK		3/4	127.00	19.05	24.05	26.06	26.06	21.61	04
12.002	GH305.2020.125.45.04.R.IK	20.00		125.00	20.00	25.00	25.66	25.66	22.56	04
12.003	GH305.2525.150.45.04.R.IK	25.00		150.00	25.00	30.00	30.66	30.66	27.56	04
12.023	GH305.1000.600.45.04.R.IK		1"	152.40	25.40	30.40	31.14	31.14	27.96	04

Series no. **25365**

version left-hand

Code no.	Description	h=b	h=b	L	h1	H	l1	l2	f	Size
		mm	inch							
12.005	GH305.1212.125.45.04.L.IK	12.00		125.00	12.00	25.00	25.66	25.66	14.56	04
12.021	GH305.0625.500.45.04.L.IK		5/8	127.00	15.87	24.87	26.06	26.06	18.44	04
12.001	GH305.1616.125.45.04.L.IK	16.00		125.00	16.00	25.00	25.66	25.66	18.56	04
12.022	GH305.0750.500.45.04.L.IK		3/4	127.00	19.05	24.05	26.06	26.06	21.61	04
12.002	GH305.2020.125.45.04.L.IK	20.00		125.00	20.00	25.00	25.66	25.66	22.56	04
12.003	GH305.2525.150.45.04.L.IK	25.00		150.00	25.00	30.00	30.66	30.66	27.56	04
12.023	GH305.1000.600.45.04.L.IK		1"	152.40	25.40	30.40	31.14	31.14	27.96	04

Spare parts

Series no.	Clamping screw	Tightening torque
25902		Nm
Code 4.001	M4x0.5x7x42x15IP	3-3.5

Series no.	Torx-Plus Wrench
25904	
Code 15.000	T15IP T-handle



Round shank holder, internal machining, without IC

- grooving depth up to 4 mm
- without internal coolant delivery

Type GB 305

for indexable inserts type 305 see from page 137

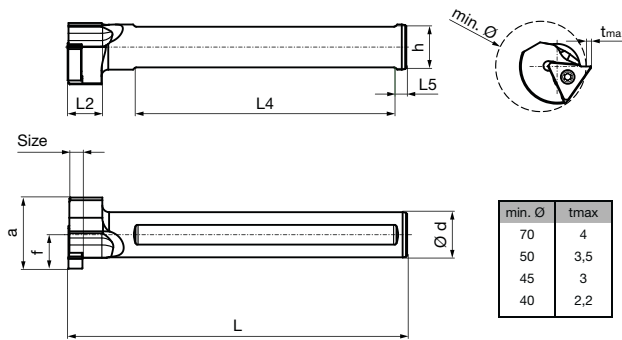

Right hand version shown
Left hand version mirror image



System 305

Series no. **25368**

version right-hand

Code no.	Description	d	d	L	L2	L4	L5	h	f	a	Size
		mm	inch	mm	mm	mm	mm	mm	mm	mm	
12.021	GB305.0750.600.90.04.R		3/4	152.40	14.60	116.84	5.08	17.04	14.48	30.48	04
12.001	GB305.0020.150.90.04.R	20.00		150.00	14.60	115.00	5.00	18.00	15.00	31.50	04
12.002	GB305.0025.170.90.04.R	25.00		170.00	14.60	130.00	5.00	23.00	17.50	34.50	04
12.022	GB305.1000.670.90.04.R		1"	170.18	14.60	129.54	5.08	23.39	17.78	34.54	04
12.023	GB305.1250.800.90.04.R		1-1/4	205.20	14.60	162.56	5.08	29.74	21.08	39.37	04
12.003	GB305.0032.200.90.04.R	32.00		200.00	14.60	160.00	5.00	30.00	21.00	39.25	04
12.024	GB305.0750.600.90.06.R		3/4	152.40	14.60	116.84	5.08	17.04	14.48	30.48	06
12.004	GB305.0020.150.90.06.R	20.00		150.00	14.60	115.00	5.00	18.00	15.00	31.50	06
12.005	GB305.0025.170.90.06.R	25.00		170.00	14.60	130.00	5.00	23.00	17.50	34.50	06
12.025	GB305.1000.670.90.06.R		1"	170.18	14.60	129.54	5.08	23.39	17.78	34.54	06
12.026	GB305.1250.800.90.06.R		1-1/4	203.20	14.60	162.56	5.08	29.74	21.08	39.37	06
12.006	GB305.0032.200.90.06.R	32.00		200.00	14.60	160.00	5.00	30.00	21.00	39.25	06
12.027	GB305.0750.600.90.08.R		3/4	152.40	14.60	116.84	5.08	17.04	14.48	30.48	08
12.007	GB305.0020.150.90.08.R	20.00		150.00	14.60	115.00	5.00	18.00	15.00	31.50	08
12.008	GB305.0025.170.90.08.R	25.00		170.00	14.60	130.00	5.00	23.00	17.50	34.50	08
12.028	GB305.1000.670.90.08.R		1"	170.18	14.60	129.54	5.08	23.39	17.78	34.54	08
12.029	GB305.1250.800.90.08.R		1-1/4	203.20	14.60	162.56	5.08	29.74	21.08	39.37	08
12.009	GB305.0032.200.90.08.R	32.00		200.00	14.60	160.00	5.00	30.00	21.00	39.25	08
12.030	GB305.0750.600.90.12.R		3/4	152.40	19.60	116.84	5.08	17.04	14.48	30.48	12
12.010	GB305.0020.150.90.12.R	20.00		150.00	19.60	115.00	5.00	18.00	15.00	31.50	12
12.011	GB305.0025.170.90.12.R	25.00		170.00	19.60	130.00	5.00	23.00	17.50	34.50	12
12.031	GB305.1000.670.90.12.R		1"	170.18	19.60	129.54	5.08	23.39	17.78	34.54	12
12.032	GB305.1250.800.90.12.R		1-1/4	203.20	19.60	162.56	5.08	29.74	21.08	39.37	12
12.012	GB305.0032.200.90.12.R	32.00		200.00	19.60	160.00	5.00	30.00	21.00	39.25	12

Series no. **25369**

version left-hand

Code no.	Description	d	d	L	L2	L4	L5	h	f	a	Size
		mm	inch	mm	mm	mm	mm	mm	mm	mm	
12.021	GB305.0750.600.90.04.L		3/4	152.40	14.60	116.84	5.08	17.04	14.48	30.48	04
12.001	GB305.0020.150.90.04.L	20.00		150.00	14.60	115.00	5.00	18.00	15.00	31.50	04
12.002	GB305.0025.170.90.04.L	25.00		170.00	14.60	130.00	5.00	23.00	17.50	34.50	04
12.022	GB305.1000.670.90.04.L		1"	170.18	14.60	129.54	5.08	23.39	17.78	34.54	04
12.023	GB305.1250.800.90.04.L		1-1/4	205.20	14.60	162.56	5.08	29.74	21.08	39.37	04
12.003	GB305.0032.200.90.04.L	32.00		200.00	14.60	160.00	5.00	30.00	21.00	39.25	04

Series no. **25369**

version left-hand

Code no.	Description	d	d	L	L2	L4	L5	h	f	a	Size
		mm	inch	mm	mm	mm	mm	mm	mm	mm	
12.024	GB305.0750.600.90.06.L		3/4	152.40	14.60	116.84	5.08	17.04	14.48	30.48	06
12.004	GB305.0020.150.90.06.L	20.00		150.00	14.60	115.00	5.00	18.00	15.00	31.50	06
12.005	GB305.0025.170.90.06.L	25.00		170.00	14.60	130.00	5.00	23.00	17.50	34.50	06
12.025	GB305.1000.670.90.06.L		1"	170.18	14.60	129.54	5.08	23.39	17.78	34.54	06
12.026	GB305.1250.800.90.06.L		1-1/4	203.20	14.60	162.56	5.08	29.74	21.08	39.37	06
12.006	GB305.0032.200.90.06.L	32.00		200.00	14.60	160.00	5.00	30.00	21.00	39.25	06
12.027	GB305.0750.600.90.08.L		3/4	152.40	14.60	116.84	5.08	17.04	14.48	30.48	08
12.007	GB305.0020.150.90.08.L	20.00		150.00	14.60	115.00	5.00	18.00	15.00	31.50	08
12.008	GB305.0025.170.90.08.L	25.00		170.00	14.60	130.00	5.00	23.00	17.50	34.50	08
12.028	GB305.1000.670.90.08.L		1"	170.18	14.60	129.54	5.08	23.39	17.78	34.54	08
12.029	GB305.1250.800.90.08.L		1-1/4	203.20	14.60	162.56	5.08	29.74	21.08	39.37	08
12.009	GB305.0032.200.90.08.L	32.00		200.00	14.60	160.00	5.00	30.00	21.00	39.25	08
12.030	GB305.0750.600.90.12.L		3/4	152.40	19.60	116.84	5.08	17.04	14.48	30.48	12
12.010	GB305.0020.150.90.12.L	20.00		150.00	19.60	115.00	5.00	18.00	15.00	31.50	12
12.011	GB305.0025.170.90.12.L	25.00		170.00	19.60	130.00	5.00	23.00	17.50	34.50	12
12.031	GB305.1000.670.90.12.L		1"	170.18	19.60	129.54	5.08	23.39	17.78	34.54	12
12.032	GB305.1250.800.90.12.L		1-1/4	203.20	19.60	162.56	5.08	29.74	21.08	39.37	12
12.012	GB305.0032.200.90.12.L	32.00		200.00	19.60	160.00	5.00	30.00	21.00	39.25	12

Spare parts

Series no.	Clamping screw	Tightening torque
25901		Nm
Code 4.000	M4x15x42x15IP	4-4.5

Series no.	Torx-Plus Wrench
25904	
Code 15.000	T15IP T-handle



Round shank holder, internal machining, with IC

- grooving depth up to 4 mm
- with internal coolant delivery from above

Type GB 305

for indexable inserts type 305 see from page 137

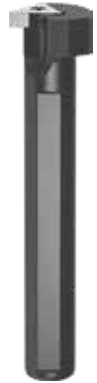
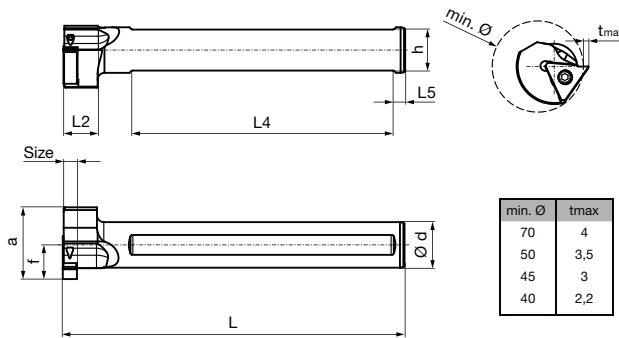

System 305

Right hand version shown
Left hand version mirror image

Series no. **25370**
version right-hand

Code no.	Description	d		L	L2	L4	L5	h	f	a	Size
		mm	inch								
12.021	GB305.0750.600.90.04.R.IK		3/4	152.40	14.60	116.84	5.08	17.04	14.48	30.48	04
12.001	GB305.0020.150.90.04.R.IK	20.00		150.00	14.60	115.00	5.00	18.00	15.00	31.50	04
12.002	GB305.0025.170.90.04.R.IK	25.00		170.00	14.60	130.00	5.00	23.00	17.50	34.50	04
12.022	GB305.1000.670.90.04.R.IK		1"	170.18	14.60	129.54	5.08	23.39	17.78	34.54	04
12.023	GB305.1250.800.90.04.R.IK		1-1/4	205.20	14.60	162.56	5.08	29.74	21.08	39.37	04
12.003	GB305.0032.200.90.04.R.IK	32.00		200.00	14.60	160.00	5.00	30.00	21.00	39.25	04
12.024	GB305.0750.600.90.06.R.IK		3/4	152.40	14.60	116.84	5.08	17.04	14.48	30.48	06
12.004	GB305.0020.150.90.06.R.IK	20.00		150.00	14.60	115.00	5.00	18.00	15.00	31.50	06
12.005	GB305.0025.170.90.06.R.IK	25.00		170.00	14.60	130.00	5.00	23.00	17.50	34.50	06
12.025	GB305.1000.670.90.06.R.IK		1"	170.18	14.60	129.54	5.08	23.39	17.78	34.54	06
12.026	GB305.1250.800.90.06.R.IK		1-1/4	203.20	14.60	162.56	5.08	29.74	21.08	39.37	06
12.006	GB305.0032.200.90.06.R.IK	32.00		200.00	14.60	160.00	5.00	30.00	21.00	39.25	06
12.027	GB305.0750.600.90.12.R.IK		3/4	152.40	14.60	116.84	5.08	17.04	14.48	30.48	08
12.007	GB305.0020.150.90.08.R.IK	20.00		150.00	14.60	115.00	5.00	18.00	15.00	31.50	08
12.008	GB305.0025.170.90.08.R.IK	25.00		170.00	14.60	130.00	5.00	23.00	17.50	34.50	08
12.028	GB305.1000.670.90.08.R.IK		1"	170.18	14.60	129.54	5.08	23.39	17.78	34.54	08
12.029	GB305.1250.800.90.08.R.IK		1-1/4	203.20	14.60	162.56	5.08	29.74	21.08	39.37	08
12.009	GB305.0032.200.90.08.R.IK	32.00		200.00	14.60	160.00	5.00	30.00	21.00	39.25	08
12.030	GB305.0750.600.90.06.R.IK		3/4	152.40	19.60	116.84	5.08	17.04	14.48	30.48	12
12.010	GB305.0020.150.90.12.R.IK	20.00		150.00	19.60	115.00	5.00	18.00	15.00	31.50	12
12.011	GB305.0025.170.90.12.R.IK	25.00		170.00	19.60	130.00	5.00	23.00	17.50	34.50	12
12.031	GB305.1000.670.90.12.R.IK		1"	170.18	19.60	129.54	5.08	23.39	17.78	34.54	12
12.032	GB305.1250.800.90.12.R.IK		1-1/4	203.20	19.60	162.56	5.08	29.74	21.08	39.37	12
12.012	GB305.0032.200.90.12.R.IK	32.00		200.00	19.60	160.00	5.00	30.00	21.00	39.25	12

Series no. **25371**

version left-hand

Code no.	Description	d	d	L	L2	L4	L5	h	f	a	Size
		mm	inch	mm	mm	mm	mm	mm	mm	mm	
12.021	GB305.0750.600.90.04.L.IK		3/4	152.40	14.60	116.84	5.08	17.04	14.48	30.48	04
12.001	GB305.0020.150.90.04.L.IK	20.00		150.00	14.60	115.00	5.00	18.00	15.00	31.50	04
12.002	GB305.0025.170.90.04.L.IK	25.00		170.00	14.60	130.00	5.00	23.00	17.50	34.50	04
12.022	GB305.1000.670.90.04.L.IK		1"	170.18	14.60	129.54	5.08	23.39	17.78	34.54	04
12.023	GB305.1250.800.90.04.L.IK		1-1/4	205.20	14.60	162.56	5.08	29.74	21.08	39.37	04
12.003	GB305.0032.200.90.04.L.IK	32.00		200.00	14.60	160.00	5.00	30.00	21.00	39.25	04
12.024	GB305.0750.600.90.06.L.IK		3/4	152.40	14.60	116.84	5.08	17.04	14.48	30.48	06
12.004	GB305.0020.150.90.06.L.IK	20.00		150.00	14.60	115.00	5.00	18.00	15.00	31.50	06
12.005	GB305.0025.170.90.06.L.IK	25.00		170.00	14.60	130.00	5.00	23.00	17.50	34.50	06
12.025	GB305.1000.670.90.06.L.IK		1"	170.18	14.60	129.54	5.08	23.39	17.78	34.54	06
12.026	GB305.1250.800.90.06.L.IK		1-1/4	203.20	14.60	162.56	5.08	29.74	21.08	39.37	06
12.006	GB305.0032.200.90.06.L.IK	32.00		200.00	14.60	160.00	5.00	30.00	21.00	39.25	06
12.027	GB305.0750.600.90.12.L.IK		3/4	152.40	14.60	116.84	5.08	17.04	14.48	30.48	08
12.007	GB305.0020.150.90.08.L.IK	20.00		150.00	14.60	115.00	5.00	18.00	15.00	31.50	08
12.008	GB305.0025.170.90.08.L.IK	25.00		170.00	14.60	130.00	5.00	23.00	17.50	34.50	08
12.028	GB305.1000.670.90.08.L.IK		1"	170.18	14.60	129.54	5.08	23.39	17.78	34.54	08
12.029	GB305.1250.800.90.08.L.IK		1-1/4	203.20	14.60	162.56	5.08	29.74	21.08	39.37	08
12.009	GB305.0032.200.90.08.L.IK	32.00		200.00	14.60	160.00	5.00	30.00	21.00	39.25	08
12.030	GB305.0750.600.90.06.L.IK		3/4	152.40	19.60	116.84	5.08	17.04	14.48	30.48	12
12.010	GB305.0020.150.90.12.L.IK	20.00		150.00	19.60	115.00	5.00	18.00	15.00	31.50	12
12.011	GB305.0025.170.90.12.L.IK	25.00		170.00	19.60	130.00	5.00	23.00	17.50	34.50	12
12.031	GB305.1000.670.90.12.L.IK		1"	170.18	19.60	129.54	5.08	23.39	17.78	34.54	12
12.032	GB305.1250.800.90.12.L.IK		1-1/4	203.20	19.60	162.56	5.08	29.74	21.08	39.37	12
12.012	GB305.0032.200.90.12.L.IK	32.00		200.00	19.60	160.00	5.00	30.00	21.00	39.25	12

Spare parts

Series no.	Clamping screw	Tightening torque
25901		Nm
Code 4.000	M4x15x42x15IP	4-4.5

Series no.	Torx-Plus Wrench
25904	
Code 15.000	T15IP T-handle



Indexable insert for radial grooving external and internal

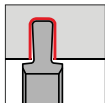

- Snap ring grooves to DIN471/472, NW = 0.5-5.15
- Indexable insert applicable in right and left holders
- Geometry .BA ground
- Pay attention to insert seat size 04 / 06

for tool holders type GH305/GB305 see from page 122

Tool material	Solid carbide		
Type	GE 305	GE 305	GE 305
Surface	F	C	○
	FIRE	TiCN	bright

Cutting data page 149

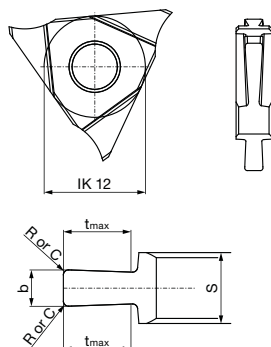

Series no. **25601** **25602** **25603**

Code no.	Description	NW	b ± 0.02	R	C	t max	s	Size
		mm	mm	mm	mm	mm	mm	
12.001	GE305.0050.000.BA.04.N	0.50	0.55			1.50	4.20	04
12.002	GE305.0060.000.BA.04.N	0.60	0.65			1.50	4.20	04
12.003	GE305.0070.000.BA.04.N	0.70	0.75			1.50	4.20	04
12.004	GE305.0080.000.BA.04.N	0.80	0.85			1.50	4.20	04
12.005	GE305.0090.000.BA.04.N	0.90	0.95			1.50	4.20	04
12.006	GE305.0100.000.BA.04.N	1.00	1.05		0.05	3.00	4.20	04
12.007	GE305.0110.000.BA.04.N	1.10	1.22		0.05	3.00	4.20	04
12.008	GE305.0130.000.BA.04.N	1.30	1.42		0.05	3.00	4.20	04
12.009	GE305.0160.000.BA.04.N	1.60	1.72		0.05	4.00	4.20	04
12.010	GE305.0185.015.BA.04.N	1.85	1.97	0.15		4.00	4.20	04
12.011	GE305.0215.015.BA.04.N	2.15	2.27	0.15		5.00	4.20	04
12.012	GE305.0265.015.BA.04.N	2.65	2.77	0.15		5.00	4.20	04
12.013	GE305.0315.015.BA.04.N	3.15	3.27	0.15		5.00	4.20	04
12.014	GE305.0415.015.BA.06.N	4.15	4.27	0.15		5.00	6.20	06
12.015	GE305.0515.015.BA.06.N	5.15	5.27	0.15		5.00	6.20	06

System 305



Indexable insert for radial grooving and copying external and internal

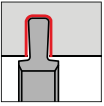

- grooving depth up to 5 mm
- Indexable insert applicable in right and left holders
- Geometry .BA ground

for tool holders type GH305/GB305 size 04 see from page 122

Tool material	Solid carbide		
Type	GE 305	GE 305	GE 305
Surface	F	C	○
	FIRE	TiCN	bright

Cutting data page 149

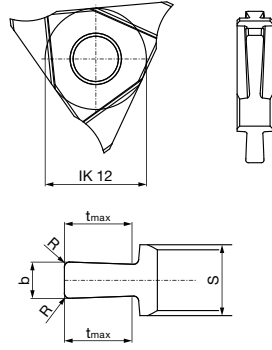

Series no. **25605** **25606** **25607**

Code no.	Description	b ± 0.02	R	t max	s	Size
		mm	mm	mm	mm	
12.001	GE305.0100.010.BA.04.N	1.00	0.10	3.00	4.20	04
12.002	GE305.0150.020.BA.04.N	1.50	0.20	3.00	4.20	04
12.003	GE305.0200.020.BA.04.N	2.00	0.20	4.00	4.20	04
12.004	GE305.0250.030.BA.04.N	2.50	0.30	5.00	4.20	04
12.005	GE305.0300.030.BA.04.N	3.00	0.30	5.00	4.20	04
12.006	GE305.0350.030.BA.04.N	3.50	0.30	5.00	4.20	04
12.007	GE305.0400.020.BA.04.N	4.00	0.20	5.00	4.20	04
12.008	GE305.0400.040.BA.04.N	4.00	0.40	5.00	4.20	04



Indexable insert for radial grooving and copying external and internal

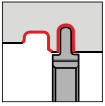

- grooving depth up to 5 mm
- Indexable insert applicable in right and left holders
- Geometry .AA ground

for tool holders type GH305/GB305 size 04 see from page 122

Tool material	Solid carbide		
Type	GE 305	GE 305	GE 305
Surface	F	C	○
	FIRE	TiCN	bright

Cutting data page 149

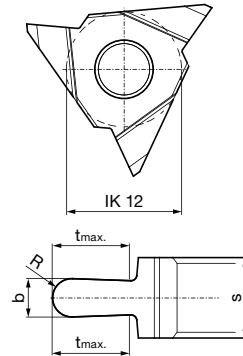

System 305

Series no. **25613** **25614** **25615**

Code no.	Description	b ± 0.02	R	t max	s	Size
		mm	mm	mm	mm	
12.001	GE305.0050.025.AA.04.N	0.50	0.25	1.50	4.20	04
12.002	GE305.0100.050.AA.04.N	1.00	0.50	3.00	4.20	04
12.003	GE305.0110.055.AA.04.N	1.10	0.55	3.00	4.20	04
12.004	GE305.0120.060.AA.04.N	1.20	0.60	3.00	4.20	04
12.005	GE305.0140.070.AA.04.N	1.40	0.70	3.00	4.20	04
12.006	GE305.0150.075.AA.04.N	1.50	0.75	3.00	4.20	04
12.007	GE305.0160.080.AA.04.N	1.60	0.80	4.00	4.20	04
12.008	GE305.0180.090.AA.04.N	1.80	0.90	4.00	4.20	04
12.009	GE305.0200.100.AA.04.N	2.00	1.00	4.00	4.20	04
12.010	GE305.0220.110.AA.04.N	2.20	1.10	5.00	4.20	04
12.011	GE305.0250.125.AA.04.N	2.50	1.25	5.00	4.20	04
12.012	GE305.0280.140.AA.04.N	2.80	1.40	5.00	4.20	04
12.013	GE305.0300.150.AA.04.N	3.00	1.50	5.00	4.20	04
12.014	GE305.0360.180.AA.04.N	3.60	1.80	5.00	4.20	04
12.015	GE305.0400.200.AA.04.N	4.00	2.00	5.00	4.20	04



Indexable insert for axial grooving, straight slots

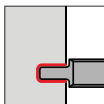

- grooving depth up to 3 mm
- right index. inserts in rh, left index. inserts in lh tool holders
- Geometry .BA ground

for tool holders type GH305 size 04 see from page 122

Tool material	Solid carbide		
Type	GA 305	GA 305	GA 305
Surface	F	C	○
	FIRE	TiCN	bright

Cutting data page 149

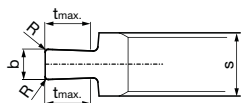
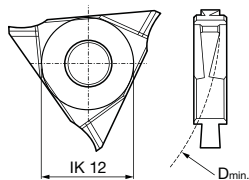

Right hand version shown
Left hand version mirror image

Series no.	25626	25628	25630
Cutting direction	(R)	(R)	(R)

Code no.	Description	D min	b ± 0.02	R	t max	s	Size
		mm	mm	mm	mm	mm	
12.001	GA305.0150.020.BA.04.R	15.00	1.50	0.20	2.00	4.20	04
12.002	GA305.0200.020.BA.04.R	30.00	2.00	0.20	3.00	4.20	04
12.003	GA305.0250.020.BA.04.R	30.00	2.50	0.20	3.00	4.20	04
12.004	GA305.0300.020.BA.04.R	30.00	3.00	0.20	3.00	4.20	04

Series no.	25627	25629	25631
Cutting direction	(L)	(L)	(L)

Code no.	Description	D min	b ± 0.02	R	t max	s	Size
		mm	mm	mm	mm	mm	
12.001	GA305.0150.020.BA.04.L	15.00	1.50	0.20	2.00	4.20	04
12.002	GA305.0200.020.BA.04.L	30.00	2.00	0.20	3.00	4.20	04
12.003	GA305.0250.020.BA.04.L	30.00	2.50	0.20	3.00	4.20	04
12.004	GA305.0300.020.BA.04.L	30.00	3.00	0.20	3.00	4.20	04



Indexable insert for axial grooving, full radius slots

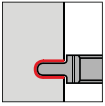

- grooving depth up to 3 mm
- right index. inserts in rh, left index. inserts in lh tool holders
- Geometry .AA ground

for tool holders type GH305 size 04 see from page 122

Tool material	Solid carbide		
Type	GA 305	GA 305	GA 305
Surface	F	C	○
	FIRE	TiCN	bright

Cutting data page 149

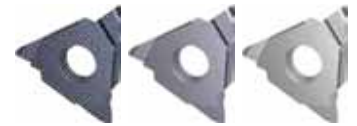
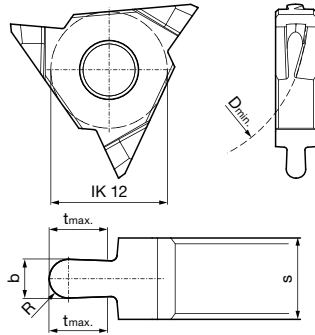

Right hand version shown
Left hand version mirror image

Series no.	25634	25636	25638
Cutting direction	(R)	(R)	(R)

Code no.	Description	D min	b ± 0.02	R	t max	s	Size
		mm	mm	mm	mm	mm	
12.001	GA305.0150.075.AA.04.R	15.00	1.50	0.75	2.00	4.20	04
12.002	GA305.0200.100.AA.04.R	30.00	2.00	1.00	3.00	4.20	04
12.003	GA305.0300.150.AA.04.R	30.00	3.00	1.50	3.00	4.20	04
12.004	GA305.0400.200.AA.04.R	30.00	4.00	2.00	3.00	4.20	04

Series no.	25635	25637	25639
Cutting direction	(L)	(L)	(L)

Code no.	Description	D min	b ± 0.02	R	t max	s	Size
		mm	mm	mm	mm	mm	
12.001	GA305.0150.075.AA.04.L	15.00	1.50	0.75	2.00	4.20	04
12.002	GA305.0200.100.AA.04.L	30.00	2.00	1.00	3.00	4.20	04
12.003	GA305.0300.150.AA.04.L	30.00	3.00	1.50	3.00	4.20	04
12.004	GA305.0400.200.AA.04.L	30.00	4.00	2.00	3.00	4.20	04

System 305



Indexable insert for grooving axial external recesses

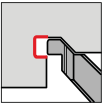

- grooving depth up to 2 mm
- right index. inserts in rh, left index. inserts in lh tool holders
- Geometry .AA ground
- for axial external recesses to ISO 9974-2

for tool holders type GH305, 45° depressed centre, see page 131

Tool material	Solid carbide		
Type	GA 305	GA 305	GA 305
Surface	F	C	○
	FIRE	TiCN	bright

Cutting data page 149

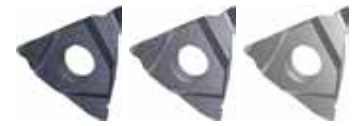
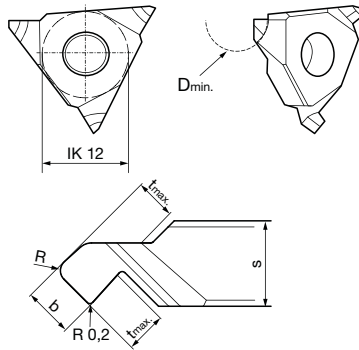

Right hand version shown
Left hand version mirror image

Series no.	25618	25620	25622
Cutting direction	(R)	(R)	(R)

Code no.	Description	D min	b ± 0.02	R	t max	s	Size
		mm	mm	mm	mm	mm	
12.001	GA305.0150.040.AA.04.R	8.00	1.50	0.40	1.60	4.20	04
12.002	GA305.0200.050.AA.04.R	12.00	2.00	0.50	1.90	4.20	04
12.003	GA305.0240.060.AA.04.R	20.00	2.40	0.60	2.00	4.20	04

Series no.	25619	25621	25623
Cutting direction	(L)	(L)	(L)

Code no.	Description	D min	b ± 0.02	R	t max	s	Size
		mm	mm	mm	mm	mm	
12.001	GA305.0150.040.AA.04.L	8.00	1.50	0.40	1.60	4.20	04
12.002	GA305.0200.050.AA.04.L	12.00	2.00	0.50	1.90	4.20	04
12.003	GA305.0240.060.AA.04.L	20.00	2.40	0.60	2.00	4.20	04

System 305



Indexable insert for thread turning, partial profile

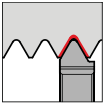

- grooving depth up to 3.5 mm
- ground top rake
- Geometry .AA ground

for tool holders type GH305 size 04 see from page 122

Tool material **Solid carbide**

Type	GG 305	GG 305	GG 305
Surface	F	C	○
	FIRE	TiCN	bright

Cutting data page 149

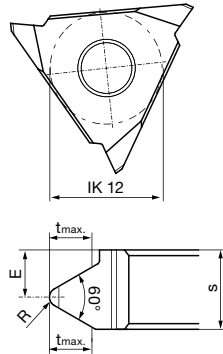

Right hand version shown
Left hand version mirror image

Series no. **25654** **25656** **25658**

Cutting direction **(R)** **(R)** **(R)**

Code no.	Description	P	E	R	t max	s	Size
			mm	mm	mm	mm	
12.010	GG305.TM00.100.AA.04.R	1.00	3.60	0.14	0.70	4.20	04
12.020	GG305.TM00.125.AA.04.R	1.25	3.50	0.17	0.85	4.20	04
12.030	GG305.TM00.150.AA.04.R	1.50	3.40	0.21	1.00	4.20	04
12.040	GG305.TM00.175.AA.04.R	1.75	3.20	0.25	1.20	4.20	04
12.050	GG305.TM00.200.AA.04.R	2.00	3.10	0.28	1.35	4.20	04
12.060	GG305.TM00.250.AA.04.R	2.50	2.90	0.36	1.65	4.20	04
12.070	GG305.TM00.300.AA.04.R	3.00	2.60	0.43	2.60	4.20	04
12.080	GG305.TM00.600.AA.06.R	3.0-6.0	3.50	0.43	3.50	6.20	06
12.090	GG305.TM00.350.AA.04.R	3.50	2.50	0.50	2.50	4.20	04

Series no. **25655** **25657** **25659**

Cutting direction **(L)** **(L)** **(L)**

Code no.	Description	P	E	R	t max	s	Size
			mm	mm	mm	mm	
12.010	GG305.TM00.100.AA.04.L	1.00	3.60	0.14	0.70	4.20	04
12.020	GG305.TM00.125.AA.04.L	1.25	3.50	0.17	0.85	4.20	04
12.030	GG305.TM00.150.AA.04.L	1.50	3.40	0.21	1.00	4.20	04
12.040	GG305.TM00.175.AA.04.L	1.75	3.20	0.25	1.20	4.20	04
12.050	GG305.TM00.200.AA.04.L	2.00	3.10	0.28	1.35	4.20	04
12.060	GG305.TM00.250.AA.04.L	2.50	2.90	0.36	1.65	4.20	04
12.070	GG305.TM00.300.AA.04.L	3.00	2.60	0.43	2.60	4.20	04
12.080	GG305.TM00.600.AA.06.L	3.0-6.0	3.50	0.43	3.50	6.20	06
12.090	GG305.TM00.350.AA.04.L	3.50	2.50	0.50	2.50	4.20	04

System 305



Indexable insert for thread turning, full profile

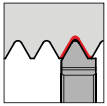

- grooving depth up to 3.9 mm
- ground top rake
- Geometry .AA ground

for tool holders type GH305 size 04 see from page 122

Cutting data page 149

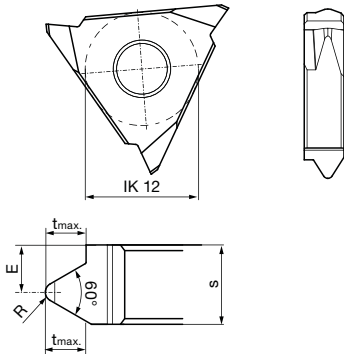

Right hand version shown
Left hand version mirror image



Series no.	25662	25664	25666
Cutting direction	(R)	(R)	(R)

Code no.	Description	P	E	R	t max	s	Size
		mm	mm	mm	mm	mm	
12.010	GG305.VM00.100.AA.04.R	1.00	3.60	0.14	0.70	4.20	04
12.020	GG305.VM00.125.AA.04.R	1.25	3.40	0.17	1.00	4.20	04
12.030	GG305.VM00.150.AA.04.R	1.50	3.30	0.21	1.15	4.20	04
12.040	GG305.VM00.175.AA.04.R	1.75	3.20	0.25	1.30	4.20	04
12.050	GG305.VM00.200.AA.04.R	2.00	3.10	0.28	1.45	4.20	04
12.060	GG305.VM00.250.AA.04.R	2.50	2.90	0.36	1.75	4.20	04
12.070	GG305.VM00.300.AA.04.R	3.00	2.70	0.43	2.10	4.20	04
12.080	GG305.VM00.350.AA.04.R	3.50	2.40	0.50	2.40	4.20	04
12.090	GG305.VM00.400.AA.06.R	4.00	4.20	0.57	2.70	6.20	06
12.100	GG305.VM00.500.AA.06.R	5.00	3.80	0.72	3.30	6.20	06
12.110	GG305.VM00.600.AA.08.R	6.00	5.20	0.86	3.90	8.20	08

Series no.	25663	25665	25667
Cutting direction	(L)	(L)	(L)

Code no.	Description	P	E	R	t max	s	Size
		mm	mm	mm	mm	mm	
12.010	GG305.VM00.100.AA.04.L	1.00	3.60	0.14	0.70	4.20	04
12.020	GG305.VM00.125.AA.04.L	1.25	3.40	0.17	1.00	4.20	04
12.030	GG305.VM00.150.AA.04.L	1.50	3.30	0.21	1.15	4.20	04
12.040	GG305.VM00.175.AA.04.L	1.75	3.20	0.25	1.30	4.20	04
12.050	GG305.VM00.200.AA.04.L	2.00	3.10	0.28	1.45	4.20	04
12.060	GG305.VM00.250.AA.04.L	2.50	2.90	0.36	1.75	4.20	04
12.070	GG305.VM00.300.AA.04.L	3.00	2.70	0.43	2.10	4.20	04
12.080	GG305.VM00.350.AA.04.L	3.50	2.40	0.50	2.40	4.20	04
12.090	GG305.VM00.400.AA.06.L	4.00	4.20	0.57	2.70	6.20	06
12.100	GG305.VM00.500.AA.06.L	5.00	3.80	0.72	3.30	6.20	06
12.110	GG305.VM00.600.AA.08.L	6.00	5.20	0.86	3.90	8.20	08



Indexable insert for parting off

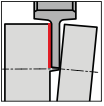

- grooving depth up to 5 mm
- Indexable insert applicable in right and left holders
- Geometry .AA ground
- without front cutting angle

for tool holders type GH305 size 04 see from page 122

Tool material	Solid carbide		
Type	GZ 305	GZ 305	GZ 305
Surface	F	C	○
	FIRE	TiCN	bright

Cutting data page 149

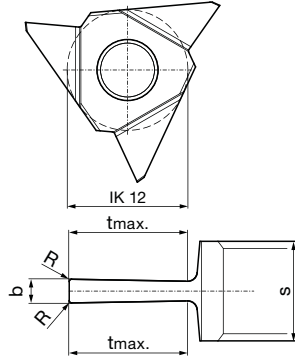

Series no. **25641** **25642** **25643**

Code no.	Description	b ± 0.02	R	t max	s	Size
		mm	mm	mm	mm	
12.001	GZ305.0100.000.AA.04.N	1.00	0.10	5.00	4.20	04
12.002	GZ305.0150.000.AA.04.N	1.50	0.10	5.00	4.20	04

System 305



Indexable insert for parting off

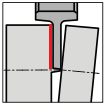

- **grooving depth up to 5 mm**
- Indexable insert applicable in right and left holders
- Geometry .AA ground
- with front cutting angle

for tool holders type GH305 size 04 see from page 122

Tool material	Solid carbide		
Type	GZ 305	GZ 305	GZ 305
Surface	F	C	○
	FIRE	TiCN	bright

Cutting data page 149

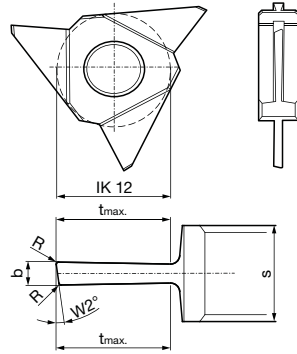

Right hand version shown
Left hand version mirror image

Series no. **25646** **25648** **25650**
version right-hand right-hand right-hand

Code no.	Description	b ± 0.02	R	W2	t max	s	Size
		mm	mm	°	mm	mm	
12.001	GZ305.0100.080.AA.04.R	1.00	0.10	8.00	5.00	4.20	04
12.002	GZ305.0150.080.AA.04.R	1.50	0.10	8.00	5.00	4.20	04

Series no. **25647** **25649** **25651**
version left-hand left-hand left-hand

Code no.	Description	b ± 0.02	R	W2	t max	s	Size
		mm	mm	°	mm	mm	
12.001	GZ305.0100.080.AA.04.L	1.00	0.10	8.00	5.00	4.20	04
12.002	GZ305.0150.080.AA.04.L	1.50	0.10	8.00	5.00	4.20	04

System 305



TECHNICAL SECTION & ACCESSORIES





Machining	Feed range f (IPR)	Point radius R (mm)	Cutting depth a _p (in)	General formulas
	0.0008 - 0.0031	R 0.05 (0.002in) R 0.10 (0.004in) R 0.15 (0.006in) R 0.20 (0.008in) R 0.25 (0.010in) R 0.30 (0.012in)	0.0008 - 0.0028 0.0020 - 0.0059 0.0031 - 0.0079 0.0047 - 0.0098 0.0051 - 0.0110 0.0067 - 0.0138	Cutting speed (SFM) RPM x Dia. / 3.82 = SFM
	0.0004 - 0.0012			Revolutions per minute (RPM) SFM x 3.82 / Dia. = RPM
	0.0004 - 0.0020		Rule of thumb: a _p ~ r	Feed rate (IPM) IPR x RPM = IPM

Guide values for feed and cutting depths

ISO	Material	Material examples/ material number	Tensile strength (N/mm ²)	Brinell hardness (HB)	Cutting speed SFM (surface feet / min)				
					TiN	TiAlN nanoA	Bright		
P	Carbon steel	C <= 0.15 %	11SMn30+C / 1.0715 C15 / 1.0401	500 600	150 180	65-525	165-655	50-295	
		C ≥ 0.15-0.45 %	S235JR (ST37-2) / 1.0037 Ck22 / 1.1151	400 600	120 180				
		C > 0.45 %	S355JO (St52-3) / 1.0553 C60 / 1.0601	600 900	180 270				
	Low-alloyed steel (alloy content ≤5%)	annealed	16MnCr5 / 1.7131 18CrNi8 / 1.5920	650 650	200 200	65-525	165-590	50-230	
			heat-treatable	25CrMoV4 / 1.7218 42CrMo4V / 1.7225	900 1100				270 320
		High-alloyed steel (alloy content >5%)	annealed	X37CrMoV5-1 / 1.2343 X153CrMoV12 / 1.2379	750 850	220 250	80-295	130-460	-
			heat-treatable	55NiCrMoV7 / 1.2714	1200	350	-	100-330	-
	Cast steel	un-alloyed, low-alloyed	GS52 / 1.0552	600	180	65-395	100-590	-	
		high-alloyed	GX40CrNiSi22-10 / 1.4826	750	220	-	100-295	-	
	M	Stainless steel	martensitic, ferritic, tempered	X14CrMoS17 / 1.4104 X4CrNiMo16-5-1 / 1.4418	800 1000	240 300	65-230	100-295	-
austenitic, Ni > 8%				X5CrNi18-10 / 1.4301 X2CrNiMo17-12-2 / 1.4404	650	200	65-300	100-360	-
austenitic, ferritic (Duplex)			X2CrNiMoCuN25-6-3 / 1.4507 X2CrNiMoN25-7-4 / 1.4410	850	250	-	100-330	-	
K			Grey cast iron	low tensile strength	EN-GJL-200 (GG20) / 0.6020		180	100-490	100-590
	high tensile strength	EN-GJL-400 (GG40) / 0.6040			260	100-395	100-490	100-230	
	Spheroidal graphite iron	low tensile strength	EN-GJS-400-15 (GGG40) / 0.7040		160	100-425	100-525	-	
		high tensile strength	EN-GJS-700-2 (GGG70) / 0.7070		260	100-360	100-460	-	
	Malleable cast iron	low tensile strength	EN-GJMW-350-4 (GTW35) / 0.8035		125	100-425	100-525	-	
		high tensile strength	EN-GJMB-550-4 (GTS55) / 0.8155		250	100-360	100-460	-	
N	Al-alloys	non-heat-treatable <12% Si	EN-AW-2017 (AlCuMg1) / 3.1325		60	100-1805	100-1805	100-820	
		heat-treatable <12% Si	EN-AW-6082 (AlMgSi1) / 3.2315		100	100-1310	100-1310	100-590	
	Al-cast-alloys	non-heat-treatable <12% Si	AlSi9Cu3 / 3.2163		80	100-1805	100-1805	100-820	
		heat-treatable <12% Si	AlSi10Mg / 3.2383		100	100-1310	100-1310	100-590	
	Copper alloys	brass, lead alloy	CuZn39Pb2 (MS58) / 2.0380	400	120	100-1310	100-1310	100-590	
		bronze	CuSn6 / 2.1020	500	150	100-240	100-240	100-590	
S	Heat resistant alloys, super alloys	NiFe-base, annealed	NiCr15Fe (Alloy600) / 2.4816	700		-	50-230		
		NiFe-base, hardened		950		-	50-165		
		NiCo-base, annealed	NiMo16Cr15W (Alloy C-276) / 2.4819	800		-	50-165		
		NiCo-base, cast		1100		-	30-130	-	
		NiCo-base, hardened	NiCr19NbMo (Alloy718) / 2.4668	1200		-	30-115		
	Titanium-alloys	annealed	Ti6Al4V / 3.7164	900		-	15-165		
		hardened		1200		-	30-115		
	H	Hardened steels	Heat-treatable steel			> 52 HRC	-	65-130	-
Heat-treatable/case hardened steel					> 59 HRC	-	30-100	-	
Heat-treatable/case hardened steel					> 62 HRC	-	(CBN)	-	

The specified values must be adapted to the machine and machining conditions.



SYSTEM 305

<p>Geometry .BA ground round chip breaker</p>	<p>Feed rate f (IPR)</p> <p>↓ 0.0012 - 0.0059</p> <p>↔ 0.0008 - 0.0047 ap = 0.0039 - 0.0197 in</p>	<p>Geometry .AA ground flat chip breaker</p>	<p>Feed rate f (IPR)</p> <p>↓ 0.0012 - 0.0059</p> <p>↔ 0.0008 - 0.0047 ap = 0.0039 - 0.0197 in</p>	<p>General formulas</p> <p>Cutting speed (SFM) RPM x Dia. / 3.82 = SFM</p> <p>Revolutions per minute (RPM) SFM x 3.82 / Dia. = RPM</p> <p>Feed rate (IPM) IPR x RPM = IPM</p>
	<p>↓ = radial feed direction ↔ = axial feed direction</p>			

ISO	Material		Material examples/ material number	Tensile strength (N/mm ²)	Brinell hardness (HB)	Cutting speed (surface feet / min)	
						FIREX/nanoFIREX Ⓡ	TiCN Ⓒ
P	Carbon steel	C <= 0.15 %	11SMn30+C / 1.0715 C15 / 1.0401	500 600	150 180	490-720	425-655
		C ≥ 0.15 - 0.45 %	S235JR (ST37-2) / 1.0037 Ck22 / 1.1151	400 600	120 180		
		C > 0.45 %	S355JO (St52-3) / 1.0553 C60 / 1.0601	600 900	180 270		
	Low-alloyed steel (alloy content ≤ 5%)	annealed	16MnCr5 / 1.7131 18CrNi8 / 1.5920	650 650	200 200	395-560	295-490
		heat-treatable	25CrMoV4 / 1.7218 42CrMo4V / 1.7225	900 1100	270 320		
	High-alloyed steel (alloy content > 5%)	annealed	X37CrMoV5-1 / 1.2343 X153CrMoV12 / 1.2379	750 850	220 250	425-590	-
		heat-treatable	55NiCrMoV7 / 1.2714	1200	350		
	Cast steel	un-alloyed, low-alloyed	GS52 / 1.0552	600	180	425-590	-
		high-alloyed	GX40CrNiSi22-10 / 1.4826	750	220	330-460	-
M	Stainless steel	martensitic, ferritic, tempered	X14CrMoS17 / 1.4104 X4CrNiMo16-5-1 / 1.4418	800 1000	240 300	295-525	230-460
			austenitic, Ni > 8%	X5CrNi18-10 / 1.4301 X2CrNiMo17-12-2 / 1.4404	650		
		austenitic, ferritic (Duplex)		X2CrNiMoCuN25-6-3 / 1.4507 X2CrNiMoN25-7-4 / 1.4410	850	250	230-330
			K	Grey cast iron	low tensile strength	EN-GJL-200 (GG20) / 0.6020	
high tensile strength	EN-GJL-400 (GG40) / 0.6040				260	230-360	-
Spheroidal graphite iron	low tensile strength	EN-GJS-400-15 (GGG40) / 0.7040			160	295-490	230-330
	high tensile strength	EN-GJS-700-2 (GGG70) / 0.7070			260	230-360	165-295
Malleable cast iron	low tensile strength	EN-GJMW-350-4 (GTW35) / 0.8035			125	230-460	165-330
	high tensile strength	EN-GJMB-550-4 (GTS55) / 0.8155			250	165-295	165-230
N	Al-alloys	non-heat-treatable <12% Si	EN-AW-2017 (AlCuMg1) / 3.1325		60	-	1640-2625
		heat-treatable <12% Si	EN-AW-6082 (AlMgSi1) / 3.2315		100	-	655-1310
	Al-cast-alloys	non-heat-treatable <12% Si	AlSi9Cu3 / 3.2163		80	-	1640-2625
		heat-treatable <12% Si	AlSi10Mg / 3.2383		100	-	655-1310
	Copper alloys	brass, lead alloy	CuZn39Pb2 (MS58) / 2.0380	400	120	-	435-820
		bronze	CuSn6 / 2.1020	500	150	-	330-590
S	Heat resistant alloys, super alloys	NiFe-base, annealed	NiCr15Fe (Alloy600) / 2.4816	700		-	100-230
		NiFe-base, hardened		950		-	400-165
		NiCo-base, annealed	NiMo16Cr15W (Alloy C-276) / 2.4819	800		-	100-195
		NiCo-base, cast		1100		-	100-130
		NiCo-base, hardened	NiCr19NbMo (Alloy718) / 2.4668	1200		-	65-100
	Titanium-alloys	annealed	Ti6Al4V / 3.7164	900		-	100-165
		hardened		1200		-	65-100
	H	Hardened steels	Heat-treatable steel			> 52 HRC	66-131
Heat-treatable/case hardened steel					> 59 HRC	33-98	-
Heat-treatable/case hardened steel					> 62 HRC	(CBN)	-

The specified values must be adapted to the machine and machining conditions.

General machining hints

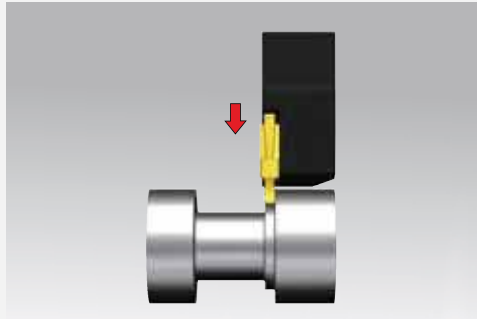

Width of machining should be min. 70% of the width of the cutting edge

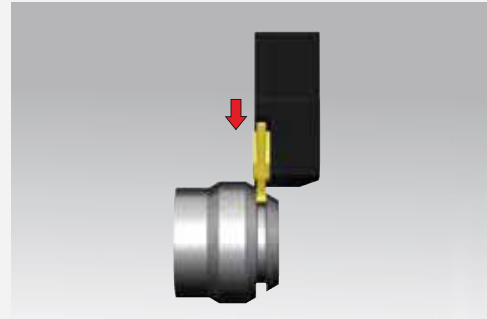

Reduce feed by 20 – 50% when grooving on angled faces

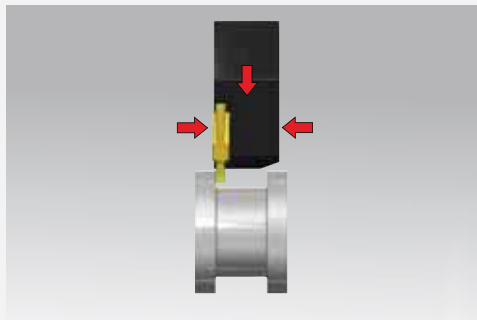

Recessing
 - radial in-feed
 - turning in axial direction
 - leave axial and radial stock for finishing

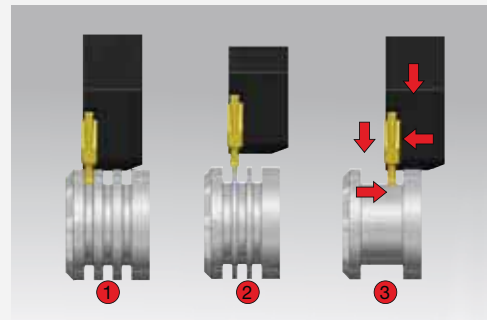

Process tip for recessing:
 1 – pre-grooving “comb”
 2 – removing remaining webs
 max width of webs: insert width $b - (2xr)$
 3 - finishing

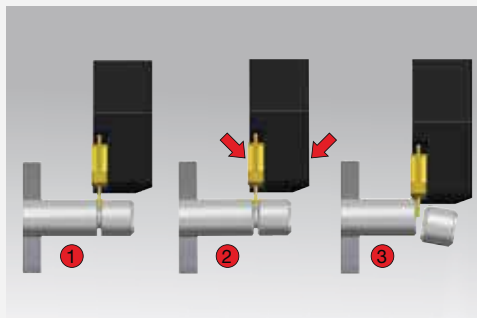

Process tip for parting:
 1 – pre-grooving
 2 – chamfering
 3 - parting

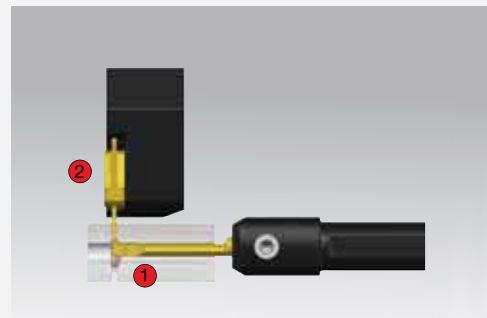







Process tip for parting into a central bore:
 1 – pre-grooving with tool type GV104
 2 – parting with tool type GZ305



Troubleshooting

Subject		Solution											
		Feed	Feed at centre	Cutting speed	RH/LH edge orientation	Corner radius	Wiper	Width of groove	Tool clamping	Workpiece clamping	Tool overhang	Centre height of cutting edge	Coolant
Related to wear	Edge chipping	↓	↓			↑			🔍	🔍	🔍	🔍	
	Build up edge			↑									👍
	Flank wear	🔍	↓	↓		↑						🔍	👍
	Plastic deformation	↓	↑	↓		↑							👍
Related to the component	Vibrations	↑		↓		↓		↓	🔍	🔍	↓	🔍	
	Burrs		↓		👍	↓						🔍	👍
	Surface	↓	↓	↑		↑	👍	↑	🔍	🔍	↓	🔍	👍
	Long chips (no chip breakage)	↑		↑									👍
	(too) short chips, compressed chips	↓											

-  decrease values (large impact)
-  increase values (large impact)
-  decrease values (low impact)
-  increase values (low impact)
-  check
-  apply



Application hints for the cutting insert GJ104/106 with wiper geometry

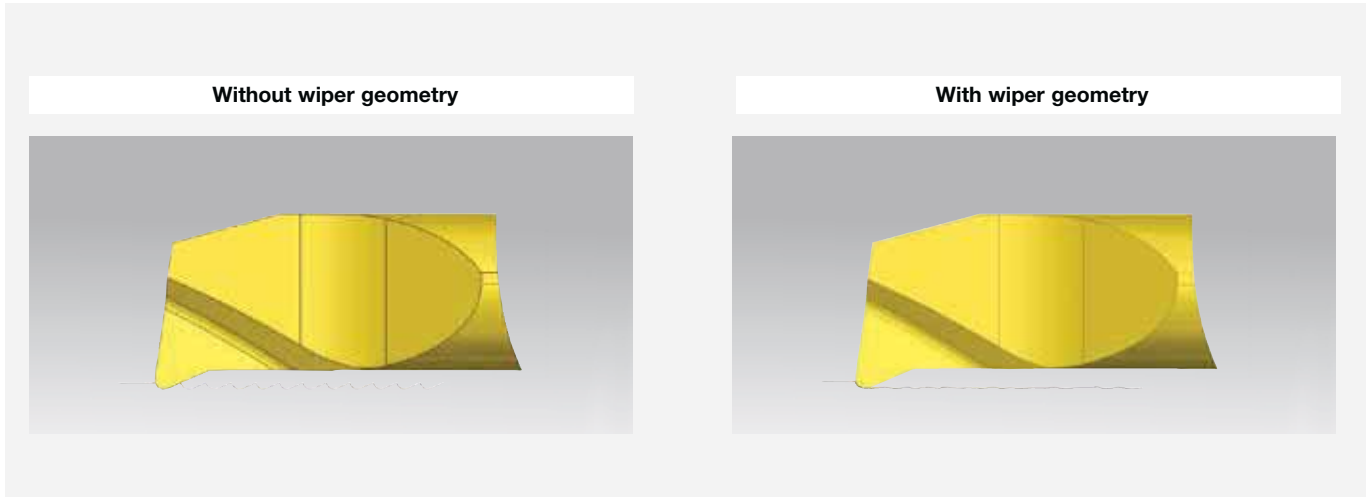

The wiper geometry offers multiple options

- You retain the feed rate of the cutting insert without wiper geometry and achieve a considerably better surface finish.
- You increase the feed rate taking the entire process (material, chip formation, stability) into consideration and achieve the following improvements:
 - reduced machining time
 - therefore reduced engagement of the tool, improving tool life
 - improved chip formation/chip breakage
 - thicker chip enables better heat dissipation

Please note the following carefully!

The cutting insert/holder must be positioned axially parallel to optimize the wiper. This is the only way the wiper geometry can achieve its desired effect to improve the surface finish.

General formulas to determine the surface finish quality

$R_{th} = f^2 / 8 \cdot r$	$r = f^2 / 8 \cdot R_{th}$	$f = \sqrt{8 \cdot r \cdot R_{th}}$
----------------------------	----------------------------	-------------------------------------

Application example

Application: Boring out Ø 4 mm		Tool selection		Customer benefit
Component:	Sleeve	System:	104	Rz 5-8 µm was achieved with a cutting insert without wiper. With a wiper cutting insert Rz values could be improved to 2-4 µm. In the 2nd step vc was increased to 130 m/min. This resulted in an improved surface finish.
Material:	42CrMo4	Holder:	GB104.0016.075.00.15.N.IK	
	1.7225	Insert:	GJ104.2337.020.17.40.R	
Machine:	Spinner		TiAlN nanoA	
Cooling:	20 bar			
Operat. step:	Finishing			
vc:	90 m/min			
f:	0.08 mm			
ap:	0.15			
Groov. depth:	-			



System 104/106

Positioning and clamping

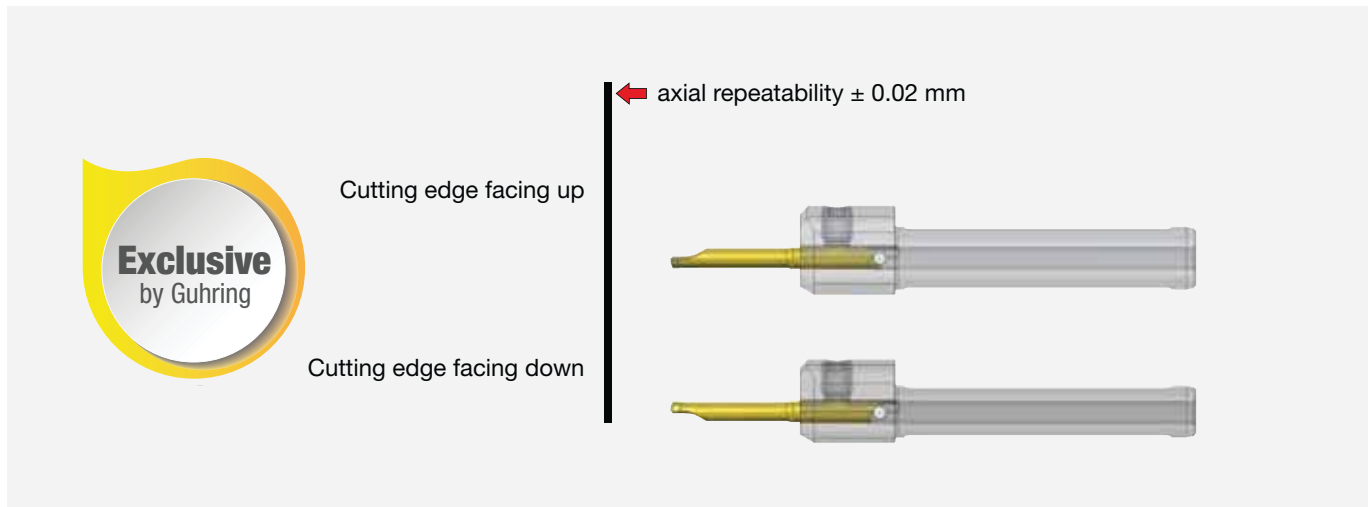

Guhring's system 104/106 is unique in terms of insert positioning and clamping: The position between cutting edge facing up and cutting edge facing down can be changed by keeping the same length position without loosening the holder.

Definition of the cutting edge position

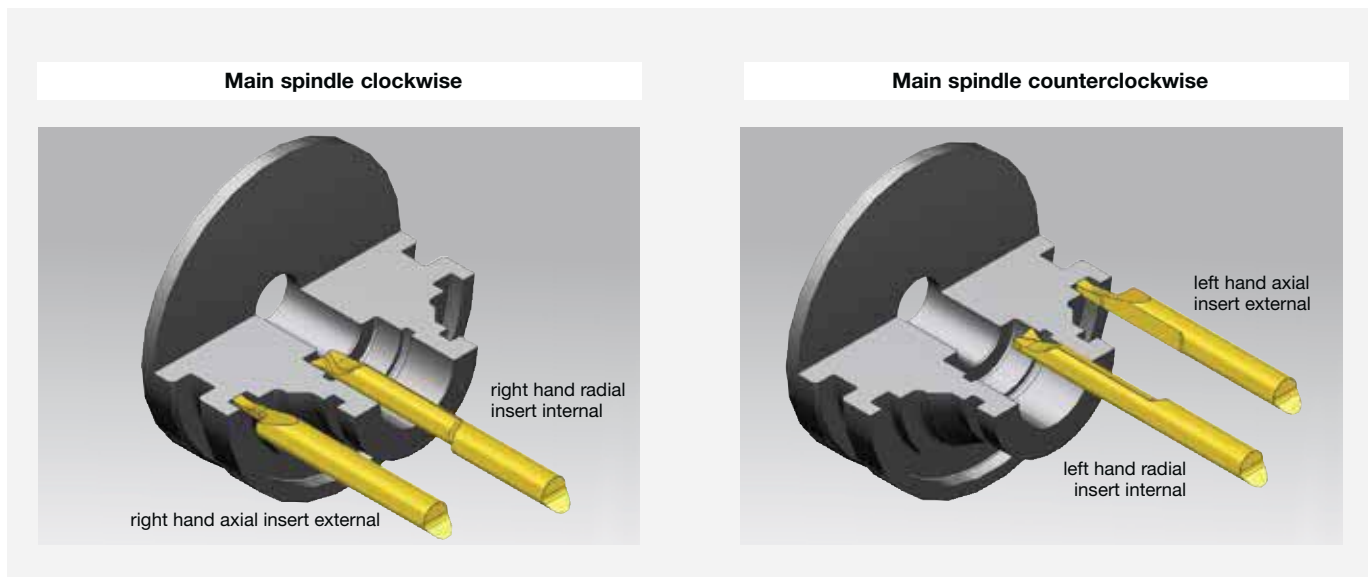



Internal threading System GG 104 and GG 106

Pitch/P		Recommended number of cuts with internal threading						
		Steel materials (tensile strength in N/mm ²)			Stainless steel	Cast iron	Heat-resistant alloys	Aluminium
mm	Gg/“	400-700	700-1150	> 1150				
0.3		3	4	5	5	3	5	3
0.5	48	5	6	8	8	5	8	5
0.8	32	7	8	9	9	7	9	7
1	24	8	9	10	10	8	10	8
1.25	20	10	11	12	12	10	12	10
1.5	16	12	13	15	15	12	15	12
1.75	14	14	15	18	18	14	18	14
2	12	16	17	20	20	16	20	16
3	8	22	24	30	30	22	30	22

Feed direction internal threading

Right-hand thread

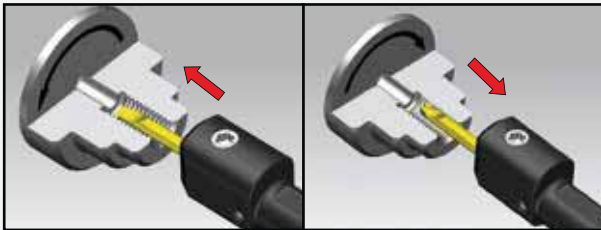

Insert: Right-hand design
Direction of rotation: Clockwise
M3 turning from outside in

Insert: Left-hand design
Direction of rotation: Counter-clockwise
M4 turning from inside out

Left-hand thread

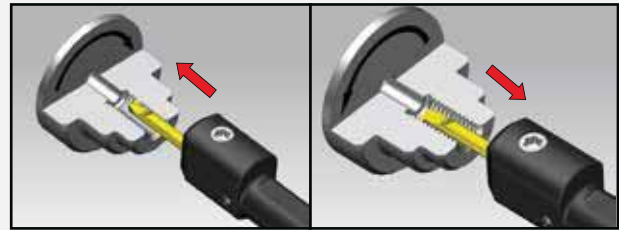

Insert: Left-hand design
Direction of rotation: Counterclockwise
M4 turning from outside in

Insert: Right-hand design
Direction of rotation: Clockwise
M3 turning from inside out

Feed process

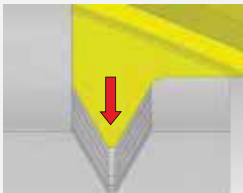

Radial feed

- Both cutting edges engaged at the same time
- High cutting pressure and thermal load
- Especially suitable for the machining of short-chipping materials
- For the production of threads with a small pitch and small thread depth as well as multiple start depths to prevent pitch errors

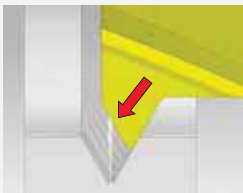

One-sided flank in-feed

- Only one cutting edge engaged
- Lower cutting pressure and thermal load
- Especially suitable for the machining of long-chipping materials
- Achieve a higher surface finish quality at the respective thread flank



Reciprocal flank in-feed

- Both cutting edges alternately engaged
- Lower cutting pressure and thermal load
- Especially suitable for the machining of long-chipping materials
- Achieve a higher surface finish quality at the flanks



Internal threading

System GG 104 and GG 106

Pre-drill diameters for metric threads						
Standard pitch thread				Fine pitch thread		
Nominal Ø	Pitch mm	Pre-drill Ø* full profile mm	Pre-drill Ø partial profile mm	Nominal Ø	Pitch mm	Pre-drill Ø partial profile mm
M 2	0.40	1.50	1.60	M 2	0.20	1.80
M 2.5	0.45	1.85	2.05	M 2.5	0.35	2.15
M 3	0.50	2.40	2.50	M 3	0.35	2.65
M 4	0.7	3.10	3.30	M 3.5	0.35	3.15
M 4.5	0.75		3.75	M 4	0.50	3.50
M 5	0.80	4.00	4.20	M 4.5	0.50	4.00
M 6	1.00		5.00	M 5	0.50	4.50
M 8	1.25		6.80	M 5.5	0.50	5.00
M 10	1.5		8.5	M 6	0.75	5.25
M 12	1.75		10.25			

*max. allowance (ap) in core diameter = 0.2 mm

Application example

Application: Internal thread		Tool selection		Customer benefit
Component:	Threaded sleeve	System:	106	Gühring's cutting insert leads to considerably less manual re-working. The customer saves time and money.
Material:	TiAl 6 V 4	Holder:	GB106.0016.090.00.22.N.IK	
	3.7165	Insert:	GG106.TM08.125.22.68.R	
Machine:	Mazak Nexus 200			
Cooling:	12 bar			
Operat.step:	Threading			
vc:	25 m/min			
f:	Pitch			
ap:				
Groov. depth:				

Broaching System GN 104 and GN 106

General hints

Please align the tool accurately.

The alignment surface on the tool holder GB104/106 provides a significant benefit.

Application instructions

- For blind holes there must be an undercut or cross hole at the bottom of the broach profile to allow chip evacuation.
- As a general rule the delivery of coolant (soluble or neat oil) helps the broaching process. It promotes chip evacuation, increases tool life, and improves surface finish.
- On the return stroke the tool must travel completely out of the hole.
- Pay attention to the feed \varnothing when programming the first stroke (load on the cutting corners).

Calculating the feed diameter $\varnothing d1$ for the first stroke

Example: Hole \varnothing : 8 mm
Groove width: 5 mm
Safety distance between cutting corners and workpiece \varnothing : 0.15 mm

r = radius workpiece (hole \varnothing 8/2) = 4
 b = Cutting edge / 2 (5/2) = 2.5

Feed radius = $\sqrt{r^2 - b^2}$ - safety distance

Feed radius = $\sqrt{4^2 - 2.5^2}$ - 0.15 = 2.97

Feed diameter $\varnothing d1 = 2.97 \times 2 = \varnothing 5.94$

The feed diameter for the first stroke in the machining example above is $\varnothing 5.94$

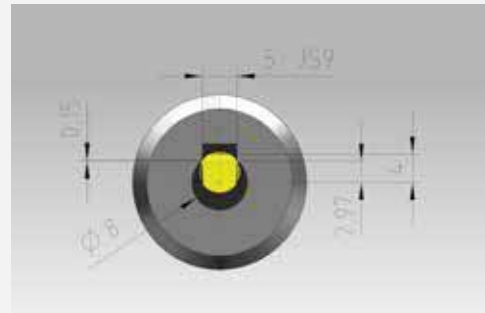

Feed and feed rate

- The feed per stroke is dependent on the tensile strength of the material to be machined.
- The feed rate when broaching corresponds to the cutting speed and is controlled by the Z-axis of the machine.
- Achievable speeds are partly limited by the machine conditions.

	Tensile strength (N/mm ²)					
	300	400	600	800	1000	1200
Feed rate (mm/min)	10000	8000	7000	6000	5000	4000
Feed per stroke (mm)	0.1	0.08	0.07	0.06	0.05	0.04

* Values are for guidance only. The machine condition, rigidity of component clamping as well as the workpiece material influence the cutting parameters.



Broaching System GN 104 and GN 106

Sequence of machining

Broaching square profile:

- The broaching inserts generate a 90° corner
- The component must be repositioned 4 times each 90° to complete the square profile

Broaching hexagon profile:

- The broaching inserts generate a 60° corner
- The component must be repositioned 6 times each 60° to complete the hexagon profile

Broaching Torx profile:

- The broaching inserts generate one section of the torx profile
- The component must be repositioned 6 times each 60° to complete the torx profile



Application example

Application: Hexagon broaching		Tool selection		Customer benefit
Component:	Sleeve	System:	106 Special tool	The current process required a high amount of manual rework. Also the tool life was low. With the Guhring tool the customer achieves a very good surface with high tool life. Also there is no more manual rework required.
Material:	X 10 CrNiS 18 9	Holder:	GB106.0025.075.00.22.S.IK	
	1.4305	Insert:	Special insert	
Machine:	Spinner TC 65		TiAlN nanoA	
Cooling:	20 bar			
Operat. step:	Semifinishing & fnishing			
vc:	-			
f:	3200 mm			
ap:	0,06			
Groov. depth:	SW 9.3 (special)			

Application hints for holder GH305...EST with adjustable coolant supply



The adjustable valve directs the coolant to the cutting edge as follows:



Coolant supply directed to the rake face

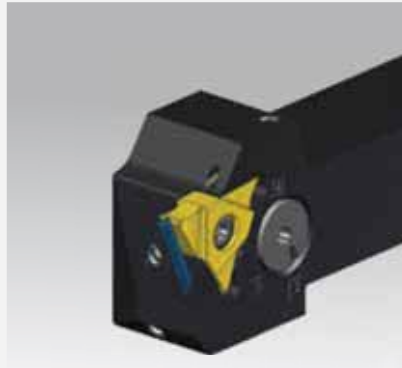

Coolant supply directed to the clearance face

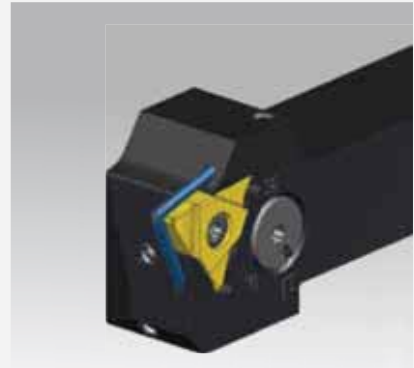

Coolant supply directed to both spots

The GH305 . . . EST is Gühring's patent pending grooving holder with internal coolant.

What makes it worth the effort?

- You can optimally provide your process with coolant even at low coolant pressure:
 - first choice is the coolant supply to the rake face
 - if chips interfere or prevent coolant delivery, the temperature can be effectively controlled by cooling the clearance face.
- With high coolant pressure we recommend cooling from both coolant holes:
 - cooling the rake face can positively influence chip fracture
 - cooling the clearance face provides additional temperature reduction of cutting edge

Application example

Application: External grooving radial		Tool selection		Customer benefit Gühring's precision ground insert offers more tool life than the just sintered product of the competitor. Additionally the customer reported better chip formation as well as improved surface quality.
Component:	Piston	System:	305	
Material:	17 CrNiM0 6	Holder:	GH305.2020.125.00.04.R.IK.EST	
	1.6587	Insert:	GE305.0200.020.BA.04.N	
Machine:	Mazak Quick Turn Smart 200			
Cooling:	20 bar			
Operat. step:	groov. 58 HRC, 0.8mm case d.			
vc:	40 m/min			
f:	0.06 mm			
ap:				
Groov. depth:	3 mm			

Micro-precision drills from Guhring

Small Diameter Drill Offering

- *High speed cobalt from 0.05 mm \varnothing*
- *Coolant fed carbide from 0.5 mm \varnothing*
- *Solid carbide from 0.1 mm \varnothing*
- *Fractional sizes, wire sizes*

featuring

EXCLUSIVELINE[®]

*Micro precision carbide drills
4xD and 7xD, non-coolant fed,
AlTiN coating
5xD, 8xD, and 12xD, coolant fed,
TiAlN coating*





Torque wrenches



Series no. **4915**

Size	Torque Nm	l1 mm	Code no.
1/4" hex	2-8	200	8.000



Torx-Plus interchangeable blade

Series no. **4960**

Size	Torque Nm	l1 mm	Code no.
1/4" hex, 15 IP	6.6 Nm	175	15.000

Key with T-handle code no. 15.000
Allen key code no. 15.001



Torx-Plus screwdriver

Series no. **25904**

Size	l1 mm	Code no.
15IP	65	15.000
15IP	97	15.001

Clamping screws



For Systems 104 & 106

Series no. **25900**

Size	d1	l1 mm	Code no.
15IP	M6	7.5	6.000



For System 305

Series no. **25901**

Size	d1	l1 mm	Code no.
15IP	M4	15	4.000
15IP	M4	22	4.001



Series no. **25902**

Size	d1	l1 mm	Code no.
15IP	M4	15	4.000
15IP	M4	7	4.001

Activation screws



Series no. **25905**

Size	d1	l1 mm	Code no.
SW 4	G1/8	5	5.000

SPECIAL SOLUTIONS made to measure

SYSTEM 104



**Face grooving and copying
dovetail grooving**

Insert: GA 104



Internal threading

Insert: GG 104

SYSTEM 106



**Copying a radius at the bottom
of a bore on a turning center**

Insert: GT 106



**Broaching an internal spline,
rough and finish cutter in one tool**

Insert: GN 106

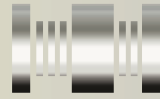

SYSTEM 305



**Broaching an internal longitudinal
grooves from hole \varnothing 30 mm,**

i.e. for profile forms or tooth profiles

Clamping holder and indexable insert type 305



**External/internal circular milling
of form recesses**

Milling body and indexable insert type 305



Indexable insert type 305, basic width 4.2 mm

Grooving with external edge chamfering,
form width up to 4.2 mm, form depth up to 4 mm

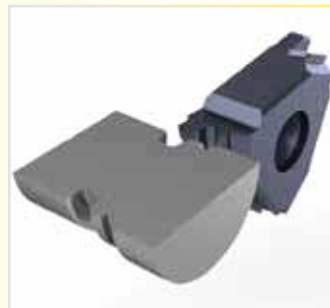

Indexable insert type 305, basic width 6.2 mm

Two grooves in one operation,
form width up to 6.2 mm, form depth up to 4 mm



Indexable insert type 305, basic width 8.2 mm

Profile form insert, external contour,
form width up to 8.2 mm, form depth up to 4 mm



Indexable insert type 305, basic width 12.2 mm

Profile form insert, external contour,
form width up to 12.2 mm, form depth up to 4 mm

SYSTEM HOLDERS & MODULAR TOOLS

Manufactured for you - quickly and cost-effectively

- Suitable for all inserts type 104, type 106 and indexable inserts type 305
- System holders can be supplied with polygon HSK-T or TS interface



System holder HSK-T
DIN ISO 12164-4

System holder with polygon
shank ISO 26623-1

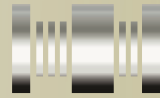

GROOVING SYSTEMS
BY **GUHRING**



System holder
TS ISO 26622-1

System holder with polygon
shank ISO 26623-1

Series	Description	Page
25226	Cutting insert for axial chamfering bores	50
25227	Cutting insert for axial chamfering bores	50
25228	Cutting insert for internal hexagon	57
25229	Cutting insert for internal hexagon	57
25231	Cutting insert for internal hexagon	57
25232	Cutting insert for internal square	58
25233	Cutting insert for internal square	58
25235	Cutting insert for internal square	58
25236	Cutting insert for Torx	59
25237	Cutting insert for Torx	59
25239	Cutting insert for Torx	59
25300	Round shank holder, clamping screw top	62
25301	Round shank holder, clamping screw lateral	63
25302	Round shank holder, 4 clamping surfaces	118
25304	Square shank holder, 90° offset	70
25305	Square shank holder, 90° offset	70
25307	Polygon shank holder, to ISO 26623, straight 0°	71
25308	Polygon shank holder, to ISO 26623, off-set 90°	72
25309	Polygon shank holder, to ISO 26623, off-set 90°	72
25311	HSK-T holder, to ISO 12164-3, straight 0°	73
25314	Square shank holder, straight 0°	69
25315	Square shank holder, straight 0°	69
25316	Round shank holder, clamping screw above, for Citizen machine	66
25317	Round shank holder, clamping screw above, for Star machine	67
25318	Round shank holder, clamping screw above, for Tornos machine	68
25319	Round shank holder, clamping screw above, without clamping surfaces	65
25320	Round shank holder, clamping screw above, four clamping surfaces	64
25350	Square shank holder straight, external machining, without IC	122
25351	Square shank holder straight, external machining, without IC	123
25352	Square shank holder straight, external machining, with IC	124
25353	Square shank holder straight, external machining, with IC	125
25356	Square shank holder 90° offset, external machining, without IC	127
25357	Square shank holder 90° offset, external machining, without IC	128
25358	Square shank holder 90° offset, external machining, with IC	129
25359	Square shank holder 90° offset, external machining, with IC	130
25362	Square shank holder 45° offset, external machining, without IC	131
25363	Square shank holder 45° offset, external machining, without IC	131
25364	Square shank holder 45° offset, external machining, with IC	132
25365	Square shank holder 45° offset, external machining, with IC	132
25368	Round shank holder, internal machining, without IC	133
25369	Round shank holder, internal machining, without IC	133
25370	Round shank holder, internal machining, with IC	135
25371	Round shank holder, internal machining, with IC	136
25372	Square shank holder straight, external machining, IC adjustable	126
25373	Square shank holder straight, external machining, IC adjustable	126
25500	Cutting insert for boring out and profiling	80
25501	Cutting insert for boring out and profiling	81
25502	Cutting insert for boring out and profiling	80
25503	Cutting insert for boring out and profiling	81
25506	Cutting insert for boring out and profiling	80
25507	Cutting insert for boring out and profiling	81
25508	Cutting insert for boring out and profiling	98
25509	Cutting insert for boring out and profiling	99
25510	Cutting insert for boring out and profiling	98
25511	Cutting insert for boring out and profiling	99
25514	Cutting insert for boring out and profiling	98
25515	Cutting insert for boring out and profiling	99
25516	Cutting insert for boring out and profiling	100
25517	Cutting insert for boring out and profiling	101
25518	Cutting insert for boring out and profiling	100
25519	Cutting insert for boring out and profiling	101
25522	Cutting insert for boring out and profiling	100
25523	Cutting insert for boring out and profiling	101
25601	Indexable insert for radial grooving external and internal	137
25602	Indexable insert for radial grooving external and internal	137
25603	Indexable insert for radial grooving external and internal	137
25605	Indexable insert for radial grooving and copying external and internal	138
25606	Indexable insert for radial grooving and copying external and internal	138
25607	Indexable insert for radial grooving and copying external and internal	138
25613	Indexable insert for radial grooving and copying external and internal	139

Series	Description	Page
25614	Indexable insert for radial grooving and copying external and internal	139
25615	Indexable insert for radial grooving and copying external and internal	139
25618	Indexable insert for grooving axial external recesses	142
25619	Indexable insert for grooving axial external recesses	142
25620	Indexable insert for grooving axial external recesses	142
25621	Indexable insert for grooving axial external recesses	142
25622	Indexable insert for grooving axial external recesses	142
25623	Indexable insert for grooving axial external recesses	142
25626	Indexable insert for axial grooving, straight slots	140
25627	Indexable insert for axial grooving, straight slots	140
25628	Indexable insert for axial grooving, straight slots	140
25629	Indexable insert for axial grooving, straight slots	140
25630	Indexable insert for axial grooving, straight slots	140
25631	Indexable insert for axial grooving, straight slots	140
25634	Indexable insert for axial grooving, full radius slots	141
25635	Indexable insert for axial grooving, full radius slots	141
25636	Indexable insert for axial grooving, full radius slots	141
25637	Indexable insert for axial grooving, full radius slots	141
25638	Indexable insert for axial grooving, full radius slots	141
25639	Indexable insert for axial grooving, full radius slots	141
25641	Indexable insert for parting off	145
25642	Indexable insert for parting off	145
25643	Indexable insert for parting off	145
25646	Indexable insert for parting off	146
25647	Indexable insert for parting off	146
25648	Indexable insert for parting off	146
25649	Indexable insert for parting off	146
25650	Indexable insert for parting off	146
25651	Indexable insert for parting off	146
25654	Indexable insert for thread turning, part profile	143
25655	Indexable insert for thread turning, part profile	143
25656	Indexable insert for thread turning, part profile	143
25657	Indexable insert for thread turning, part profile	143
25658	Indexable insert for thread turning, part profile	143
25659	Indexable insert for thread turning, part profile	143
25662	Indexable insert for thread turning, full profile	144
25663	Indexable insert for thread turning, full profile	144
25664	Indexable insert for thread turning, full profile	144
25665	Indexable insert for thread turning, full profile	144
25666	Indexable insert for thread turning, full profile	144
25667	Indexable insert for thread turning, full profile	144
25700	Cutting insert for boring out and profiling	91
25701	Cutting insert for boring out and profiling	93
25702	Cutting insert for boring out and profiling	91
25703	Cutting insert for boring out and profiling	93
25706	Cutting insert for boring out and profiling	91
25707	Cutting insert for boring out and profiling	93
25708	Cutting insert for boring out and profiling	94
25709	Cutting insert for boring out and profiling	95
25710	Cutting insert for boring out and profiling	94
25711	Cutting insert for boring out and profiling	95
25714	Cutting insert for boring out and profiling	94
25715	Cutting insert for boring out and profiling	95
25716	Cutting insert for boring out and profiling	96
25717	Cutting insert for boring out and profiling	97
25718	Cutting insert for boring out and profiling	96
25719	Cutting insert for boring out and profiling	97
25722	Cutting insert for boring out and profiling	96
25723	Cutting insert for boring out and profiling	97
25732	Cutting insert for back boring and profiling	102
25733	Cutting insert for back boring and profiling	102
25734	Cutting insert for back boring and profiling	102
25735	Cutting insert for back boring and profiling	102
25738	Cutting insert for back boring and profiling	102
25739	Cutting insert for back boring and profiling	102
25740	Cutting insert for boring out and chamfering	103
25741	Cutting insert for boring out and chamfering	104
25742	Cutting insert for boring out and chamfering	103
25743	Cutting insert for boring out and chamfering	104
25746	Cutting insert for boring out and chamfering	103

GUHRING



GROOVING SYSTEMS

Highest quality and flexibility
thanks to a vast product offering.
All from one supplier.



GROOVING SYSTEMS
BY **GUHRING**

Guhring, Inc. Main Office
1445 Commerce Avenue
Brookfield, WI 53045
Tel (262) 784-6730 (800) 776-6170
Fax (262) 784-9096

East Coast Reconditioning Facility
121 W Dudley Town Rd.
Bloomfield, CT 06002

West Coast Distribution Center and Reconditioning Facility
15581 Computer Ln
Huntington Beach, CA 92649

Michigan Manufacturing and Reconditioning Facility
24875 Trans-X Road
Novi, MI 48375

Guhring Corp. (Canada)
20 Steckle Place, Unit #14
Kitchener, ON N2E 2C3
Tel (519) 748-9664 (800) 463-5555
Fax (519) 748-2954