



# SUPERIOR

ABRASIVES

PRODUCT GUIDE & REFERENCE MANUAL | 26



# SUPERIOR

## ABRASIVES

PRODUCT GUIDE & REFERENCE MANUAL 26  
 Supersedes all previous literature  
 Reorder Number 70600

**SUPERIOR ABRASIVES, LLC**  
 1620 Fieldstone Way  
 Vandalia, OH 45377  
 Call: (800) 235-9123  
 Fax: (800) 841-3441  
[sales@superiorabrasives.com](mailto:sales@superiorabrasives.com)

► Performance Rating Reference Guide		
● Best	◐ Better	○ Good

► RPM Classification Reference Guide	
Max RPM	Optimal RPM
Maximum safe operating speed as determined by product or accessory tolerances and tooling limitations. Exceeding Max RPM may cause property damage or personal injury.	Suggested speed at which products perform best in optimal conditions. Several variables affect performance conditions, and Optimal RPM is only used as a suggestion.

► Tool Operation Reference Guide	
	Airfile Belt Sander
	Portable Belt Sander
	Benchstand Belt Sander
	Backstand/ Wide Belt Sander
	Right Angle Grinder
	Right Angle Die Grinder
	Straight Die Grinder
	Flex Shaft Grinder
	Orbital Sander
	Platen Disc Sander
	Bench Grinder
	Pedestal Grinder
	Drill Press
	Hand Operation

<b>Our Company</b>	New Products . . . . .	2
	About Us . . . . .	4
<b>SHUR-BRITE® Nonwoven Abrasives</b>	Nonwoven Abrasives . . . . .	11
	Surface Conditioning . . . . .	17
	Discs . . . . . Quick Change Discs . . . . .	20
	Hook & Loop Discs . . . . .	24
	Flap Discs . . . . .	30
	Stars . . . . . Mandrel Mounted Stars . . . . .	31
	Belts . . . . .	32
	Satin Finishing . . . . .	35
	Discs . . . . . Quick Change Discs . . . . .	38
	Arbor Mounted Discs . . . . .	40
	Wheels . . . . . Wheels for Angle Grinders . . . . .	41
	Mounted Wheels. . . . .	43
	Duplex Wheels . . . . .	44
	Disc Wheels . . . . .	46
	Goblet Wheels . . . . .	47
	Brushes . . . . . Mounted Flap Brushes . . . . .	48
	Unmounted Flap Brushes . . . . .	49
	Stars . . . . . Mandrel Mounted Stars . . . . .	50
	Hand Pads . . . . .	52
	Rolls . . . . .	53
	Convolute . . . . .	55
	Wheels . . . . .	58
	Unitized. . . . .	61
	Wheels . . . . . Shank Mounted Wheels. . . . .	64
	Arbor Mounted Wheels . . . . .	64
	Discs . . . . . Quick Change Discs . . . . .	65
	Depressed Center Discs . . . . .	67
	Stripping . . . . .	71
	Wheels . . . . . Arbor Mounted Wheels . . . . .	74
	Shank Mounted Wheels. . . . .	75
	Discs . . . . . Depressed Center Discs . . . . .	76
	Quick Change Discs . . . . .	77
<b>SHUR-KUT® Coated Abrasives</b>	Coated Abrasives . . . . .	79
	Discs . . . . . Quick Change Discs . . . . .	84
	PSA Discs . . . . .	92
	Flap Discs . . . . .	98
	Resin Fiber Discs . . . . .	104
	Belts . . . . .	108
	Flap Wheels. . . . . Wheels for Angle Grinders . . . . .	113
	Mounted Wheels. . . . .	113
	Unmounted Wheels. . . . .	117
	Bore Polishers . . . . .	118
	Cartridge Rolls. . . . . Straight Cartridge Rolls . . . . .	120
	Tapered Cartridge Rolls. . . . .	123
	Abrasive Caps . . . . .	126
	Cones . . . . . Chamfering Cones . . . . .	130
	Center Lap Cones . . . . .	131
	Spiral Bands . . . . .	132
	Cross & Square Pads . . . . .	135
	Shop Rolls . . . . .	136
	Sheets . . . . . Cloth Sheets. . . . .	138
	Paper Sheets. . . . .	139
<b>Part Number Index</b>	Index . . . . .	140
<b>Conditions of Sales</b>	Terms & Conditions . . . . .	148

# New Products

## CERAMIC PREMIUM QUICK CHANGE DISCS . . . . . 85

Combining premium and selective backings, coatings and grains, we offer a new, competitive solution to cut rate, heat generation and operator fatigue.



## CERAMIC ADVANTAGE QUICK CHANGE DISCS . . . . . 85

The finer crystalline structure of Ceramic Advantage grains enhances self-sharpening effects, resulting in consistent performance throughout life.



## ABRASIVE CAPS . . . . . 126

The seamless structure of abrasive caps is advantageous for consistency in mold & die repair or fine detail work, maintaining its shape throughout product use.



## RED STRIPPING WHEELS & DISCS . . . 74

Premium, heavy duty stripping material with aggressive removal rate, extended life and consistent performance throughout. Available in many forms.



**BLAC-KUT HIGH DENSITY ZIRCONIA FLAP DISCS . . . . . 99**

A cost efficient option to high density discs, Blac-Kut Flap Discs are manufactured with larger flaps, providing effective material removal with an extended product life.



**MOUNTED SEAMLESS SATIN WHEELS . . . . . 43**

The unique structure of Seamless Satin Wheels is for depolishing and matte finishing without harsh and visible transition lines, avoiding secondary steps.



**WHEELS FOR RIGHT ANGLE GRINDERS**

Several new products are available exclusively for right angle grinders, taking advantage of the availability, familiarity and ease of use of the tool. Larger areas can be handled with right angle grinders versus smaller tools, and multiple steps can be rendered without changing your operational setup.

**Seamless Satin Wheels . . . . . 42**



**Satin Wheels . . . . . 42**



**Duplex Wheels . . . . . 41**



**Flap Wheels . . . . . 113**



Our ambition is to separate ourselves from the common manufacturer. To institute integrity and honor during our relentless pursuit of new and profitable markets. To develop new and innovative products and processes based on our customers' needs. It is our intent to create an enjoyable working environment based solely on our uncompromising commitment to our boss, the customer.

Lynne Henson, *President*





For over 50 years, we have been manufacturing coated and nonwoven abrasive products used in metal fabrication, industrial manufacturing, and specialty equipment production. Our standard product offering tackles the day to day challenges of grinding, finishing, and polishing. For demanding applications such as those found in the Aerospace, Medical, and Power Generation fields, our team of experienced engineers will design an abrasive solution tailored to fit any job.

Since 2007, Superior Abrasives has been participating in Lean Manufacturing. Our relentless pursuit of continual process improvement has enabled us to reduce production costs and eliminate waste while maintaining high quality standards at each stage of the production cycle. This ensures overall product quality and measured repeatable performance for the customer.

**Our mission is to provide world-class quality coated and nonwoven abrasive products through a superior customer buying experience.**

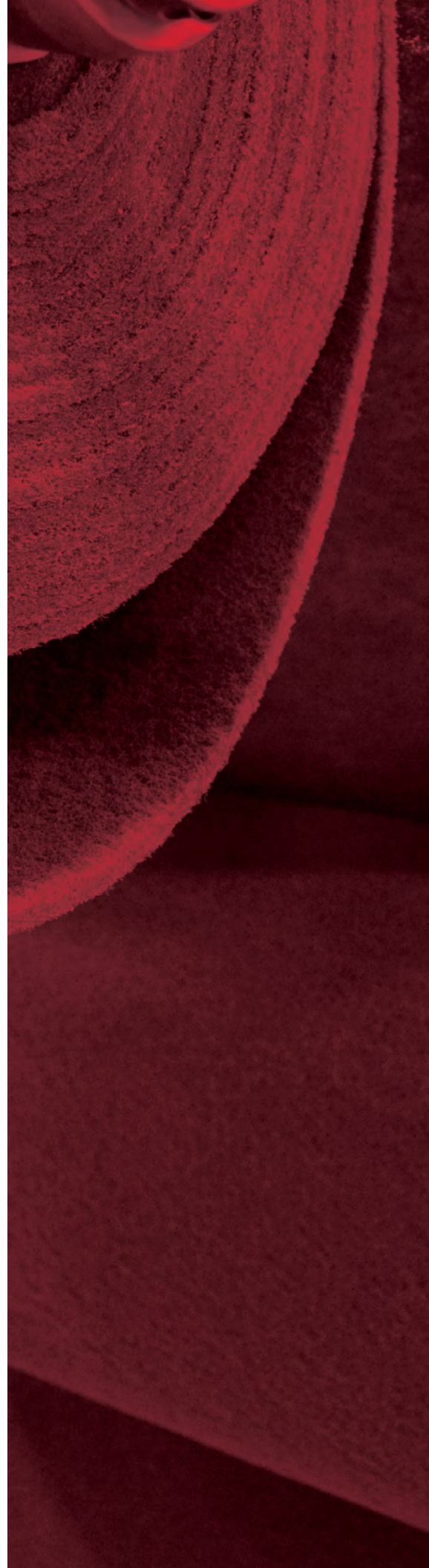



### Markets We Serve

- ▶ Aerospace
- ▶ Automotive & Truck
- ▶ Aviation
- ▶ Food Processing Equipment
- ▶ Machine Shops
- ▶ Medical
- ▶ Metal Fabrication
- ▶ Military Applications
- ▶ Mold & Pattern
- ▶ Pipeline
- ▶ Stainless Steel Finishing
- ▶ Tube Manufacturing



## Training & Conference Facility

Our modern facility features dedicated training resources for our employees and distributor partners. We are able to host large groups for classroom-like training sessions and share our product knowledge and industry application insight with you and your customers.

Please contact your Superior Representative to discuss and arrange an event tailored to your needs.



## Testing & Development Lab

Firsthand product or material testing and continual training are fundamental to the development of successful solutions. Outfitted with the latest operational and safety standards, our Testing & Development Lab hosts a variety of tooling and application resources. Based on customer discovery and requests, we are able to recreate product and application conditions to reduce response time and streamline sales cycles. To expand on our offering of product and application analysis, we can receive your actual components and workpieces to discover, test and share new and time-saving methods.

**We believe in sharing collective industry knowledge to instill confidence in both our employees and distributor partners. Opening communication channels and establishing partnerships allows us to offer the best services for your success.**





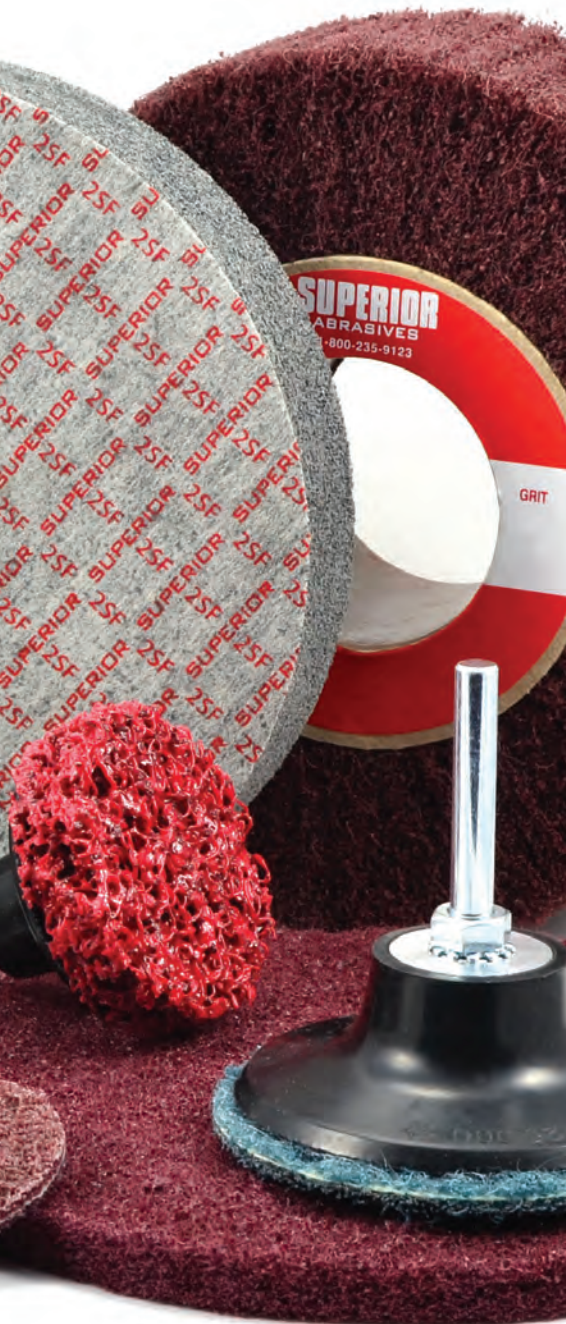

# SHUR-BRITE® Nonwoven Abrasives

# SHUR-BRITE®

## Nonwoven Features

SHUR-BRITE® offers the full range of nonwoven products for solving pre- or post-process applications. From shaping and deburring to cleaning and polishing, the versatile structure of SHUR-BRITE® Nonwoven Abrasives provides flexibility, conformability, strength and consistency. Complimentary to SHUR-KUT® Coated Abrasives, SHUR-BRITE® Nonwoven Abrasives are better able to navigate workpieces without marring or gouging and can enable any final finish requirements.



## Nonwoven Characteristics

All SHUR-BRITE® Nonwoven Abrasives consistently feature three components - nylon fibers, abrasive grains and resin. Each component is equally important and cannot perform a proper task without the others. The key to SHUR-BRITE® Nonwoven Abrasives are the nylon fibers, which give products their dimensional, open structure, and control the conformability.

The synthetic fiber structure, or fleece, is impregnated with abrasive grains and resins. The grains attach to the fiber, and the resin bonds these components together, leaving open areas throughout the nonwoven structure. Synthetic nylon fibers are the cushioning foundation which carry the grain media providing the cutting action.

▶ Components of Nonwoven Abrasives	
Nylon Fiber	<ul style="list-style-type: none"> <li>• Structural foundation of nonwoven abrasives</li> <li>• Synthetic, waterproof and chemical resistant</li> <li>• Controls loft and cushion of product</li> </ul>
Abrasive Grains	<ul style="list-style-type: none"> <li>• Responsible for cutting action, as with coated abrasives</li> <li>• Uniformly distributed throughout material</li> <li>• Aluminum Oxide (A/O) is more durable and lasts longer</li> <li>• Silicon Carbide (S/C) is sharper, resulting in a finer cut</li> </ul>
Resin	<ul style="list-style-type: none"> <li>• Strongly bonds all components together</li> <li>• Flexible adhesive</li> <li>• Waterproof and resistant to chemicals</li> <li>• Controls material density</li> </ul>

## Applications

- ▶ Directional finishing of stainless steel
- ▶ Mold & die restoration polishing
- ▶ Blending coated abrasive scratch patterns
- ▶ Surface preparation before painting or coating
- ▶ Architectural & aesthetic finishing
- ▶ Mirror finish polishing
- ▶ Blending parting lines on cast parts
- ▶ Edge breaking or corner radiusing
- ▶ Stock removal & weld blending
- ▶ Corrosion, rust & oxidation removal
- ▶ Cleaning & micro-deburring threads or gears
- ▶ Spatter removal & cleanup
- ▶ Removing flash & runners from cast parts
- ▶ Gasket & adhesives removal
- ▶ Paint, scale or surface coating removal
- ▶ Off-hand finishing & cleaning
- ▶ Cleaning & removing weld discoloration
- ▶ Blending & removing tool or handling blemishes



▶ Performance	Surface Conditioning	Satin Finishing	Convolute	Unitized	Stripping
Grinding	●				
Removal	●	○			●
Shaping	●		○	○	
Deburring	●	○	●	●	
Blending	●	●	●	●	○
Finishing	●	●	●	●	
Cleaning	○	●	●	●	●
Polishing	○	●	●	●	



SHUR-BRITE® Nonwoven Abrasives are each made with variable ratios of nylon fibers, abrasive grains and resins. These unique formulas control the performance and qualities of each product.

<b>Surface Conditioning</b> . . . . . 17	Fibers, grains and resins are supported by a woven substrate, or scrim reinforcement, adding lateral strength during high-speed mechanical use. Due to the scrim reinforcement, surface conditioning products are one-sided and used with attachments or intermediary tooling for more aggressive applications.
<b>Satin Finishing</b> . . . . . 35	Made without a scrim reinforcement, satin, or fleece, products are more pliable and omni-directional. Satin products remove less material and are well suited for general cleaning, blending and polishing applications.
<b>Convolute</b> . . . . . 55	Compressed nonwoven abrasives are wrapped convolutely around a center core, producing a harder, one-directional wheel. Resin ratios and winding tension determine wheel density. Used with stationary machines, due to the larger dimensions of the wheels.
<b>Unitized</b> . . . . . 61	Layered sheets of nonwoven abrasives are compressed in resins, forming a dense slab, from which smaller diameter wheels are produced. The density of unitized wheels allows controlled cutting, cleaning and polishing action for tighter tolerances.
<b>Stripping</b> . . . . . 71	Less compressed, yet harder and richer with resins, stripping products remove workpiece layers of the least resistance. The extremely open, less-conformable structure is ideal for fast removal of undesired coatings.







# SHUR-BRITE® Surface Conditioning

## Surface Conditioning Characteristics

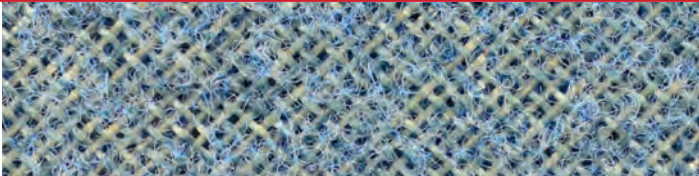
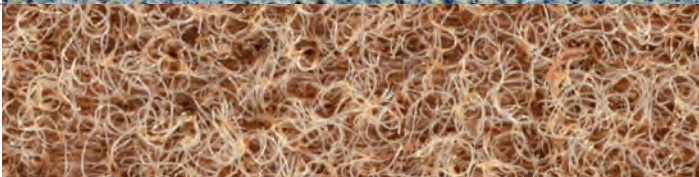
Like other nonwoven abrasives, SHUR-BRITE® Surface Conditioning consists of fibers, grains and resins, but is more aggressive. The unique characteristic is the integrated woven substrate, or scrim reinforcement, which creates strength and one-sided use, similar to SHUR-KUT® Coated Abrasives. Variations of SHUR-BRITE® Surface Conditioning reinforcement include Standard Scrim, Low Stretch (LS) and Flex (XF).

► Scrim Woven Reinforcements		
Standard Scrim	<ul style="list-style-type: none"> <li>• Open-weave reinforcement</li> <li>• Provides strength for mechanical use</li> <li>• For discs &amp; specialty products</li> </ul>	
LS (Low Stretch)	<ul style="list-style-type: none"> <li>• Tightly-woven reinforcement</li> <li>• Reduces stretching</li> <li>• Consistency in performance</li> <li>• For larger belts</li> </ul>	
XF (Flex)	<ul style="list-style-type: none"> <li>• Thin, pliable reinforcement</li> <li>• Flexible over contact wheels</li> <li>• Conforms to smaller areas</li> <li>• For file belts &amp; specialty products</li> </ul>	

## Surface Conditioning Features

Surface conditioning materials are considered the workhorse of SHUR-BRITE® Nonwoven Abrasives. Consider the same form and function of coated abrasives, with the added benefits of conformability and forgiveness, reduced loading, and consistent performance. SHUR-BRITE® Surface Conditioning products are not as aggressive as most SHUR-KUT® Coated Abrasives but showcase their versatility between heavy grinding and fine finishing with several material grades available.

- Consistent finishes throughout product life
- Lower operational heat than coated abrasives
- Reduced loading, smearing and discoloration
- Reduced process stages
- Suitable for wet or dry applications
- Conformable cutting action better for off-hand finesse

## Applications

- Mold & die restoration polishing
- Blending coated abrasive scratch patterns
- Surface preparation before painting or coating
- Architectural & aesthetic finishing
- Blending parting lines on cast parts
- Stock removal & weld blending
- Corrosion, rust & oxidation removal
- Spatter removal & cleanup
- Removing flash & runners from cast parts
- Gasket & adhesives removal
- Paint, scale or surface coating removal
- Off-hand finishing & cleaning

Within the SHUR-BRITE® Surface Conditioning offering, multiple performance factors can be met, depending on the applications.

Most Aggressive

<p style="font-size: 24px; margin: 0;">X<sup>E</sup></p> <p style="font-size: 18px; margin: 0;">High Performance</p>	<p style="font-size: 24px; margin: 0;">X<sup>E</sup></p> <p style="font-size: 18px; margin: 0;">High Performance</p>	<p>Heavy duty action with a unique resin formula. Firm cutting action for aggressive stock removal.</p>	
	<ul style="list-style-type: none"> <li>Extremely aggressive with long life</li> <li>Excellent performance on harder metals</li> </ul>		
	<p style="font-size: 24px; margin: 0;">E<sup>P</sup></p> <p style="font-size: 18px; margin: 0;">Extended Performance</p>	<p style="font-size: 24px; margin: 0;">E<sup>P</sup></p> <p style="font-size: 18px; margin: 0;">Extended Performance</p>	<p>Aggressive cutting action and consistent finishing. Better edge retention for extended life.</p>
		<ul style="list-style-type: none"> <li>Aggressive cut rate</li> <li>High edge endurance</li> </ul>	
<p style="font-size: 24px; margin: 0;">G<sup>D</sup></p> <p style="font-size: 18px; margin: 0;">Grind Duty</p>	<p style="font-size: 24px; margin: 0;">G<sup>D</sup></p> <p style="font-size: 18px; margin: 0;">Grind Duty</p>	<p>Balanced cutting rate and repeatable finishing qualities.</p>	
	<ul style="list-style-type: none"> <li>Aggressively blend welds and remove burrs</li> <li>Maintain a durable edge</li> </ul>		
<p style="font-size: 24px; margin: 0;">F<sup>D</sup></p> <p style="font-size: 18px; margin: 0;">Finish Duty</p>	<p style="font-size: 24px; margin: 0;">F<sup>D</sup></p> <p style="font-size: 18px; margin: 0;">Finish Duty</p>	<p>Excellent surface finish control.</p>	
	<ul style="list-style-type: none"> <li>Achieve required surface finish</li> <li>Added flexibility</li> </ul>		

Least Aggressive

▶ Performance	XE	EP	GD	FD
Overall Cut	●	●	◐	○
Finish	○	○	◐	●
Flexibility	○	○	◐	●
Pressure	●	◐	◐	○

● Best ◐ Better ○ Good

# SHUR-BRITE® Surface Conditioning

## Surface Conditioning Quick Change Discs

The smaller diameters of quick change discs allow easy access to tighter areas of intricate workpieces, while maintaining a higher speed for aggressive material removal or blending. Used on right angle die grinders, quick change discs can be finessed and easily controlled for precision material removal, shaping or blending applications. Worn discs can be replaced without additional tooling, minimizing production downtime, and easing progressive finishing steps.

### Features

- ▶ Smaller footprint for intricate parts and hard to reach work areas
- ▶ Fast product changeover with no additional tooling
- ▶ High speed operation for fast results
- ▶ Can be used with oils & lubricants to further reduce heat or smearing
- ▶ Free of metallic ingredients



# X<sup>E</sup> HIGH PERFORMANCE QUICK CHANGE DISCS

For aggressive applications requiring fast material removal, or lasting performance on harder metals. Exceptional contact pressure in small, flat areas.

- ▶ Aggressive blending & removal
- ▶ Firm cutting action for flat surfaces
- ▶ Heavy deburring
- ▶ Scale removal
- ▶ Rough shaping of soft materials
- ▶ Fastest initial stock removal



Type	Diameter	Max RPM	Optimal RPM	Std. Pkg.	CRS	MED
Type S	1-1/2"	30,000	8,500	100	40412	40413
	2"	30,000	7,000	50	<b>40414</b>	<b>40415</b>
	3"	20,000	4,500	25	40416	<b>40417</b>
Type R	1-1/2"	30,000	8,500	100	40418	40419
	2"	30,000	7,000	50	<b>40420</b>	<b>40421</b>
	3"	20,000	4,500	25	<b>40422</b>	<b>40423</b>
	4"	12,000	3,500	25	41383	41384

- Ferrous
- Non-Ferrous
- Stainless
- Exotic Alloys
- Plastics
- Composites

**▶ Superior Support**

Each button type is associated with the corresponding holder and are not interchangeable.



# E<sup>P</sup> EXTENDED PERFORMANCE QUICK CHANGE DISCS

Aggressive, consistent finishing on hard, contoured surfaces. Durable edge retention and less smearing when used at tighter angles.

- ▶ Heavy blending & deburring
- ▶ High edge endurance
- ▶ Aggressive action on contours
- ▶ Consistent, heavy finishing
- ▶ Reduced heat on hard metals

Type	Diameter	Max RPM	Optimal RPM	Std. Pkg.	CRS	MED
Type S	1-1/2"	30,000	8,500	100	52332	52339
	2"	30,000	7,000	50	50760	50761
	3"	20,000	4,500	25	50762	50763
Type R	1-1/2"	30,000	8,500	100	52338	52340
	2"	30,000	7,000	50	<b>50764</b>	<b>50765</b>
	3"	20,000	4,500	25	<b>50758</b>	<b>50766</b>
	4"	12,000	3,500	25	51811	52290

- Ferrous
- Non-Ferrous
- Stainless
- Exotic Alloys
- Plastics
- Composites

**▶ Superior Support**

Material grades are determined by the size of abrasive grains, not the density or flexibility of the product. Using the same grain size within higher fiber or resin content will produce different, and sometimes unexpected results.

# SHUR-BRITE® Surface Conditioning

## GD GRIND DUTY QUICK CHANGE DISCS



A balanced density of grains and resin offer a controlled cut rate on harder metals and less loading on softer materials. Moderate cushion and flexibility reduces gouging or marring on all flat surfaces and contours.

- ▶ Blending coated scratch patterns
- ▶ Equal performance on flat or contoured surfaces
- ▶ Reduced risk of gouging softer materials
- ▶ Consistent performance
- ▶ Several grades available for progressive finishing

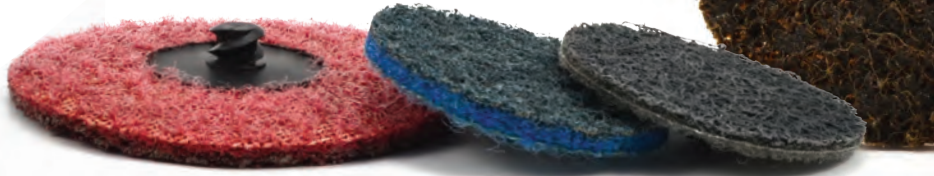

Type	Diameter	Max RPM	Optimal RPM	Std. Pkg.	CRS	MED	VFN	SFN
Type S	1-1/2"	30,000	8,500	100	<b>10541B</b>	<b>10542B</b>	<b>10543B</b>	38456B
	2"	30,000	7,000	50	<b>10544B</b>	<b>10545B</b>	<b>10546B</b>	38457B
	3"	20,000	4,500	25	<b>10547B</b>	<b>10548B</b>	<b>10549B</b>	38458B
Type R	1-1/2"	30,000	8,500	100	<b>10550B</b>	<b>10551B</b>	<b>10552B</b>	38459B
	2"	30,000	7,000	50	<b>10553B</b>	<b>10554B</b>	<b>10555B</b>	<b>38460B</b>
	3"	20,000	4,500	25	<b>10556B</b>	<b>10557B</b>	<b>10558B</b>	<b>38461B</b>
	4"	12,000	3,500	25	<b>32120B</b>	<b>18354B</b>	18353B	41382B

● Ferrous ● Non-Ferrous ● Stainless ● Exotic Alloys ○ Plastics ○ Composites

## FD FINISH DUTY QUICK CHANGE DISCS



Primarily used for surface finishing and preparation, FD quick change discs provide a consistent cutting rate and repeatable finish on stainless steels and non-ferrous metals. Cooler temperatures are maintained, resulting in longer life for uninterrupted application.

- ▶ Achieve required surface finishes
- ▶ Progressive scratch removal
- ▶ Surface treatment & preparation
- ▶ Added flexibility



Type	Diameter	Max RPM	Optimal RPM	Std. Pkg.	CRS	MED	VFN	SFN
Type S	1-1/2"	30,000	8,500	100	10541	<b>10542</b>	<b>10543</b>	38456
	2"	30,000	7,000	50	<b>10544</b>	<b>10545</b>	<b>10546</b>	38457
	3"	20,000	4,500	25	<b>10547</b>	<b>10548</b>	<b>10549</b>	38458
Type R	1-1/2"	30,000	8,500	100	<b>10550</b>	<b>10551</b>	<b>10552</b>	38459
	2"	30,000	7,000	50	<b>10553</b>	<b>10554</b>	<b>10555</b>	<b>38460</b>
	3"	20,000	4,500	25	<b>10556</b>	<b>10557</b>	<b>10558</b>	<b>38461</b>
	4"	12,000	3,500	25	<b>32120</b>	<b>18354</b>	18353	41382

● Ferrous ● Non-Ferrous ● Stainless ● Exotic Alloys ● Plastics ● Composites





## QUICK CHANGE DISC HOLDERS



Type	Diameter	Shank	Max RPM	Std. Pkg.	SOFT	MEDIUM	FIRM
Type S	3/4"	1/4"	40,000	1	-	11169	-
	1"	1/4"	40,000	1	-	<b>11170</b>	-
	1-1/2"	1/4"	30,000	1	50257	<b>11171</b>	46310
	2"	1/4"	30,000	1	<b>11172</b>	<b>11173</b>	<b>11174</b>
	3"	1/4"	20,000	1	<b>11175</b>	<b>11176</b>	<b>11177</b>
	4"	1/4"	12,000	1	-	11178	-
Type R	3/4"	1/4"	40,000	1	-	<b>40564</b>	-
	1"	1/4"	40,000	1	-	<b>11273</b>	-
	1-1/2"	1/4"	30,000	1	50258	<b>11274</b>	51082
	2"	1/4"	30,000	1	<b>50254</b>	<b>11275</b>	<b>40821</b>
	3"	1/4"	20,000	1	<b>50420</b>	<b>11276</b>	<b>38308</b>
	4"	1/4"	12,000	1	-	<b>34992</b>	-

### ► Superior Support

For added flexibility on inside contours, try using an undersized holder. Pressure and aggression will be compromised, but you may reach tighter areas.

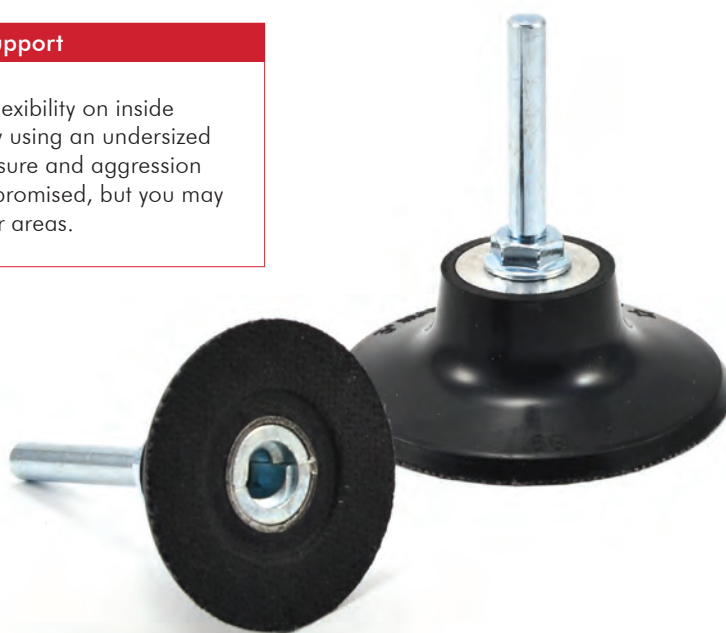

# SHUR-BRITE® Surface Conditioning

## Surface Conditioning Hook & Loop Discs

For removal, blending, surface preparation and finishing of larger areas, the hook and loop attachment system safely secures larger diameter discs to multiple tools. Compared to smaller quick change discs, full surface treatments of larger workpieces can be completed with less changeover, and product or operator fatigue. Best for flat and moderately contoured surfaces, materials available are well suited for a variety of industrial applications.

### Features

- ▶ Fastening system secures discs in place without tooling
- ▶ Ideal for large, flat or accessible areas
- ▶ Refine surface patterns with orbital sanders
- ▶ Larger diameter material coverage easily blends in fewer steps for faster results
- ▶ Can be used with oils & lubricants to further reduce heat or smearing
- ▶ Free of metallic ingredients

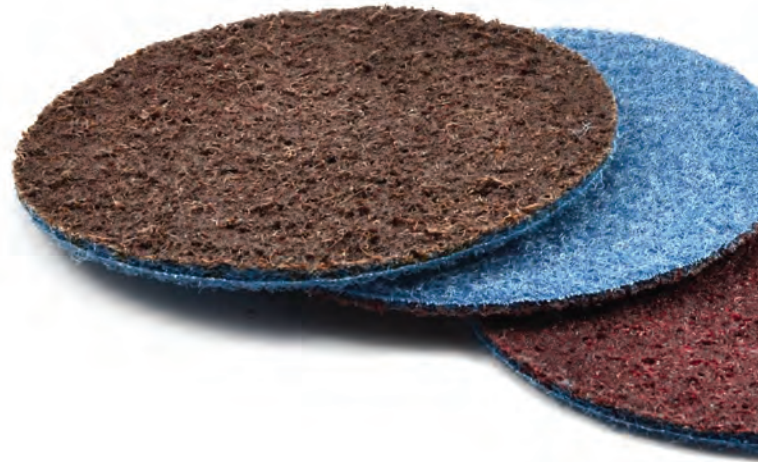

## X<sup>E</sup> HIGH PERFORMANCE HOOK & LOOP DISCS



For aggressive, larger scale applications requiring fast material removal, or lasting performance on harder metals. Best for smoothing or shaping harsh angles or surface imperfections.

- ▶ Heavy blending & spatter removal
- ▶ Exceptional contact pressure for harder metals
- ▶ Large scale rust & oxide removal
- ▶ Heavy deburring & shaping

Diameter	Max RPM	Optimal RPM	Std. Pkg.	CRS	MED
4"	8,000	3,300	20	<b>40402</b>	<b>40403</b>
4-1/2"	8,000	3,000	20	<b>40404</b>	<b>40405</b>
5"	7,000	2,600	20	<b>40406</b>	<b>40407</b>
7"	6,000	1,800	20	<b>40408</b>	<b>40409</b>

● Ferrous ○ Non-Ferrous ● Stainless ● Exotic Alloys ○ Plastics ○ Composites

## E<sup>P</sup> EXTENDED PERFORMANCE HOOK & LOOP DISCS



Consistent surface refinement and finishing on harder metals. Durable edge retention for heavy, inside diameter deburring or weld removal.

Diameter	Max RPM	Optimal RPM	Std. Pkg.	CRS	MED
4"	8,000	3,300	20	<b>52375</b>	<b>52376</b>
4-1/2"	8,000	3,000	20	<b>50843</b>	<b>52378</b>
5"	7,000	2,600	20	<b>51543</b>	<b>51544</b>
7"	6,000	1,800	20	<b>50844</b>	<b>51408</b>

● Ferrous ○ Non-Ferrous ● Stainless ● Exotic Alloys ○ Plastics ○ Composites

- ▶ Heavy blending & removal
- ▶ High edge endurance
- ▶ Aggressive action on contours & inside corners
- ▶ Consistent finishing with long life
- ▶ Reduced heat on hard metals

# SHUR-BRITE® Surface Conditioning

## GD GRIND DUTY HOOK & LOOP DISCS

Controlled cut rate and surface finishing range on harder metals. Balanced density of grains and resin reduce heat generation, loading and smearing on both hard or soft materials.

- ▶ Blending or refining scratch patterns
- ▶ Moderate cushion and flexibility
- ▶ Reduced risk of gouging soft materials
- ▶ Consistent performance
- ▶ Several grades available for progressive finishing

**▶ Superior Support**

Super Fine (SFN) materials contain Silicon Carbide (S/C) abrasives, which produce sharper, finer cuts, resulting in brighter finishes.



CRS (A/O)



SFN (S/C)

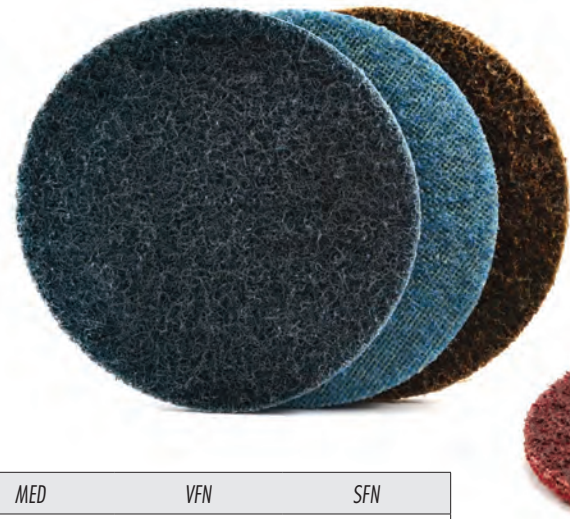

Diameter	Max RPM	Optimal RPM	Std. Pkg.	CRS	MED	VFN	SFN
4"	8,000	3,300	20	<b>10577B</b>	<b>10578B</b>	<b>10579B</b>	38799B
4-1/2"	8,000	3,000	20	<b>10580B</b>	<b>10581B</b>	<b>10582B</b>	38800B
5"	7,000	2,600	20	<b>10583B</b>	<b>10584B</b>	<b>10585B</b>	38801B
7"	6,000	1,800	20	<b>10589B</b>	<b>10590B</b>	10591B	38802B

● Ferrous   ● Non-Ferrous   ● Stainless   ● Exotic Alloys   ○ Plastics   ○ Composites

## FD FINISH DUTY HOOK & LOOP DISCS

For surface preparation or finishing with measured, repeatable results on stainless steels and non-ferrous metals. Cooler temperatures are maintained, resulting in longer life for larger surface areas.

- ▶ Achieve required surface finishes
- ▶ Progressive scratch removal
- ▶ Fine blending & smoothing
- ▶ Surface treatment & preparation

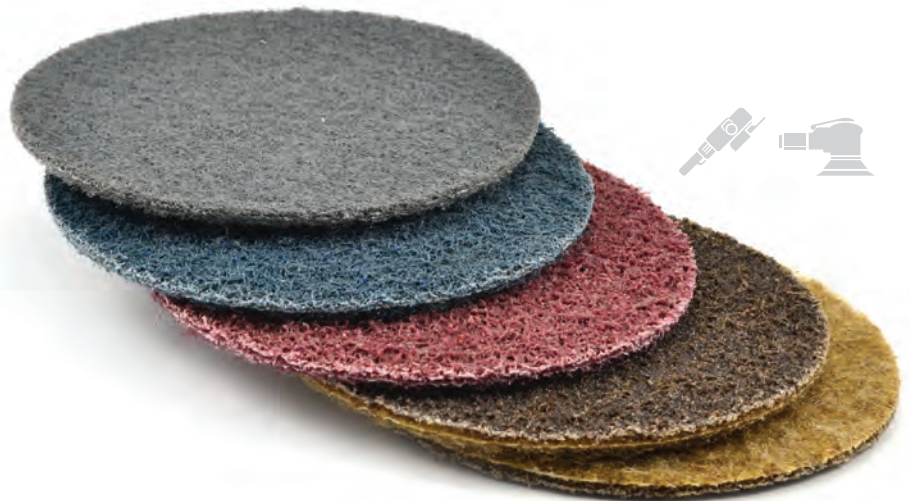

Diameter	Max RPM	Optimal RPM	Std. Pkg.	CRS	MED	VFN	SFN
4"	8,000	3,300	20	10577	10578	10579	38799
4-1/2"	8,000	3,000	20	<b>10580</b>	<b>10581</b>	<b>10582</b>	38800
5"	7,000	2,600	20	<b>10583</b>	<b>10584</b>	<b>10585</b>	38801
7"	6,000	1,800	20	<b>10589</b>	<b>10590</b>	<b>10591</b>	38802

● Ferrous   ● Non-Ferrous   ● Stainless   ● Exotic Alloys   ● Plastics   ● Composites

▶ Superior Support

The "hooks" of the pad grab the fibers, or "loops" of the disc.

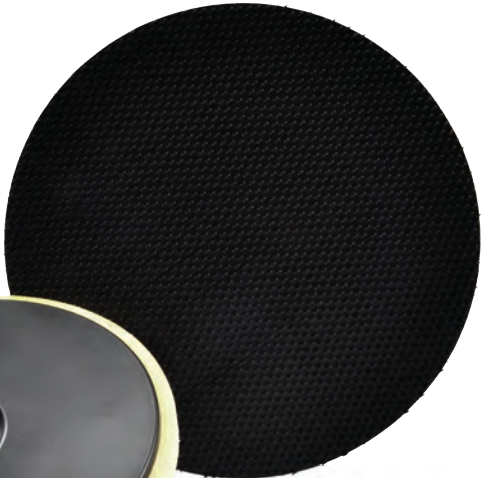

HOOK & LOOP DISC HOLDERS



Diameter	Arbor/Shank	Connector	Max RPM	Std. Pkg.	Part #
4"	1/4"	Male	11,000	1	<b>10598</b>
4"	5/8"-11	Female	10,000	1	<b>10599</b>
4-1/2"	5/8"-11	Female	10,000	1	<b>10600</b>
5"	5/8"-11	Female	10,000	1	<b>10601</b>
5"	5/16"-24	Male	10,000	1	<b>10602</b>
7"	5/8"-11	Female	4,800	1	<b>10605</b>



# SHUR-BRITE® Surface Conditioning

## GD GRIND DUTY HOOK & LOOP CENTER HOLE DISCS



An assisted-centering arbor hole ensures consistent disc alignment every change-over. Use on right angle grinders with rubber backing pad and retainer nut, for higher rotational speed.

Controlled cut rate and surface finishing range on harder metals. Balanced density of grains and resin reduce heat generation, loading and smearing on both hard or soft materials.

- ▶ Blending or refining scratch patterns
- ▶ Moderate cushion and flexibility
- ▶ Reduced risk of gouging soft materials
- ▶ Consistent performance



### ▶ Superior Support

Utilizing the same hardware as Resin Fiber Discs, the transition to finishing coated scratch patterns is even easier with Center Hole Discs.

Diameter	Arbor	Max RPM	Optimal RPM	Std. Pkg.	CRS	MED
4-1/2"	7/8"	8,000	3,000	20	<b>41323B</b>	42774B
5"	7/8"	7,000	2,600	20	<b>27147B</b>	35599B

● Ferrous   ● Non-Ferrous   ● Stainless   ● Exotic Alloys   ○ Plastics   ○ Composites

## FD FINISH DUTY HOOK & LOOP CENTER HOLE DISCS



For surface preparation or finishing with measured, repeatable results on stainless steels and non-ferrous metals. Cooler temperatures are maintained, resulting in longer life for larger surface areas.

An assisted-centering arbor hole ensures consistent disc alignment every change-over. Use on right angle grinders with rubber backing pad and retainer nut, for higher rotational speed.

- ▶ Achieve required surface finishes
- ▶ Progressive scratch removal
- ▶ Fine blending & smoothing
- ▶ Surface treatment & preparation



Diameter	Arbor	Max RPM	Optimal RPM	Std. Pkg.	CRS	MED
4-1/2"	7/8"	8,000	3,000	20	<b>41323</b>	42774
5"	7/8"	7,000	2,600	20	27147	35599

● Ferrous ● Non-Ferrous ● Stainless ● Exotic Alloys ● Plastics ● Composites

### ▶ Superior Support

Solid rubber backing pads reduce the amount of available cushion, but increase in flexibility, sometimes allowing for easier blending finesse and better transitions.

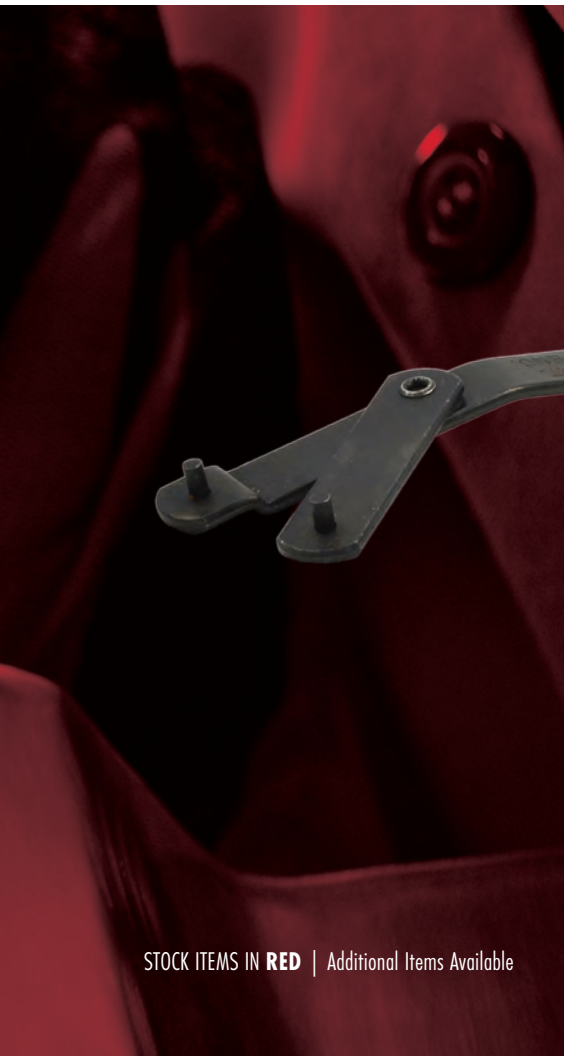

## HOOK & LOOP CENTER HOLE DISC HOLDERS



Diameter	Arbor	Max RPM	Std. Pkg.	Part #
4-1/2"	5/8"-11	13,500	1	<b>11847</b>
5"	5/8"-11	13,000	1	<b>11850</b>
Retainer Nut			1	<b>11858</b>
Spanner Wrench			1	<b>11859</b>

\*Nut and wrench not supplied with disc holder.

STOCK ITEMS IN **RED** | Additional Items Available

● Best ● Better ○ Good

[www.superiorabrasives.com](http://www.superiorabrasives.com)

# SHUR-BRITE® Surface Conditioning

## Surface Conditioning Flap Discs

Designed to utilize the added leverage and increased contact pressure of right angle grinders. Manufactured with a fiberglass plate, no backing pad is necessary, and a threaded hub option provides fast changeover without additional tooling. Surface conditioning flaps overlap radially, increasing airflow and reducing loading or burning during operation.

### Features

- ▶ Use on angle grinder without backing pad
- ▶ Designed for focused contact pressure
- ▶ Firm cutting action for flat surfaces
- ▶ Blend coated abrasive scratch patterns
- ▶ Weld and seam blending or cleaning

#### ▶ Superior Support

Surface conditioning flap discs are only available as Type 27 - Flat Face, ideal for up to 15° working angle on flat surfaces.

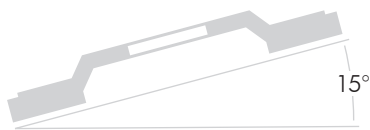

## **G<sup>D</sup>** GRIND DUTY FLAP DISCS



Diameter	Arbor	Max RPM	Optimal RPM	Std. Pkg.	CRS	MED	VFN
4-1/2"	7/8"	13,300	5,800	5	<b>46582</b>	<b>46583</b>	<b>46584</b>
4-1/2"	5/8"-11	13,300	5,800	5	46640	46641	46642

● Ferrous   ● Non-Ferrous   ● Stainless   ● Exotic Alloys   ○ Plastics   ○ Composites

SUPERIOR ABRASIVES, LLC.  
(800) 235-9123

● Best   ● Better   ○ Good

Additional Items Available | STOCK ITEMS IN RED



## Surface Conditioning Stars

Applying the flexibility of FD Surface Conditioning materials, mandrel mounted stars easily conform to hard-to-reach tube, pipe or other inside diameter cylindrical parts. The light weight and flexibility prevents gouging, marring, or unintentionally changing the dimensions of the workpiece.

### Features

- ▶ Deburring cut tube or drilled holes
- ▶ Inside diameter smoothing, cleaning & polishing
- ▶ Cleaning or chamfering recessed areas

#### ▶ Superior Support



Flex shaft tools are used for extended depths or routing stars through curved tubing or pipe. Mandrel extensions are used well for boring & shaping, cleaning or deburring of tubes, drilled holes or cylindrical parts of moderate depth or slightly out of reach.



## FD FINISH DUTY MANDREL MOUNTED STARS

Diameter	Eyelet	Max RPM	Optimal RPM	Std. Pkg.	CRS	MED	VFN
1-1/2"	1/4"-20	23,000	8,500	50	<b>28832</b>	<b>28833</b>	<b>28834</b>
2"	1/4"-20	23,000	7,000	50	<b>28835</b>	<b>28836</b>	<b>28837</b>
3"	1/4"-20	20,000	4,500	25	<b>28838</b>	<b>28839</b>	28840
4"	1/4"-20	12,000	3,500	25	<b>28841</b>	28842	28843

● Ferrous ● Non-Ferrous ● Stainless ● Exotic Alloys ● Plastics ● Composites



## EYELET MANDRELS

Rust proof black oxide finish. Quickly secures to stars.

Overall Length	Shank Diameter	Fits Thread	Std. Pkg.	Part #
3"	1/4"	1/4"-20	1	<b>12219</b>
6"	1/4"	1/4"-20	1	<b>42815</b>



## MANDREL EXTENSIONS

Overall Length	Shank Diameter	Fits Thread	Std. Pkg.	Part #
4"	1/4"	1/4"-20	1	<b>39207</b>
6"	1/4"	1/4"-20	1	<b>39208</b>
8"	1/4"	1/4"-20	1	<b>39209</b>

# SHUR-BRITE® Surface Conditioning

## Surface Conditioning Belts

The open structure of surface conditioning belts resists overheating, part discoloration or loading, ensuring consistent quality throughout life - important factors when decorating or finishing large surface areas.

In narrow or short form, like file belts, the surface conditioning material is manufactured with additional flex, easily conforming to small contact wheels and narrow areas of the workpiece. Wide belts utilize a low stretch reinforcement, providing stability and reduced changeover on large, robotic equipment.

### Features

- ▶ High edge durability and flexibility without chunking
- ▶ Create linear scratch patterns on stainless food equipment
- ▶ Smear-free removal of oxidation, paint or adhesives
- ▶ Blend or reorient surface scratch patterns after repair
- ▶ Repeatable finishes for large scale robotic applications



## X<sup>F</sup> FLEX BELTS



A variety of sizes available for use with small contact wheels to access intricate areas. Exceptional flexibility and edge durability for detail work over contours and corners.

- ▶ Thin, pliable reinforcement
- ▶ Flexible over small contact wheels
- ▶ Conforms to smaller areas

Width	Length	Std. Pkg.	CRS	MED	VFN
1/2"	12"	24	33791	<b>32352</b>	32361
1/2"	18"	24	<b>10607</b>	<b>10608</b>	<b>10609</b>
1/2"	24"	24	<b>10610</b>	<b>10611</b>	<b>10612</b>
3/4"	18"	16	<b>10613</b>	<b>10614</b>	<b>10615</b>
3/4"	20-1/2"	16	<b>10616</b>	<b>10617</b>	<b>10618</b>
3"	21"	8	21341	21342	24603
3"	24"	8	10646	10647	10648
3-1/2"	15-1/2"	10	<b>10622</b>	<b>10623</b>	<b>10624</b>

● Ferrous ● Non-Ferrous ● Stainless ● Exotic Alloys ● Plastics ● Composites

**\*Also available in FINE**

## L<sup>S</sup> LOW STRETCH BELTS



Reduced stretching and high edge retention ensures durability and consistent performance throughout use. Reduced heat generation provides long life.

- ▶ Tightly-woven reinforcement reduces stretching
- ▶ Consistency in operational performance

Width	Length	Std. Pkg.	CRS	MED	VFN
1"	42"	12	<b>10625</b>	<b>10626</b>	<b>10627</b>
1"	72"	12	44383	43883	27457
1"	132"	12	18434	18435	44125
2"	48"	6	<b>10628</b>	<b>10629</b>	<b>10630</b>
2"	60"	6	10631	10632	10633
2"	72"	6	10634	<b>10635</b>	<b>10636</b>
2"	132"	6	10637	10638	10639
2-1/2"	60"	4	10643	<b>10644</b>	10645
3"	132"	4	10649	<b>10650</b>	10651
4"	54"	6	10658	10659	10660
4"	132"	3	10661	10662	10663
4"	168"	3	40627	38894	40628
6"	48"	4	<b>10664</b>	<b>10665</b>	<b>10666</b>

● Ferrous ● Non-Ferrous ● Stainless ● Exotic Alloys ● Plastics ● Composites

**\*Also available in FINE**





# SHUR-BRITE® Satin Finishing

### Satin Finishing Characteristics

Made without a scrim reinforcement, SHUR-BRITE® Satin Finishing, or fleece, materials are lighter, more pliable and conformable than other nonwoven materials. Satin materials contain stronger nylon fibers and additional resin content in place of a reinforced weave. On their own, fleece materials can be used flat or on edge. With added manufacture, satin finishing products can be made for directional use only, matching the benefits of the product form to the application of fleece materials.

### Satin Finishing Features

Satin products are softer and more conformable than surface conditioning products and well suited for general cleaning, blending or finishing. Also used to achieve a desired or required finish, many product forms are available to service flat, contoured, concave or cylindrical parts.

Available with both Aluminum Oxide (A/O) or Silicon Carbide (S/C) grains, final finishes can range from matte to high luster. Each grain offers unique characteristics, expanding the versatility of satin finishing materials and their products.

- ▶ Conformability to the workpiece
- ▶ Consistent performance throughout extended life
- ▶ Resistance to loading
- ▶ Suitable for wet or dry applications

### Applications

- ▶ Light deburring of intricately cast parts
- ▶ Blemish removal caused by tooling or handling
- ▶ Removal of light surface oxidation & corrosion
- ▶ Reducing or blending fine scratch patterns
- ▶ Flash removal from non-metallic composites
- ▶ Gear & thread cleaning or micro-deburring
- ▶ Stainless steel cleaning & grain finishing
- ▶ Low polish or low luster decorative finishing

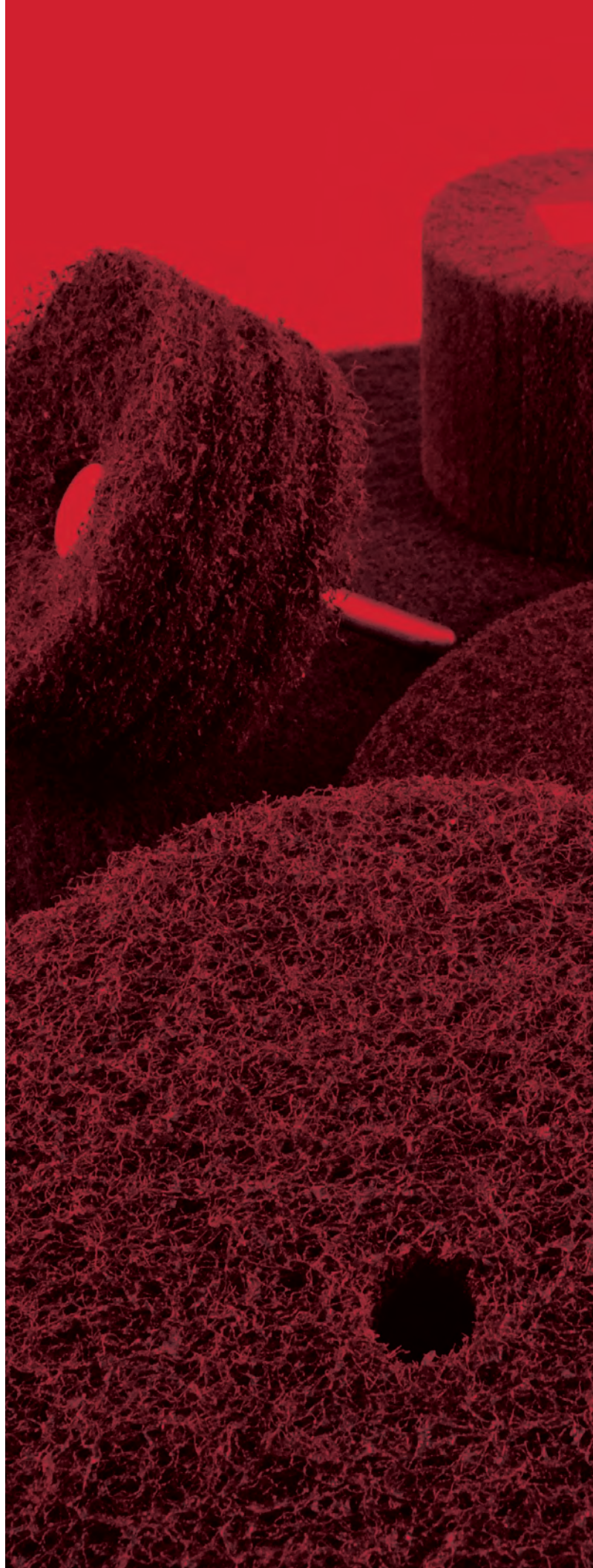

The versatility of satin finishing materials can be utilized in more forms than other nonwovens, including discs, goblets, flap brushes, stars, hand pads, flap, and duplex wheels, with alternating flaps of coated abrasives.

Durability	<b>HS</b> High Strength	Resin reinforced nylon fibers provide durability and strength for high speed operation.				
	<b>HP</b> Heavy Duty	Flexible resin and high grain content promote conformability and cushion for fine tolerances.				
		<table border="1" style="width: 100%; border-collapse: collapse;"> <tr> <th style="background-color: #e0e0e0; padding: 2px;">Aluminum Oxide (A/O)</th> <th style="background-color: #e0e0e0; padding: 2px;">Silicon Carbide (S/C)</th> </tr> <tr> <td style="padding: 2px;"> <ul style="list-style-type: none"> <li>Long life</li> <li>Durable, general purpose</li> <li>Withstands high pressure</li> </ul> </td> <td style="padding: 2px;"> <ul style="list-style-type: none"> <li>Fast cut, uniform finish</li> <li>Sharper, finer cut</li> <li>Achieve required finishes</li> </ul> </td> </tr> </table>	Aluminum Oxide (A/O)	Silicon Carbide (S/C)	<ul style="list-style-type: none"> <li>Long life</li> <li>Durable, general purpose</li> <li>Withstands high pressure</li> </ul>	<ul style="list-style-type: none"> <li>Fast cut, uniform finish</li> <li>Sharper, finer cut</li> <li>Achieve required finishes</li> </ul>
Aluminum Oxide (A/O)	Silicon Carbide (S/C)					
<ul style="list-style-type: none"> <li>Long life</li> <li>Durable, general purpose</li> <li>Withstands high pressure</li> </ul>	<ul style="list-style-type: none"> <li>Fast cut, uniform finish</li> <li>Sharper, finer cut</li> <li>Achieve required finishes</li> </ul>					
<b>CF</b> Clean & Finish	Balanced resin and grain content for flexibility and conformability in flat applications.					
Conformability	<b>CF</b> Clean & Finish	<table border="1" style="width: 100%; border-collapse: collapse;"> <tr> <th style="background-color: #e0e0e0; padding: 2px;">Aluminum Oxide (A/O)</th> <th style="background-color: #e0e0e0; padding: 2px;">Silicon Carbide (S/C)</th> </tr> <tr> <td style="padding: 2px;"> <ul style="list-style-type: none"> <li>Long life</li> <li>Durable, general purpose</li> <li>Reduced loading</li> </ul> </td> <td style="padding: 2px;"> <ul style="list-style-type: none"> <li>Sharp, fine cut and finish</li> <li>Match or blend existing surface finishes</li> </ul> </td> </tr> </table>	Aluminum Oxide (A/O)	Silicon Carbide (S/C)	<ul style="list-style-type: none"> <li>Long life</li> <li>Durable, general purpose</li> <li>Reduced loading</li> </ul>	<ul style="list-style-type: none"> <li>Sharp, fine cut and finish</li> <li>Match or blend existing surface finishes</li> </ul>
		Aluminum Oxide (A/O)	Silicon Carbide (S/C)			
<ul style="list-style-type: none"> <li>Long life</li> <li>Durable, general purpose</li> <li>Reduced loading</li> </ul>	<ul style="list-style-type: none"> <li>Sharp, fine cut and finish</li> <li>Match or blend existing surface finishes</li> </ul>					

▶ Performance	HS	HD	CF
Cut	●	◐	○
Life	●	◐	○
Finish	◐	●	◐
Flexibility	○	◐	●
Pressure	●	◐	○
Density	●	◐	○

● Best ◐ Better ○ Good

# SHUR-BRITE® Satin Finishing

## Satin Finishing Discs

Due to the high strength nylon fibers and resin content, satin finishing discs can withstand higher rotational speed in both stationary or portable use, for flat or on-edge application. Both quick change and arbor mounted options are available for use with small or intricate parts to larger contours.

### Features

- ▶ Easily conforms to acute or inaccessible areas
- ▶ Cushion and control for critical tolerance and finesse
- ▶ Protection from gouging or marring workpieces
- ▶ Varying grades and densities for a wide range of applications

## HS HIGH STRENGTH SATIN QUICK CHANGE DISCS

Durable and long-lasting finishing when a higher cut rate is necessary. Strong fibers resist snagging or tearing on intricate parts and can handle higher applied pressure. The quick change holder provides directional pressure from the tool for better control and off-hand finesse.

- ▶ Edge deburring on extrusions
- ▶ Finishing brass or steel stampings
- ▶ Final finishing of intricate aerospace parts

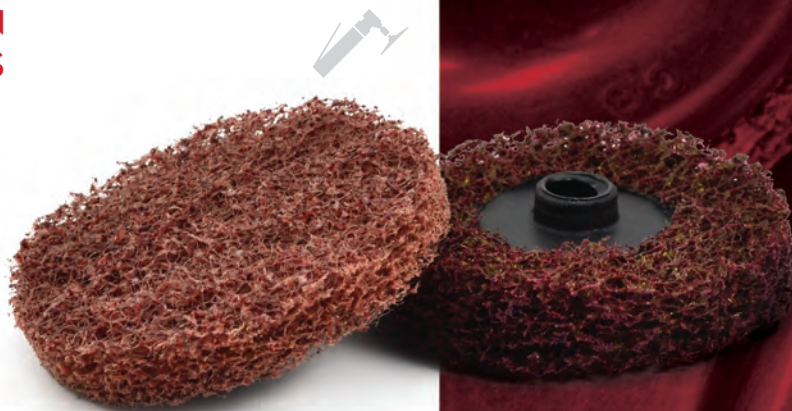

Type	Diameter	Max RPM	Optimal RPM	Std. Pkg.	MED	FINE	VFN
Type S	2"	12,000	7,000	50	<b>46588</b>	<b>46589</b>	46590
	3"	8,000	4,500	25	46591	46592	46593
Type R	2"	12,000	7,000	50	<b>38857</b>	<b>38858</b>	<b>38859</b>
	3"	8,000	4,500	25	<b>38860</b>	<b>38861</b>	<b>38862</b>

● Ferrous   ● Non-Ferrous   ● Stainless   ● Exotic Alloys   ○ Plastics   ● Composites

SUPERIOR ABRASIVES, LLC.  
(800) 235-9123

● Best   ● Better   ○ Good

Additional Items Available | STOCK ITEMS IN RED



## HPD HEAVY DUTY SATIN QUICK CHANGE DISCS

Less dense and aggressive than HS quick change discs, finer grades are reinforced with a cloth backing. For light cleaning or finishing, suitable for soft materials.

- ▶ Decorative blending or finishing
- ▶ Oxidation removal from small areas
- ▶ Micro-deburring or seam cleaning
- ▶ From matte finish to low polish



Type	Diameter	Max RPM	Optimal RPM	Std. Pkg.	CRS	MED	FINE	VFN
Type S	2"	12,000	7,000	50	<b>10511</b>	<b>10512</b>	<b>10513</b>	<b>10514</b>
	3"	8,000	4,500	25	10515	<b>10516</b>	10517	10518
Type R	2"	12,000	7,000	50	38213	<b>40170</b>	46649	38214
	3"	8,000	4,500	25	40508	39911	46585	39931

● Ferrous ● Non-Ferrous ● Stainless ○ Exotic Alloys ● Plastics ● Composites



## QUICK CHANGE DISC HOLDERS

Type	Diameter	Shank	Max RPM	Std. Pkg.	Part #
Type S	2"	1/4"	30,000	1	<b>11173</b>
	3"	1/4"	20,000	1	<b>11176</b>
Type R	2"	1/4"	30,000	1	<b>11275</b>
	3"	1/4"	20,000	1	<b>11276</b>



# SHUR-BRITE® Satin Finishing

## HS HIGH STRENGTH SATIN ARBOR MOUNTED DISCS

Durable and long-lasting deburring, cleaning and finishing. Strong fibers resist snagging or tearing on intricate parts and can handle higher applied pressure. Can be stacked on mounting spindle to increase surface area for larger areas.

- ▶ Edge breaking or deburring
- ▶ Light rust & oxidation removal
- ▶ Decorative or final finishing



Diameter	Arbor	Max RPM	Optimal RPM	Std. Pkg.	MED	FINE	VFN
6"	1/2"	3,600	2,000	25	<b>34470</b>	<b>40610</b>	<b>40611</b>
8"	1/2"	2,700	1,500	25	<b>21554</b>	<b>40612</b>	<b>40613</b>

● Ferrous   ● Non-Ferrous   ● Stainless   ● Exotic Alloys   ○ Plastics   ● Composites

### ▶ Superior Support

Arbor mounted discs can be stacked on stationary spindles to increase active surface area.

## HD HEAVY DUTY SATIN ARBOR MOUNTED DISCS

Less dense and aggressive than HS discs, best for light deburring, cleaning or finishing. Lower density provides flexibility and contouring of intricate parts. Suitable for softer materials.

- ▶ Light oxidation removal
- ▶ Pipe thread or gear deburring
- ▶ Decorative finishing & blending
- ▶ From matte finish to low polish



Diameter	Arbor	Max RPM	Optimal RPM	Std. Pkg.	CRS	MED	FINE	VFN
6"	1/2"	3,600	2,000	25	46586	<b>25913</b>	<b>16120</b>	<b>17124</b>
8"	1/2"	2,700	1,500	25	46587	<b>10531</b>	<b>10532</b>	10533

● Ferrous   ● Non-Ferrous   ● Stainless   ○ Exotic Alloys   ● Plastics   ● Composites

### Wheels for Angle Grinders

Several wheels are available exclusively for right angle and variable speed angle grinders, taking advantage of the familiarity and ease of use of the tool. Larger areas can be cleaned, prepped or finished faster, and multiple operations can be achieved without changing tools. Wheels specifically made for angle grinders are a convenient alternative to flap drums and their required linear finishing tools.

#### Features

- ▶ Linear finishing without specialized tools
- ▶ Prepare larger areas without frequent changeover
- ▶ Convenient alternative to flap drums



### HP<sup>D</sup> DUPLEX WHEELS FOR ANGLE GRINDERS



Alternating coated and satin flaps for controlled balance of aggressive finishing and cushioned finesse. Can be used on larger parts with right angle grinders.

- ▶ Coated flaps remove and clean surface imperfections
- ▶ Satin flaps blend and finish parts
- ▶ Remove & blend parting lines or small welds in one operation
- ▶ Blend or repair scratch patterns

Diameter	Width	Arbor	Max RPM	Optimal RPM	Std. Pkg.	100	180
4"	2"	5/8"-11	6,000	3,000	5	<b>54817</b>	<b>54818</b>

● Ferrous ● Non-Ferrous ● Stainless ○ Exotic Alloys ● Plastics ○ Composites

# SHUR-BRITE® Satin Finishing

## HPD SEAMLESS SATIN WHEELS FOR ANGLE GRINDERS

De-polishing and matte finishing without undesired transition lines, utilizing the operational comfort of right angle grinders. For larger, flatter surfaces, or those accessible with angle grinders.

- ▶ Prevents seams, lines and transitions
- ▶ Conformable to outside corners
- ▶ Continuous matte finishing
- ▶ De-polish non-ferrous surfaces
- ▶ Tough, aluminum oxide grains



Diameter	Width	Arbor	Max RPM	Optimal RPM	Std. Pkg.	MED	FINE	VFN
4"	2"	5/8"-11	6,000	3,000	5	<b>54819</b>	<b>54820</b>	<b>54821</b>

● Ferrous ● Non-Ferrous ● Stainless ○ Exotic Alloys ● Plastics ○ Composites

## HPD SATIN WHEELS FOR ANGLE GRINDERS

Satin flaps conform to surfaces without altering part geometry or damaging intricate features. Easily used on larger parts without frequent changeover. Made with a quick change hub for use with right angle grinders, no extra tooling necessary.

- ▶ Repair transitions or grain finishes
- ▶ Flexible and forgiving on contoured and intricate parts
- ▶ Finish or deburr larger extrusions
- ▶ Safely remove burrs on gears or coarse threads
- ▶ Produce fine scratch patterns

### ▶ Superior Support

Feed rate is more critical to surface roughness than grain size.

Diameter	Width	Arbor	Max RPM	Optimal RPM	Std. Pkg.	MED	FINE	VFN
4"	2"	5/8"-11	6,000	3,000	5	<b>54822</b>	<b>54823</b>	<b>54824</b>

● Ferrous ● Non-Ferrous ● Stainless ○ Exotic Alloys ● Plastics ○ Composites





## HD MOUNTED SEAMLESS SATIN WHEELS



Unique, seamless structure for de-polishing and matte finishing without harsh and visible transition lines, sometimes seen with traditional flap brushes. Used with die grinders on flat or slightly contoured parts.

- ▶ Prevents seams, lines and transitions
- ▶ Continuous matte finishing
- ▶ De-polish non-ferrous surfaces
- ▶ Silicon carbide available for finer finishing

Grain	Diameter	Width	Shank	Max RPM	Optimal RPM	Std. Pkg.	MED	FINE	VFN
A/O	3"	2"	1/4"	7,500	4,000	5	<b>54811</b>	<b>54812</b>	<b>54813</b>
	4"	2"	1/4"	6,000	3,000	5	<b>54805</b>	<b>54806</b>	<b>54807</b>
S/C	3"	2"	1/4"	7,500	4,000	5	<b>54814</b>	<b>54815</b>	<b>54816</b>
	4"	2"	1/4"	6,000	3,000	5	<b>54808</b>	<b>54809</b>	<b>54810</b>

● Ferrous ● Non-Ferrous ● Stainless ○ Exotic Alloys ● Plastics ○ Composites



STOCK ITEMS IN RED | Additional Items Available

● Best ● Better ○ Good

www.superiorabrasives.com

# SHUR-BRITE® Satin Finishing

## Duplex Wheels

Simultaneous cutting action from alternating coated and satin flaps for controlled balance of aggressive finishing and cushioned finesse. Conforms to slight contours and less intricate parts while still able to shape and remove material.

### Features

- ▶ Remove and blend in one operation
- ▶ Satin cushion between coated flaps
- ▶ Available for handheld or stationary use



## HPD HEAVY DUTY MOUNTED DUPLEX WHEELS



Tough but conformable wheels able to reach smaller areas and inner diameters and contours. Ideal for consolidating removal and blending steps into one operation.

- ▶ Coated flaps remove and clean surface imperfections
- ▶ Satin flaps blend and finish parts
- ▶ Easily remove and blend seams, parting lines or small welds in one operation
- ▶ Blend or repair flat or contoured scratch patterns

### ▶ Superior Support

Flap wheels are a great tool for edge breaking in hard to reach areas, which softens a sharp edge to increase the surface area for paint or coating adhesion.

Diameter	Width	Shank	Max RPM	Optimal RPM	Std. Pkg.	80	120	180
3/4"	3/4"	1/4"	15,000	10,500	5	52400	<b>52466</b>	52401
1"	1"	1/4"	15,000	10,500	5	<b>46050</b>	<b>41861</b>	<b>44615</b>
2"	1"	1/4"	13,700	9,600	5	<b>35644</b>	<b>35804</b>	<b>35795</b>
3"	1"	1/4"	8,600	6,000	5	<b>10467</b>	<b>10468</b>	<b>10469</b>
3"	2"	1/4"	8,600	6,000	5	<b>10470</b>	<b>10471</b>	<b>10472</b>

● Ferrous ● Non-Ferrous ● Stainless ○ Exotic Alloys ● Plastics ○ Composites

SUPERIOR ABRASIVES, LLC.  
(800) 235-9123

● Best ● Better ○ Good

Additional Items Available | STOCK ITEMS IN RED

## HD HEAVY DUTY UNMOUNTED DUPLEX WHEELS

Conformable, yet sturdy action for stationary equipment and smaller, hand-held parts. Easily remove surface coatings or oxidation, blend or repair finishes on which slight material removal may be necessary.

- ▶ Coated flaps remove and clean surface imperfections
- ▶ Satin flaps blend and finish parts
- ▶ Remove & blend parting lines or small welds in one operation
- ▶ Blend or repair scratch patterns



Diameter	Width	Arbor	Max RPM	Optimal RPM	Std. Pkg.	80	120	180
6"	1"	1"	3,400	2,000	5	<b>10426</b>	<b>10427</b>	<b>10428</b>
6"	2"	1"	3,400	2,000	5	<b>10429</b>	<b>10430</b>	<b>10431</b>

● Ferrous ● Non-Ferrous ● Stainless ○ Exotic Alloys ● Plastics ○ Composites

## ARBOR REDUCER BUSHINGS



Arbor Diameter	Reduced Diameter	Std. Pkg.	Part #
1"	3/4"	1 Pair	10391
1"	5/8"	1 Pair	<b>10392</b>
1"	1/2"	1 Pair	<b>10393</b>



STOCK ITEMS IN **RED** | Additional Items Available

● Best ● Better ○ Good

[www.superiorabrasives.com](http://www.superiorabrasives.com)

# SHUR-BRITE® Satin Finishing

## Disc Wheels

Due to the material profile running parallel to the work-piece, Mounted Disc Wheels are less aggressive than Flap Brushes, but produce a consistent satin finish. Disc Wheels are conformable and will not alter part geometry, ideal for removing light surface coatings or contaminants.

### Features

- ▶ Available in Heavy Duty and High Strength grades
- ▶ Conformable to contours and intricate parts
- ▶ Will not alter workpiece tolerances
- ▶ Portable, cushioned finishing and surface prep



## MOUNTED SATIN DISC WHEELS

Diameter	Width	Shank	Max RPM	Optimal RPM	Std. Pkg.	HD CRS	HS MED	HS FINE
1"	3/8"	1/8"	20,000	7,500	10	<b>46630</b>	<b>40433</b>	<b>40435</b>
1"	1/2"	1/8"	20,000	7,500	10	<b>46631</b>	<b>40434</b>	<b>40436</b>
1-1/2"	7/8"	1/8"	13,000	6,000	10	46632	<b>40437</b>	<b>40439</b>
1-1/2"	1"	1/8"	13,000	6,000	10	<b>46633</b>	<b>40438</b>	<b>40440</b>
2-3/8"	1/2"	1/4"	12,000	5,000	5	-	38182	38181
2-3/8"	1"	1/4"	12,000	5,000	5	-	<b>10459</b>	<b>10460</b>
2-3/8"	2"	1/4"	12,000	5,000	5	-	<b>10461</b>	<b>10462</b>
3"	1/2"	1/4"	8,000	4,000	5	-	<b>38178</b>	38179
3"	1"	1/4"	8,000	4,000	5	-	<b>10463</b>	<b>10464</b>
3"	2"	1/4"	8,000	4,000	5	-	<b>10465</b>	<b>10466</b>

● Ferrous ● Non-Ferrous ● Stainless ○ Exotic Alloys ● Plastics ○ Composites



### Goblet Wheels

Unique shape allows access to concave areas commonly found in molds, tanks or vats and extrusions, otherwise unreachable by discs or traditional wheels. Heavy Duty material is ideal for cleaning and preparation of seams and inside corners which may risk contamination. Large surface area for various shapes and sizes.

#### Features

- ▶ Heavy Duty material easily removes oxidation or residue
- ▶ Conformable to inner contours and concave areas
- ▶ Clean and prep tank and vat seams, lips or corners
- ▶ Great for food and dairy industries



## HPD HEAVY DUTY MOUNTED SATIN GOBLET WHEELS



Diameter	Width	Shank	Max RPM	Optimal RPM	Std. Pkg.	With Spindle		Refills	
						MED	FINE	MED	FINE
2"	2"	1/4"	12,000	5,000	1	<b>30608</b>	<b>30607</b>	<b>30612</b>	<b>30611</b>
3"	2"	1/4"	8,000	4,000	1	<b>30610</b>	<b>30609</b>	<b>30614</b>	<b>30613</b>

● Ferrous ● Non-Ferrous ● Stainless ○ Exotic Alloys ● Plastics ○ Composites

#### ▶ Superior Support

Spindle hardware is supplied, unless only the consumable abrasives need to be replaced - order the Goblet Refills.



### Flap Brushes

Flexible satin flaps conform to contoured surfaces without altering part geometry or damaging intricate features. Densely arranged flaps provide continuous cutting action throughout life, while resisting heat and loading. Shank and arbor mounted wheels are available depending on size and shape of workpieces or surface area.

### Features

- ▶ Heavy Duty material easily conforms to inner and outer contours
- ▶ Cushioned control when working with critical tolerances
- ▶ Versatility in form and application
- ▶ Dense layering of materials provides extended life



## HPD HEAVY DUTY MOUNTED SATIN FLAP BRUSHES



Easily access smaller diameters or tight contours with hand-held die grinders or flex shaft tools. Optimal for cleaning or micro-deburring inner or outer tube, pipe or fitting.

- ▶ Smaller diameters for intricate access
- ▶ Clean and finish inside diameters and through holes
- ▶ Conformable to flat, or inner and outer contours
- ▶ Flaps wear evenly for consistent finishing
- ▶ Clean or deburr threads without damage

**▶ Superior Support**

Flap Brush	Duplex Wheel	Flap Wheel
Least Aggressive		Most Aggressive

Diameter	Width	Shank	Max RPM	Optimal RPM	Std. Pkg.	CRS	MED	FINE
2"	1"	1/4"	13,000	6,000	10	<b>43850</b>	<b>26877</b>	<b>35564</b>
3"	1"	1/4"	8,600	4,000	10	<b>43851</b>	<b>26881</b>	<b>35565</b>
3"	2"	1/4"	8,600	4,000	10	<b>43852</b>	<b>26883</b>	<b>35126</b>

● Ferrous ● Non-Ferrous ● Stainless ○ Exotic Alloys ● Plastics ○ Composites

## HD HEAVY DUTY UNMOUNTED SATIN FLAP BRUSHES

Used for stationary operations, larger diameter wheels have longer flaps, resulting in flexibility and conformability. The larger surface area of unmounted wheels is also ideal for large or flat surfaces, reducing finishing time.

- ▶ Clean, finish or deburr extruded or machined parts
- ▶ Quickly deburr large pipe threads
- ▶ Repair or blend linear finishes on stainless steel
- ▶ Conformability for intricate parts



Grain	Diameter	Width	Arbor	Max RPM	Optimal RPM	Std. Pkg.	MED	FINE
A/O	6"	1"	2"	3,400	2,000	5	<b>28854</b>	<b>28855</b>
	6"	2"	2"	3,400	2,000	5	<b>28857</b>	28858
	8"	1"	3"	3,200	1,500	3	28863	<b>28864</b>
	8"	2"	3"	3,200	1,500	3	28866	28867
S/C	6"	1"	2"	3,400	2,000	5	45066	45065
	6"	2"	2"	3,400	2,000	5	46614	46615
	8"	1"	3"	3,200	1,500	3	46204	37348
	8"	2"	3"	3,200	1,500	3	46618	46619

● Ferrous ● Non-Ferrous ● Stainless ○ Exotic Alloys ● Plastics ○ Composites



## ARBOR REDUCER BUSHINGS

Arbor Diameter	Reduced Diameter	Std. Pkg.	Part #
2"	1"	1 Pair	28873
2"	5/8"	1 Pair	28872

# SHUR-BRITE® Satin Finishing

## Satin Finishing Stars

The structure of Satin Finishing materials provides cutting action from all directions, allowing stars to work well in tubes, concave areas or around tight angles. Multiple plies create more surface area to conform and flex while pushed or pulled through inside diameters.

### Features

- ▶ Clean or polish tube, pipe or cylindrical parts
- ▶ Easily reach around or under flanges
- ▶ Deburr cut tube or drilled holes
- ▶ Lightly chamfer recessed areas



# H<sup>S</sup> HIGH STRENGTH MANDREL MOUNTED STARS



Diameter	Eyelet	Ply	Max RPM	Optimal RPM	Std. Pkg.	MED	FINE	VFN
1-1/2"	1/4"-20	2	12,000	7,000	50	<b>42806</b>	<b>43847</b>	<b>42807</b>
2"	1/4"-20	2	12,000	7,000	50	<b>42808</b>	<b>43848</b>	42809
3"	1/4"-20	2	8,000	4,500	25	<b>42810</b>	43849	42811

● Ferrous ● Non-Ferrous ● Stainless ○ Exotic Alloys ● Plastics ○ Composites

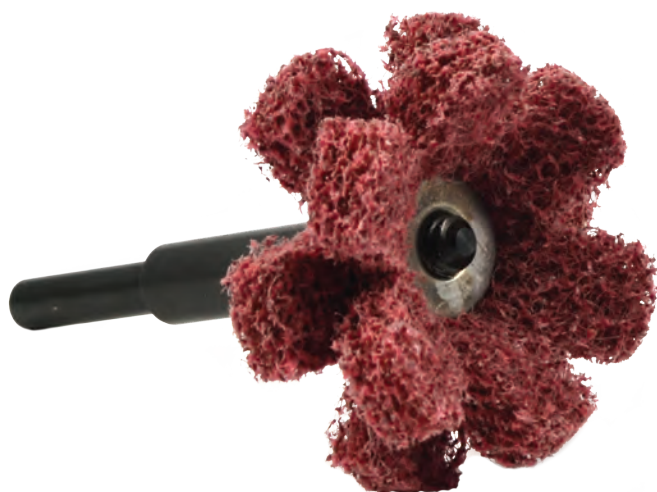

## EYELET MANDRELS



Overall Length	Shank Diameter	Fits Thread	Std. Pkg.	Part #
3"	1/4"	1/4"-20	1	<b>12219</b>
6"	1/4"	1/4"-20	1	<b>42815</b>

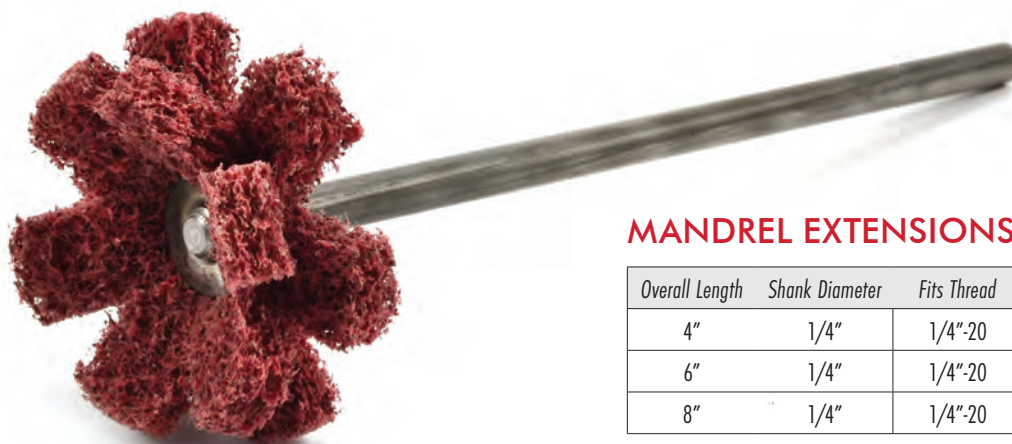

## MANDREL EXTENSIONS



Overall Length	Shank Diameter	Fits Thread	Std. Pkg.	Part #
4"	1/4"	1/4"-20	1	<b>39207</b>
6"	1/4"	1/4"-20	1	<b>39208</b>
8"	1/4"	1/4"-20	1	<b>39209</b>

# SHUR-BRITE® Satin Finishing

## CF CLEAN & FINISH HAND PADS

Sheets of Satin Finishing material can be used by hand or with a holder for multiple applications and surfaces, small to large. Non-loading material can be used with compounds for cleaning, polishing or buffing for extra versatility. General Purpose also available in special packaging.

- ▶ Used wet or dry, with most solvents
- ▶ Specialized grades for multiple applications
- ▶ Conformable to hand or workpiece



Width	Length	Std. Pkg.	General Purpose	General Purpose XS	Heavy Duty	Ultra Fine	Industrial Scouring	Stainless Steel	Non-Abrasive
6"	9"	60*	<b>10473</b>	<b>49366</b>	<b>10474</b>	<b>10475</b>	<b>10476</b>	<b>40754</b>	<b>34961</b>

● Ferrous ● Non-Ferrous ● Stainless ● Exotic Alloys ● Plastics ● Composites \*3 boxes of 20 each. No internal shrink.

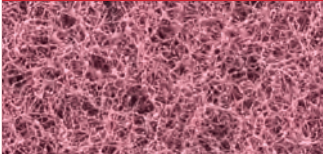
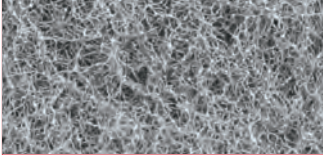
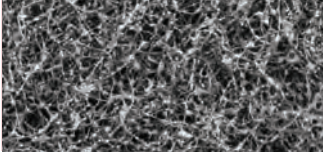
A/O General Purpose/XS	
	<ul style="list-style-type: none"> <li>▶ Blending</li> <li>▶ Light deburring</li> <li>▶ Cleaning</li> <li>▶ XS provides extended life</li> </ul>
S/C Ultra Fine	
	<ul style="list-style-type: none"> <li>▶ Decorative finishing</li> <li>▶ Jewelry</li> <li>▶ Stone polishing</li> </ul>
S/C Stainless Steel	
	<ul style="list-style-type: none"> <li>▶ Grain finish</li> <li>▶ Discoloration</li> <li>▶ Residue</li> <li>▶ Scratch patterns</li> <li>▶ Blending</li> </ul>

A/O Heavy Duty	
	<ul style="list-style-type: none"> <li>▶ Rust &amp; oxidation removal</li> <li>▶ Powder coating removal</li> <li>▶ Remove sharp burrs</li> </ul>
A/O Industrial Scouring	
	<ul style="list-style-type: none"> <li>▶ Aluminum</li> <li>▶ Stainless cleanup</li> <li>▶ Paint overspray</li> <li>▶ Oil &amp; grime</li> <li>▶ Corrosion</li> </ul>
Non-Abrasive	
	<ul style="list-style-type: none"> <li>▶ Cleaning</li> <li>▶ Buffing</li> <li>▶ Polishing compounds</li> </ul>



## SHUR-PAK HAND PADS



Width	Length	Std. Pkg.	General Purpose
6"	9"	60**	<b>34569</b>

\*\*1 bulk box. Shrink in 10's.



## HAND PAD HOLDER



Face Width	Face Length	Std. Pkg.	Part #
2-5/8"	5-3/8"	1	<b>43934</b>

**CF CLEAN & FINISH SATIN FINISHING ROLLS**

Available in extended rolls and can be cut to any size for necessary applications. Ideal for use on rotating drill or lathe operations for radial cleaning, finishing or polishing.

- ▶ Universal, cut-to-size roll lengths
- ▶ Used wet or dry, with most solvents
- ▶ Great for rotating and lathe applications
- ▶ Micro-deburring on critical parts
- ▶ General cleaning, blending or polishing

Width	Length	Std. Pkg.	A/O MED	A/O FINE	A/O VFN	S/C UFN
4"	30'	1	<b>30537</b>	<b>30538</b>	<b>30539</b>	<b>30540</b>
6"	30'	1	<b>30541</b>	30542	<b>30543</b>	30544

● Ferrous   ● Non-Ferrous   ● Stainless   ● Composites

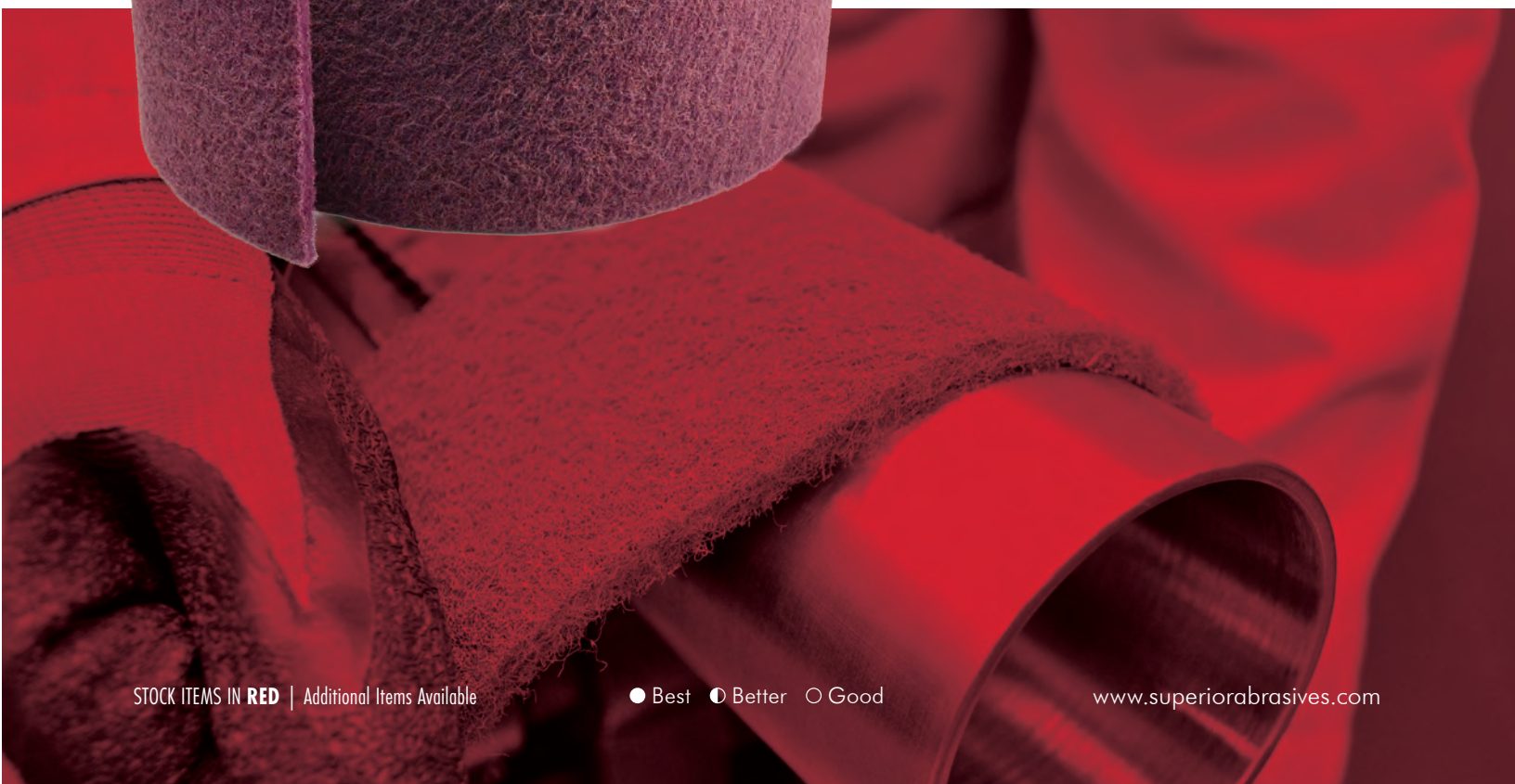
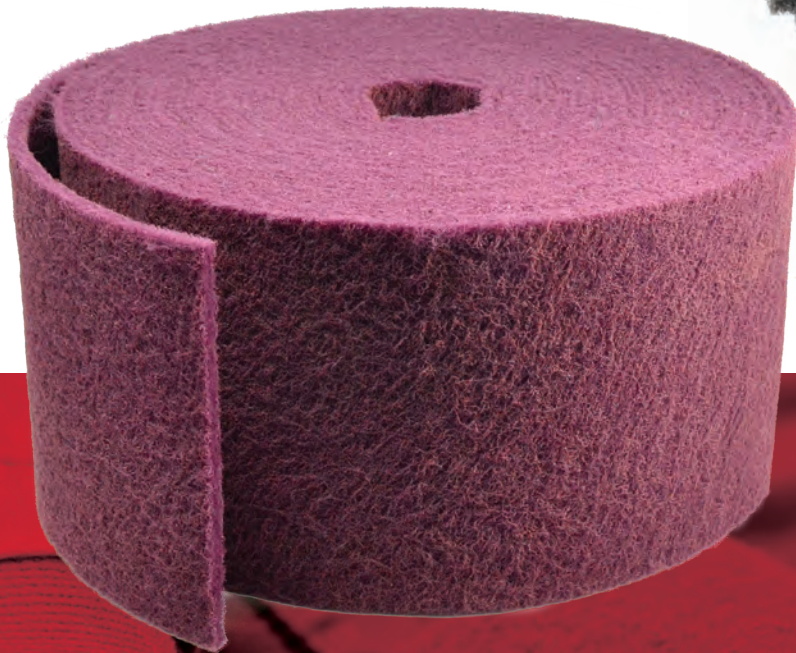







# SHUR-BRITE® Convolute

# SHUR-BRITE® Convolute

## Convolute Characteristics

Used for deburring, cleaning, blending and polishing SHUR-BRITE® Convolute Deburring Wheels utilize their compressed nonwoven structure as a three-dimensional cutting tool. Fresh abrasive grains are continually exposed, providing a consistent, uniform finish on various materials, including ferrous, non-ferrous, stainless and exotic alloys.

Nylon fibers, abrasive grains and resins are bonded together in thin layers, then convolutely wrapped around a center core. The tension of the wrap controls the density of the wheel. Due to the convolutely wrapped design, deburring wheels are one-directional and used with stationary machines.

► Understanding Material Grades		
<b>Wheel Density</b>	Wheel density also translates to flexibility and conformity. Lower densities will not alter workpiece geometry, whereas higher densities will work and remove material faster.	<p>2 ————— 9            Softer, more conformable ————— Harder, more durable            Masking/Finishing      Light Deburring/Cleaning/Finishing      Heavy Deburring</p>
<b>Grain Type</b>	Aluminum oxide grains are denser, allowing higher pressure, and recommended for softer ferrous or non-ferrous materials. Silicon carbide grains are harder and sharper, yet brittle and used with lighter pressure on harder materials, like stainless or titanium.	<p>A ————— S            Durable, long lasting ————— Sharper, finer scratch pattern            Aluminum Oxide      Silicon Carbide</p>
<b>Grain Size</b>	The abrasive grain size used in each wheel controls the depth and refinement of the scratch. Due to the nonwoven construction, convolute wheels will usually finish 2-3 grits finer than the grain size.	<p>Coarse (60-80) ————— Medium (100-150) ————— Fine (180-220)            Faster cut, rougher finish      Reduced cut rate, finer finish</p>

## Convolute Features

- ▶ Continual exposure of cutting grains & consistent finishing ability throughout extended product life
- ▶ Quality nylon fiber with high (+500°F) melting point
- ▶ Smear & heat resistant to reduce risk of discoloration
- ▶ Can be used with oils & lubricants to further reduce heat or smearing
- ▶ Free of contaminants and metallic ingredients

## Applications

- ▶ Edge breaking or radiusing
- ▶ Light corrosion, rust or oxidation removal
- ▶ Surface polishing
- ▶ Grinding of junctions on turbine blades
- ▶ Mold & die polishing
- ▶ Removal of processing traces on medical instruments

Compressed nonwoven abrasives are wrapped convolutely around a center core, producing a harder, one-directional wheel. Resin ratios and winding tension determine wheel density.



2SC

5AM

8SF

9SF

▶ Performance	2	5	7	8	9
Cut	○	○	◐	◐	●
Life	○	○	◐	◐	●
Finish	●	◐	◐	○	○
Flexibility	●	◐	◐	○	○
Pressure	○	○	○	◐	●
Density	○	○	◐	◐	●

● Best ◐ Better ○ Good



## CLEANING & DEBURRING WHEELS

Results of convolute wheels range from high luster polishing to moderate deburring, with each combination of density, grain type and size specialized in its function. The conformability of softer densities will not disrupt workpiece tolerances, while harder densities easily remove burrs or parting lines.

- ▶ Consistent, long lasting performance throughout life
- ▶ Soft densities for finishing and polishing
- ▶ Hard densities accurately remove material
- ▶ Easily access, clean and prep channels or extrusions

### ▶ Superior Support

'-R' represents added rigidity, due to the additional resin content, making 9SF-R better for heavier deburring and other operations on less intricate parts.

Diameter	Width	Arbor	Max RPM	Optimal RPM	Std. Pkg.	5AM	7SF	8SF	8AM	9SF	9SF-R
6"	1/2"	1"	6,000	2,500	4	-	-	<b>54680</b>	<b>55343</b>	<b>54681</b>	<b>55350</b>
6"	1"	1"	6,000	2,500	2	<b>54683</b>	<b>54684</b>	<b>54686</b>	<b>54685</b>	<b>54687</b>	<b>55351</b>
6"	2"	1"	6,000	2,500	1	<b>55346</b>	-	-	-	-	-
8"	1/2"	3"	4,500	1,900	4	-	<b>55356</b>	<b>54689</b>	<b>55347</b>	<b>54690</b>	<b>55348</b>
8"	1"	3"	4,500	1,900	2	<b>55349</b>	<b>54691</b>	<b>54693</b>	<b>54692</b>	<b>54694</b>	<b>55352</b>
8"	2"	3"	4,500	1,900	1	-	-	<b>54695</b>	-	<b>54696</b>	<b>55357</b>
12"	1/2"	5"	3,000	1,500	4	-	-	-	-	<b>55380</b>	<b>55381</b>
12"	1"	5"	3,000	1,500	2	<b>55360</b>	<b>55361</b>	<b>55362</b>	-	<b>55363</b>	<b>55364</b>

● Ferrous ● Non-Ferrous ● Stainless ● Exotic Alloys ● Plastics ○ Composites

## FINAL POLISHING CONVOLUTE WHEELS



Specifically designed to produce a high luster on stainless steel and mirror finishes on a variety of metals.

- ▶ Sharp silicon grains produce very fine scratch patterns
- ▶ Extra conformable for intricate parts or channels
- ▶ Consistent results throughout life
- ▶ Can be used with compounds for fine polishing



Diameter	Width	Arbor	Max RPM	Optimal RPM	Std. Pkg.	6SVF
6"	1/2"	1"	6,000	2,500	1	<b>45108</b>
6"	1"	1"	6,000	2,500	1	<b>45109</b>

● Ferrous ● Non-Ferrous ● Stainless ○ Exotic Alloys ○ Plastics ○ Composites

### ▶ Superior Support

Reduce wheel speed for higher luster or mirror polishing.

## ARBOR REDUCER BUSHINGS



Arbor Diameter	Reduced Diameter	Std. Pkg.	Part #
1"	3/4"	1 Pair	10391
1"	5/8"	1 Pair	<b>10392</b>
1"	1/2"	1 Pair	<b>10393</b>







# SHUR-BRITE® Unitized

# SHUR-BRITE®

## Unitized Characteristics

The layered, non-directional construction of SHUR-BRITE® Unitized Wheels and Discs ensures continual exposure of abrasive grains during surface preparation, cleaning, blending and polishing operations. A variety of sizes and grades are available for use with intricate components to larger workpieces. Due to the conforming nature of unitized materials, surface requirements can be achieved without affecting workpiece tolerances, and with minimal heat buildup.

## Unitized Features

- ▶ Continual exposure of cutting grains & consistent finishing ability throughout extended product life
- ▶ Quality nylon fiber with high (+500°F) melting point
- ▶ Smear & heat resistant to reduce risk of discoloration
- ▶ Can be used with oils & lubricants to further reduce heat or smearing
- ▶ Free of contaminants and metallic ingredients

## Applications

- ▶ General purpose cleaning prior to painting
- ▶ Rust, coating, scale & oxidation removal
- ▶ Edge breaking or radiusing
- ▶ Restoration polishing of molds & dies
- ▶ Deburring gears, wing spars or edge of turbine blades
- ▶ Surface refinement of airfoils, turbines & vanes
- ▶ Polishing fillet areas on turbines & aircraft parts
- ▶ Cleaning or removing micro-burrs on gears & threads
- ▶ Polishing or finishing surgical instruments or implants

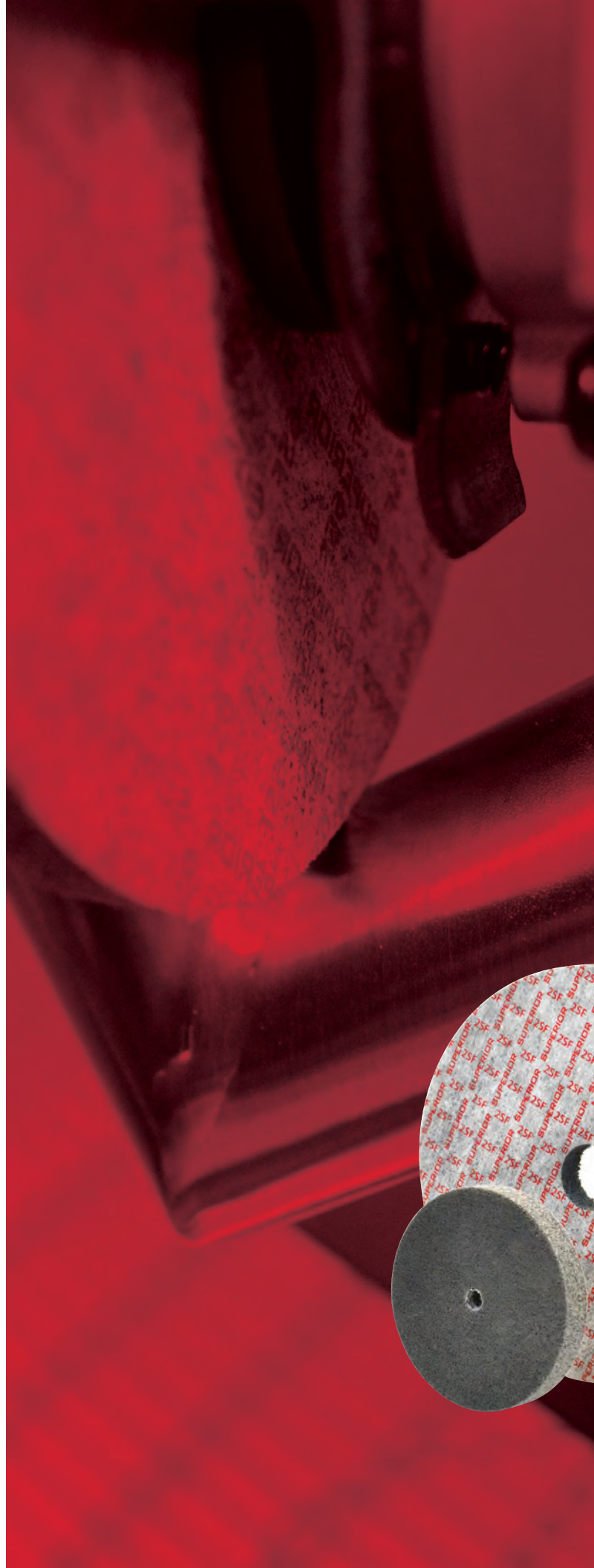



Layered sheets of nonwoven abrasives are compressed in resins, forming a dense slab, from which smaller diameter wheels are produced. The density of unitized wheels allows controlled cutting, cleaning and polishing action for tighter tolerances.

► Understanding Material Grades		
Wheel Density	Wheel density also translates to flexibility and conformity. Lower densities will not alter workpiece geometry, whereas higher densities will work and remove material faster.	<p>2 ————— 8</p> <p>Softer, more conformable                      Harder, more durable</p> <p>Masking/Finishing      Light Deburring/Cleaning/Finishing      Heavy Deburring</p>
Grain Type	Aluminum oxide grains are denser, allowing higher pressure, and recommended for softer ferrous or non-ferrous materials. Silicon carbide grains are harder and sharper, yet brittle and used with lighter pressure on harder materials, like stainless or titanium.	<p>A ————— S</p> <p>Durable, long lasting                      Sharper, finer scratch pattern</p> <p>Aluminum Oxide                                              Silicon Carbide</p>
Grain Size	The abrasive grain size used in each wheel controls the depth and refinement of the scratch. Due to the nonwoven construction, unitized products will usually finish 2-3 grits finer than the grain size.	<p>Coarse (60-80) ————— Medium (100-150) ————— Fine (180-220)</p> <p>Faster cut, rougher finish                      Reduced cut rate, finer finish</p>

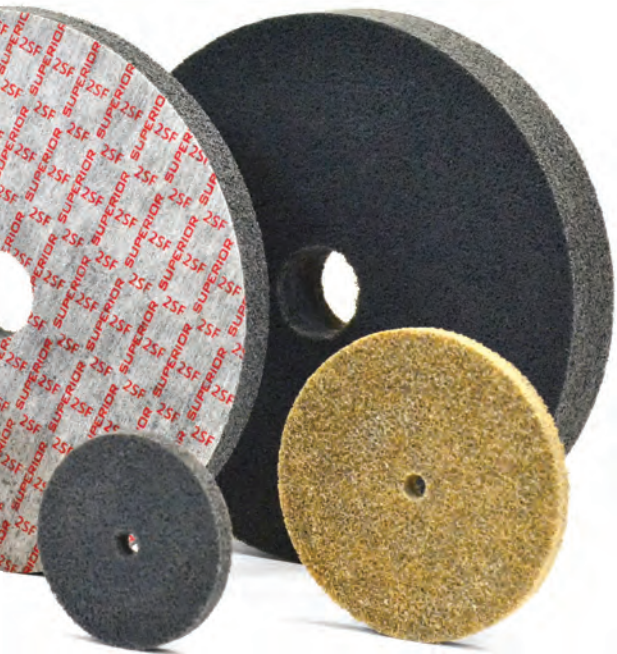

► Performance	2	4	6	8
Cut	○	○	◐	●
Life	○	○	◐	●
Finish	●	●	◐	○
Flexibility	●	●	◐	○
Pressure	○	○	◐	●
Density	○	○	◐	●

● Best   ◐ Better   ○ Good

# SHUR-BRITE® Unitized

## SHANK MOUNTED UNITIZED WHEELS

Reach small and intricate areas to safely deburr, clean or polish without damaging parts. Compressed nonwoven material will conform to contours and acute angles and not alter part geometry.

- ▶ Easily navigate intricate parts
- ▶ Light deburring in narrow areas
- ▶ Clean or finish small, TIG welded parts or seams
- ▶ No mandrels or adapters required



Diameter	Thickness	Shank	Max RPM by Density		Optimal RPM	Std. Pkg.	2SF	4SF	6AM	8AC
			2	4-8						
1"	1/8"	1/8"	30,100	35,100	10,500	10	<b>54697</b>	<b>54826</b>	<b>54698</b>	<b>54699</b>
1"	1/4"	1/8"	30,100	35,100	10,500	10	<b>54700</b>	<b>54785</b>	<b>54701</b>	<b>54702</b>
1-1/2"	1/4"	1/4"	30,100	35,100	7,200	10	<b>54703</b>	<b>54835</b>	<b>54704</b>	<b>54705</b>
2"	1/4"	1/4"	16,100	22,100	6,400	10	<b>54710</b>	<b>54831</b>	<b>54714</b>	<b>54716</b>
3"	1/4"	1/4"	15,100	18,100	6,400	10	<b>54718</b>	<b>54829</b>	<b>54725</b>	<b>54727</b>

● Ferrous ● Non-Ferrous ● Stainless ● Exotic Alloys ● Plastics ○ Composites

## ARBOR MOUNTED UNITIZED WHEELS

Conforming structure cuts consistently throughout wheel life without heat buildup, extending life on soft and exotic alloys. Nonwoven structure will not disrupt critical part tolerances while cleaning or removing residue, finishing or polishing.

- ▶ Consistent cut life and heat tolerance
- ▶ Finish turbine blades and aerospace parts
- ▶ Remove machining marks or process traces

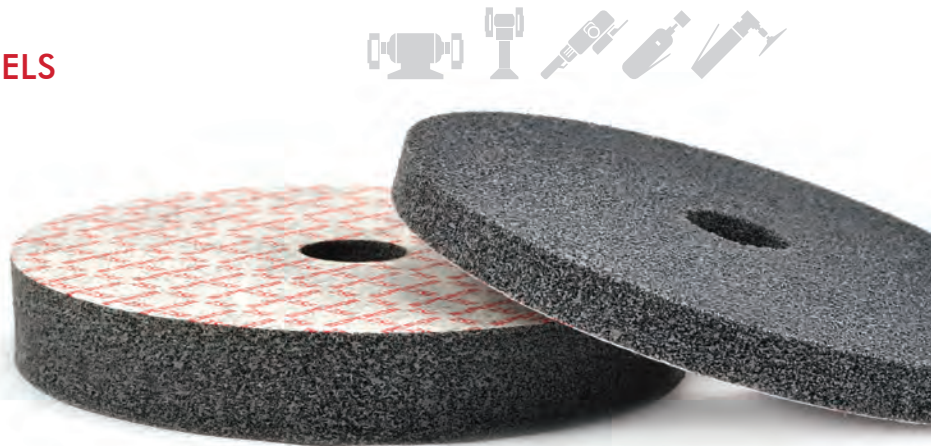

Diameter	Thickness	Arbor	Max RPM by Density		Optimal RPM	Std. Pkg.	2SF	2AM	4SF	6SF	6AM	8AM	8AC
			2	4-8									
1"	1/8"	1/8"	30,100	35,100	10,500	10	<b>54652</b>	-	<b>54825</b>	-	<b>54653</b>	-	<b>54654</b>
1"	1/4"	1/8"	30,100	35,100	10,500	10	<b>54655</b>	-	<b>54784</b>	-	<b>54656</b>	-	<b>54657</b>
1"	1"	3/16"	35,100		10,500	10	-	-	-	<b>54658</b>	<b>54659</b>	-	<b>54660</b>
1-1/2"	1/4"	1/4"	20,100	30,100	7,200	10	<b>54661</b>	-	<b>54836</b>	-	<b>54662</b>	-	<b>54663</b>
2"	1/4"	1/4"	16,100	22,100	6,400	10	<b>54664</b>	-	<b>54832</b>	-	<b>54665</b>	-	<b>54666</b>
3"	1/4"	1/4"	15,100	18,100	6,400	10	<b>54667</b>	<b>54668</b>	<b>54830</b>	-	<b>54670</b>	<b>54669</b>	<b>54671</b>
3"	1/2"	1/4"	15,100	18,100	6,400	10	<b>54672</b>	-	-	-	<b>54673</b>	-	-
4"	1/4"	1/4"	8,500		4,800	10	<b>54674</b>	-	-	-	-	-	-
6"	1/2"	1"	5,000		3,200	4	<b>54675</b>	-	-	-	-	-	-
6"	1"	1"	5,000		3,200	2	<b>54676</b>	-	-	-	-	-	-

● Ferrous ● Non-Ferrous ● Stainless ● Exotic Alloys ● Plastics ○ Composites

## QUICK CHANGE UNITIZED DISCS

Quick change button allows fast changeover between grades and applies additional pressure and support. Non-directional structure allows discs to be used flat or on edge, for multiple contours or part geometries.

- ▶ Finish contoured orthoses and surgical devices
- ▶ Small parts deburring or flash removal
- ▶ Remove overspray or adhesives without damage
- ▶ Finish aerospace parts and turbine blades



Type	Diameter	Thickness	Max RPM by Density		Optimal RPM	Std. Pkg.	2SF	4SF	6AM	8AC
			2	4-8						
Type R	2"	1/4"	16,100	22,100	9,500	10	<b>54709</b>	<b>54872</b>	<b>54713</b>	<b>54715</b>
	3"	1/4"	15,100	18,100	6,400	10	<b>54717</b>	<b>54873</b>	<b>54723</b>	<b>54726</b>

● Ferrous ● Non-Ferrous ● Stainless ● Exotic Alloys ● Plastics ○ Composites



# SHUR-BRITE® Unitized

## FINAL POLISHING UNITIZED WHEELS

A soft density and very fine abrasive grain are used to produce a high luster on stainless steel and mirror finishes on a variety of metals. Able to conform easily, multiple shapes and contours can be finished or polished to final requirements.

- ▶ Soft density will not alter surface tolerances
- ▶ Easily conforms to multiple dimensions
- ▶ Very fine grains produce sharp, reflective cuts
- ▶ Can be used with compounds for fine polishing



Diameter	Thickness	Arbor	Max RPM	Optimal RPM	Std. Pkg.	2SVF
1"	1"	3/16"	30,100	10,500	10	<b>45102</b>
2"	1/4"	1/4"	16,100	6,400	10	45103
2"	1/2"	1/4"	15,100	6,400	10	45104
3"	1/4"	1/4"	15,100	6,400	10	<b>45105</b>
3"	1/2"	1/4"	15,100	6,400	10	45106

● Ferrous ● Non-Ferrous ● Stainless ○ Exotic Alloys ○ Plastics ○ Composites

### ▶ Superior Support

Use 1" x 1" plug wheels with Quick Change Wheel Mandrels (p.69).



## QUICK CHANGE FINAL POLISHING DISCS

Specifically designed to polish smaller surface areas, quick change button allows fast changeover and applies additional pressure and support with rubber backing pad. Discs can be used flat or on edge, for multiple contours or part geometries.

- ▶ Will not alter part geometry or critical tolerances
- ▶ Small parts finishing and polishing
- ▶ Easily controllable operation and applied finesse
- ▶ Blend, finish or polish small spot welds with surrounding surface



Type	Diameter	Thickness	Max RPM	Optimal RPM	Std. Pkg.	2SVF
Type R	2"	1/4"	16,100	9,500	10	<b>45618</b>
	3"	1/4"	15,100	6,400	10	<b>45620</b>

● Ferrous ● Non-Ferrous ● Stainless ○ Exotic Alloys ○ Plastics ○ Composites

## DEPRESSED CENTER FINAL POLISHING DISCS

Quickly produce a high luster or mirror finish with a greater wheel contact area. For use on large, flat surfaces or subtle contours with controlled pressure from fiberglass reinforced backing plate.

- ▶ Reinforced leverage with cushioned control
- ▶ Finish larger areas without operator or tooling fatigue
- ▶ Contour large inner or outer diameters

### ▶ Superior Support

Unitized products are run significantly slower than their coated counterparts. The use of variable speed grinders optimizes performance. For optimum polishing, try cutting RPM in half.

Diameter	Arbor	Max RPM	Optimal RPM	Std. Pkg.	4SVF
4-1/2"	7/8"	11,000	6,000	1	<b>45107</b>

Ferrous
  Non-Ferrous
  Stainless
  Exotic Alloys
  Plastics
  Composites



# SHUR-BRITE® Unitized

## SCREW LOCK TYPE WHEEL ADAPTERS

Easy to access slotted screw secures wheel in place, providing a reduced adapter profile. Available in various lengths, with shank diameters from 1/8" to 3/8" for multiple tools.

- ▶ Easy product changeover with basic tools
- ▶ Available for a variety of wheel dimensions
- ▶ Long lasting, rust proof finish



### ▶ Superior Support

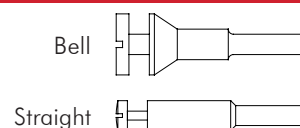

Wheel Arbor Hole	Wheel Thickness	Shank Diameter	Head Style	Head Diameter	Overall Length	Max RPM	Std. Pkg.	Part #
1/4"	Up to 1/4"	1/4"	Bell	3/4"	2"	28,000	1	<b>12213</b>
3/8"	Up to 1/4"	1/4"	Bell	3/4"	2"	28,000	1	<b>12214</b>
1/4" or 3/8"	Up to 1/4"	1/4"	Bell	3/4"	2"	28,000	1	<b>26222</b>
1/4"	Up to 1/2"	1/4"	Bell	3/4"	2-1/2"	28,000	1	<b>35733</b>
1/4"	Up to 1"	1/4"	Bell	3/4"	2-1/2"	28,000	1	35734
1/16"	Up to 1/4"	1/8"	Straight	3/16"	1-3/4"	28,000	1	<b>12220</b>
1/8"	Up to 3/16"	1/8"	Straight	1/4"	1-1/2"	28,000	1	<b>12221</b>
1/8"	Up to 1/4"	1/4"	Straight	3/8"	2"	28,000	1	<b>12222</b>
1/4"	Up to 1/4"	1/4"	Straight	7/16"	2"	28,000	1	<b>12223</b>
1/8"	Up to 1/4"	1/4"	Straight	3/8"	3"	28,000	1	<b>12224</b>
1/4"	Up to 1/4"	1/4"	Straight	7/16"	3"	28,000	1	<b>12225</b>

## CHUCK TYPE WHEEL MANDRELS

Available for both 1/4" or 3/8" arbor holes and up to 3/8" wheel thickness. Washer and slotted screw secure wheels firmly in place.

- ▶ Remove washer and wheel with basic tools
- ▶ Long lasting, rust proof finish



Wheel Arbor Hole	Wheel Thickness	Shank Diameter	Flange Diameter	Overall Length	Max RPM	Std. Pkg.	Part #
1/4"	1/4" to 3/8"	1/4"	9/16"	2-1/8"	28,000	1	<b>12211</b>
3/8"	1/4" to 3/8"	1/4"	11/16"	2-1/8"	28,000	1	<b>12212</b>

## NUT LOCK WHEEL ADAPTERS

Recommended for wheels used on edge. Large washer provides additional stability on larger diameter wheels. Fits wheels up to 3/4" thick.

- ▶ Remove wheel with basic wrench
- ▶ Machine flanged washer for extra stability



Wheel Arbor Hole	Wheel Thickness	Shank Diameter	Washer Diameter	Overall Length	Max RPM	Std. Pkg.	Part #
1/4"	Up to 5/8"	1/4"	1"	2-1/2"	28,000	1	<b>10540</b>
3/8"	Up to 3/4"	1/4"	1"	2-1/2"	28,000	1	<b>12215</b>

## QUICK CHANGE WHEEL MANDRELS

Quick changeover, screw in mandrel for plug wheels. Coarse threads secure wheel in place without additional tooling.

- ▶ Quick changeover without tooling
- ▶ Rust proof, black oxide finish



Wheel Arbor Hole	Wheel Thickness	Shank Diameter	Shoulder Diameter	Overall Length	Max RPM	Std. Pkg.	Part #
3/16"	1"	1/4"	1/2"	1-3/4"	28,000	1	<b>37519</b>

## ARBOR REDUCER BUSHINGS

Retrofit existing tooling to accept wheels with 1" arbor.



Arbor Diameter	Reduced Diameter	Std. Pkg.	Part #
1"	3/4"	1 Pair	10391
1"	5/8"	1 Pair	<b>10392</b>
1"	1/2"	1 Pair	<b>10393</b>

## QUICK CHANGE DISC HOLDERS

Quick change rubber backing pad provides stability and flexibility under directional pressure.



Type	Diameter	Shank	Max RPM	Std. Pkg.	Part #
Type R	2"	1/4"	30,000	1	<b>11275</b>
	3"	1/4"	20,000	1	<b>11276</b>

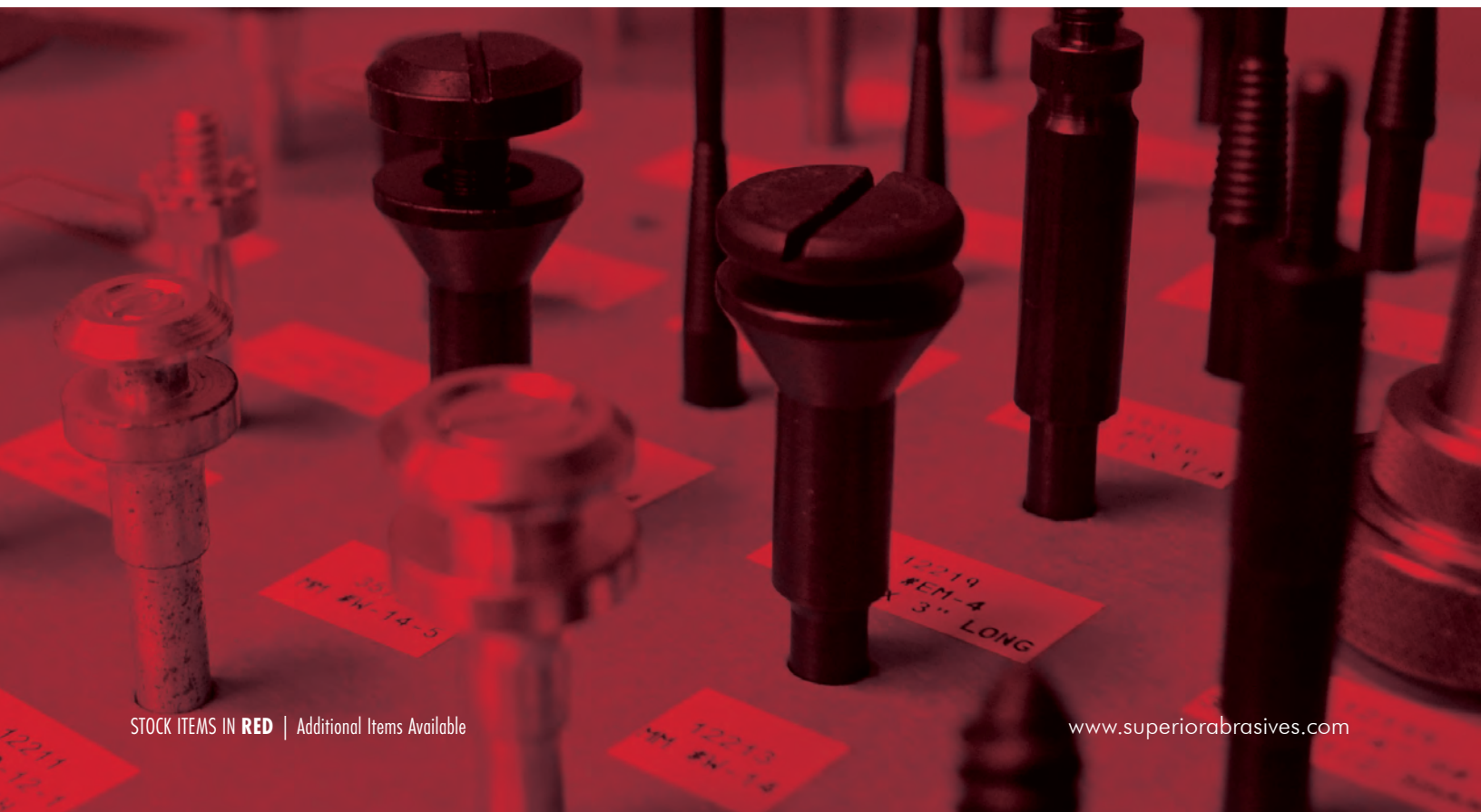







# SHUR-BRITE<sup>®</sup> Stripping

# SHUR-BRITE®

## Stripping Characteristics

Similar in components to other nonwoven abrasives, SHUR-BRITE® Stripping materials are made with larger nylon fibers and increased resin content to produce a firm structure. The resin remains flexible, but the nylon fibers are thickly surrounded to hold their structure in place.

Extra coarse silicon carbide grains provide aggressive cutting action, but the friability of the grains prevents unnecessary gouging and metal removal. The balance of rigidity and flexibility allow the sharp grains to penetrate and remove the outermost layers without cutting deep into the solid surface.

## Stripping Features

Stripping products are aggressive enough to quickly remove layers of paint, residue, corrosion or rust, but the flexibility will not alter or reshape the solid surface underneath. The open, nonwoven structure resists heat buildup, which could cause excessive loading of some surface layers. Stripping products can be used on all sides and offer consistent performance throughout life.

- ▶ Removes only formed or applied layers
- ▶ Will not gouge metallic surfaces
- ▶ Greater surface area than wire brushes
- ▶ Stiff, open structure resists clogging and loading
- ▶ Consistent performance throughout life

## Applications

- ▶ Remove gasket or adhesive residue
- ▶ Maintenance and machine refurbishing
- ▶ Clean welds or seams without removing material
- ▶ Removal of paint and other clogging materials
- ▶ Surface corrosion and rust removal

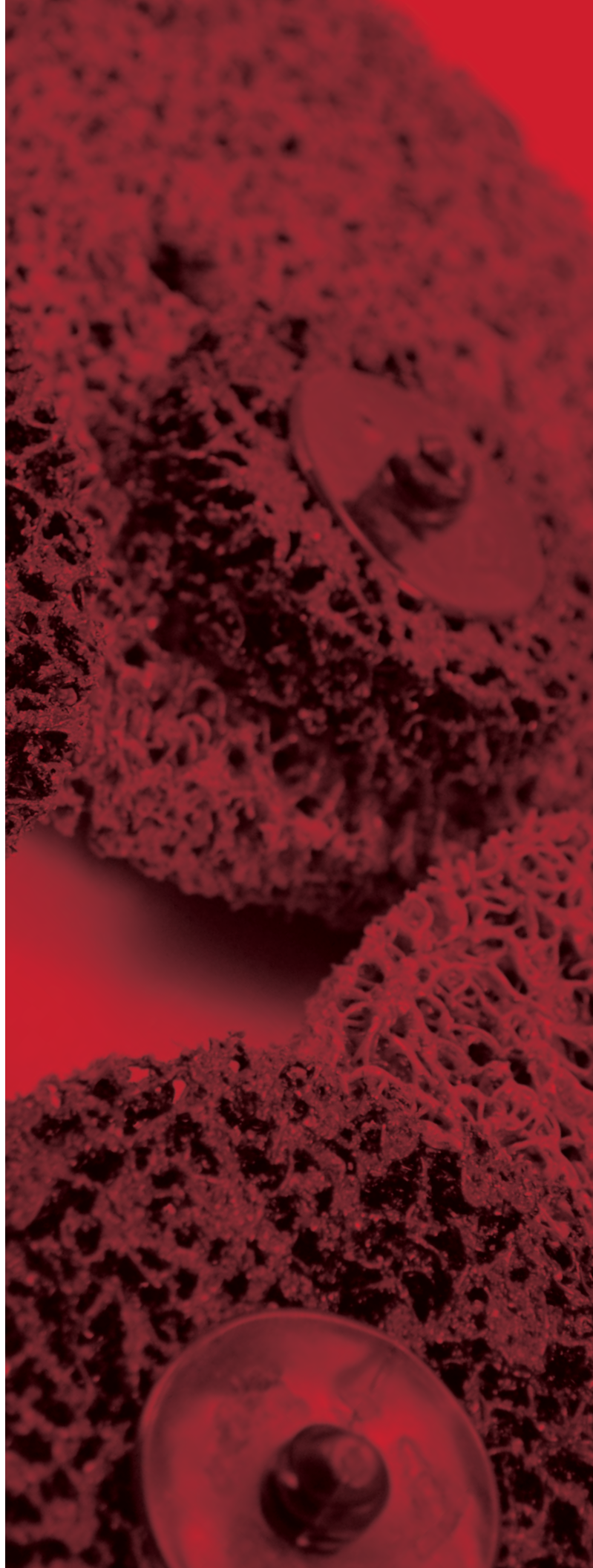

Less compressed, yet harder and richer with resins, stripping products remove workpiece layers of the least resistance. The extremely open, less-conformable structure is ideal for fast removal of undesired coatings.

Most Aggressive

<span style="font-size: 2em; font-weight: bold;">R<sub>D</sub></span>	<span style="font-size: 1.5em; font-weight: bold;">Red</span>	A higher resin content decreases flexibility for a more aggressive cutting action.
		<ul style="list-style-type: none"> <li>Heavy duty removal</li> <li>Extended life and consistent performance</li> <li>Reduced heat buildup and loading</li> </ul>
<span style="font-size: 2em; font-weight: bold;">B<sub>L</sub></span>	<span style="font-size: 1.5em; font-weight: bold;">Black</span>	Slightly flexible and conformable, reducing chances of marring or gouging softer metals.
		<ul style="list-style-type: none"> <li>Consistent performance throughout life</li> <li>Open structure reduces loading and clogging</li> </ul>

Least Aggressive

▶ Performance	Red	Black
Cut	●	◐
Life	●	◐
Finish	◐	●
Flexibility	◐	●
Pressure	●	◐
Density	●	◐

● Best ◐ Better ○ Good

## SHUR-BRITE® Stripping

### **R<sub>D</sub>** ARBOR MOUNTED RED STRIPPING WHEELS

Aggressive removal of surface layers and contaminants. Extended wheel life and consistent cutting action. Can be stacked on stationary spindles to increase surface coverage and removal rate.

- ▶ Anti-clogging structure
- ▶ Quickly remove powder coatings
- ▶ Consistent, extended cutting action

Diameter	Thickness	Arbor	Max RPM	Optimal RPM	Std. Pkg.	XCRS
4"	1/2"	1/2"	8,000	4,500	10	<b>54897</b>
6"	1/2"	1/2"	5,500	3,000	10	<b>54898</b>

● Ferrous   ● Non-Ferrous   ● Stainless   ● Exotic Alloys   ○ Plastics   ○ Composites



### **B<sub>L</sub>** ARBOR MOUNTED BLACK STRIPPING WHEELS

Consistent removal of rust, paint or surface contaminants. Clean weld discoloration without altering workpiece. Moderate flexibility reduces harm to softer materials.

- ▶ Open structure resists heat
- ▶ Paint removal without gouging
- ▶ Gasket or adhesive removal without clogging

Diameter	Thickness	Arbor	Max RPM	Optimal RPM	Std. Pkg.	XCRS
4"	1/2"	1/4"	8,000	4,500	10	<b>38699</b>
4"	1/2"	1/2"	8,000	4,500	10	<b>34361</b>
6"	1/2"	1/2"	5,500	3,000	10	<b>34362</b>
8"	1/2"	1/2"	4,000	2,000	10	<b>34363</b>

● Ferrous   ● Non-Ferrous   ● Stainless   ● Exotic Alloys   ○ Plastics   ○ Composites



### NUT LOCK WHEEL ADAPTERS

Wheel Arbor Hole	Wheel Thickness	Shank Diameter	Washer Diameter	Overall Length	Max RPM	Std. Pkg.	Part #
1/4"	Up to 5/8"	1/4"	1"	2-1/2"	28,000	1	<b>10540</b>
1/2"	Up to 1/2"	1/4"	1-3/4"	2-1/2"	28,000	1	<b>12216</b>



## BL SHANK MOUNTED BLACK STRIPPING WHEELS



Utilize die grinders to navigate intricate parts or access small areas. Clean or prep stationary parts or extruded channels. No accessories necessary.

- ▶ Easily reach narrow areas
- ▶ Navigate and finesse small diameters and inner contours
- ▶ No mandrels or additional adapters required



Diameter	Width	Shank	Max RPM	Optimal RPM	Std. Pkg.	XCRS
2"	1/2"	1/4"	16,000	6,500	10	<b>35805</b>
2"	1"	1/4"	16,000	6,500	10	<b>35806</b>
3"	1/2"	1/4"	10,500	4,500	10	<b>34359</b>
3"	1"	1/4"	10,500	4,500	10	<b>34360</b>
4"	1/2"	1/4"	8,000	3,500	10	<b>38446</b>
4"	1"	1/4"	8,000	3,500	10	<b>38447</b>

Ferrous  
  Non-Ferrous  
  Stainless  
  Exotic Alloys  
  Plastics  
  Composites





## **R<sub>D</sub>** DEPRESSED CENTER RED STRIPPING DISCS

Fiberglass reinforced backing plate allows increased pressure for harder surface coatings. Quickly clean or prep large areas without clogging or loading. Extended product life reduces changeover frequency.

- ▶ Used on large, flat or contoured surfaces
- ▶ Efficiently strip paint or coatings from large machinery
- ▶ Easily remove epoxies or other tough coatings

Diameter	Arbor	Max RPM	Optimal RPM	Std. Pkg.	XCRS
4-1/2"	7/8"	11,000	8,600	10	<b>54896</b>
5"	7/8"	9,800	7,800	10	<b>55061</b>

- Ferrous   ● Non-Ferrous   ● Stainless   ● Exotic Alloys   ○ Plastics   ○ Composites



## **B<sub>L</sub>** DEPRESSED CENTER BLACK STRIPPING DISCS

Reinforced backing provides added leverage on flat or contoured parts. Open structure resists heat, loading and clogging, prolonging product life.

- ▶ Increased area and surface coverage
- ▶ Large-scale removal on hard surfaces
- ▶ Consistent performance throughout life

Diameter	Arbor	Max RPM	Optimal RPM	Std. Pkg.	XCRS
4-1/2"	7/8"	11,000	8,600	10	<b>34366</b>

- Ferrous   ● Non-Ferrous   ● Stainless   ● Exotic Alloys   ○ Plastics   ○ Composites



## RD QUICK CHANGE RED STRIPPING DISCS

Small diameter discs used flat or on edge, reaching small areas or intricate shapes. Quick change function reduces changeover time and can easily switch between other quick change products for multi-step processing.

- ▶ Easy control in small areas and on contours
- ▶ Consistent, long-life cutting action
- ▶ Aggressive cutting action for tough coatings
- ▶ Switch between quick change products



Type	Diameter	Max RPM	Optimal RPM	Std. Pkg.	XCRS
Type R	2"	10,500	8,000	50	<b>54899</b>
	3"	7,000	5,600	25	<b>54900</b>

● Ferrous   ● Non-Ferrous   ● Stainless   ● Exotic Alloys   ○ Plastics   ○ Composites

## BL QUICK CHANGE BLACK STRIPPING DISCS



Ideal for spot removal, cleaning seam lines, or contoured stripping in small areas or intricate parts. Easily transition to other quick change applications.

- ▶ Gasket and residue removal before reassembly
- ▶ Easily access small areas
- ▶ Consistent cutting action throughout life

Type	Diameter	Max RPM	Optimal RPM	Std. Pkg.	XCRS
Type R	2"	10,500	8,000	50	<b>34364</b>
	3"	7,000	5,600	25	<b>34365</b>
	4"	9,800	7,800	10	41334

● Ferrous   ● Non-Ferrous   ● Stainless   ● Exotic Alloys   ○ Plastics   ○ Composites

### ▶ Superior Support

Stripping products are more conformable and safer than wire brushes, which can shed wires.

## QUICK CHANGE DISC HOLDERS

Type	Diameter	Shank	Max RPM	Std. Pkg.	Part #
Type R	2"	1/4"	30,000	1	<b>11275</b>
	3"	1/4"	20,000	1	<b>11276</b>
	4"	1/4"	10,000	1	<b>34992</b>

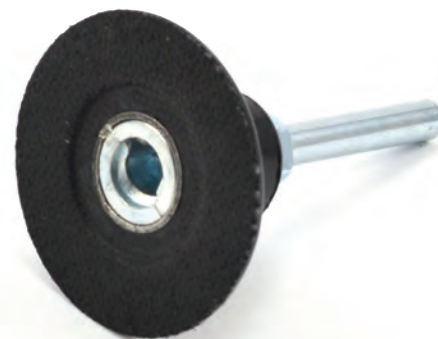







# SHUR-KUT<sup>®</sup> Coated Abrasives

## Coated Features

From shaping and heavy material removal to surface preparation and fine finishing, the broad selection of SHUR-KUT® Coated Abrasives includes several specialized materials and product forms. Variability in backing weight and flexibility, grain structure and additional coatings allow choice material combinations per your specific application, providing the most efficient solution.

## Coated Characteristics

Although considered a 'single-layered' structure due to its one-directional operation, coated abrasives consist of resin bonding agents and abrasive grains layered and adhered to a supportive backing. The structure of coated abrasive materials offers more aggressive cutting action, simply considering the lack of compression and conformability to surfaces.

The dense organization of abrasive grains provides more friction, which results in cutting power, but also creates more heat. To combat excessive heat, proper grain selection is made based on metal type. Harder metals require a sharper grain to penetrate and cut, versus softer metals that are easily worn away. The addition of a grinding aid or stearate acts as a friction reducer, resulting in more efficient cutting action.

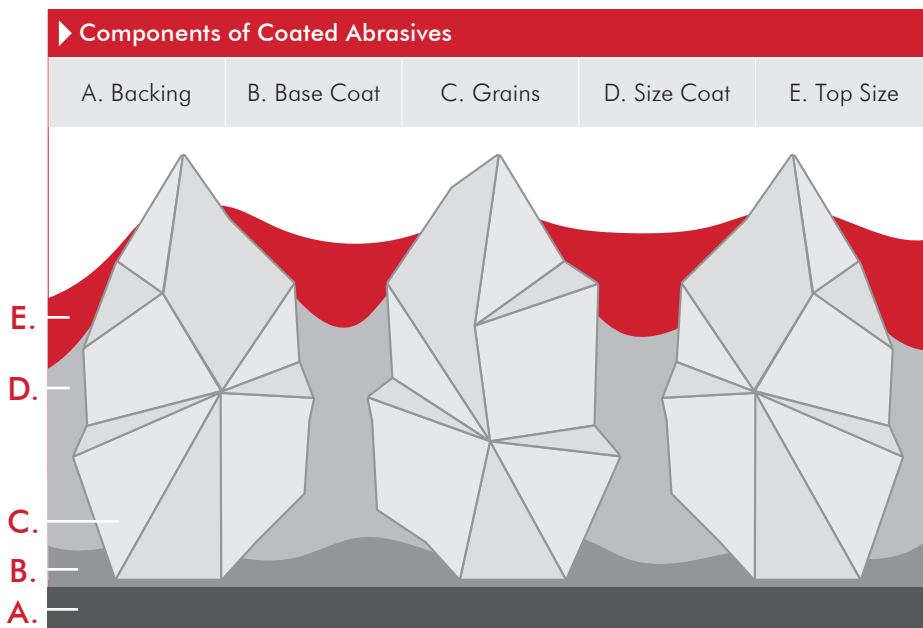

## Backing Materials

Various backings help determine material strength, durability and flexibility – All critical factors when considering particular applications. Cloth backings consist of either cotton, which is most popular, or a more performance-oriented polyester, which provides better grain retention. Cotton backings are classified by flexibility, versus the weight of paper backings.

▶ Backing Types												
Weight	Paper						Cloth					
	A	B	C	D	E	F	E	F	J	T	X	Y
Durability												
Thickness												
Flexibility												

## Base & Size Coat

The manner in which abrasive grains are adhered to the backing is done with a base coat. Grains are set in a resin or glue that secures grains upright and in place. On top of the grains and base coat, another layer of resin is applied, creating the size coat. Various alterations to resin compounds allow more or less flexibility of the abrasive grains, sometimes creating a stiffer, more durable product.

## Top Size Coat

To counteract friction, excessive heat or loading, an additional layer may be added to coated abrasives. Top size coats can be utilized as a grinding aid or a stearate, which is commonly seen on products with paper backings.

Top size grinding aids react to high heat caused by friction from harder metals and alloys. Necessary pressure can be applied, but heat is not generated as quickly, reducing the stress and premature wear of the abrasive grains.

In lower temperature operations, a top size stearate may be preferred. Calcium stearate acts as a lubricant that reduces loading and clogging of softer metals with a lower melting point.

### Abrasive Grains

Each unique group of abrasive grains share similar qualities tailored toward specific applications and operations. Some factors to consider when choosing abrasive grains are cut rate, finish quality, production environment and cost, as applied to any particular surface or workpiece.

 <p><b>C<sup>A</sup></b> Ceramic Alumina</p>	<p>Tough, sharp grain fractures under moderate pressure to continually reveal fresh cutting points for consistent, long-lasting performance.</p>
 <p><b>S<sub>c</sub></b> Silicon Carbide</p>	<p>Hard, extremely sharp grain breaks away under light pressure to continually expose fine cutting edges.</p>
 <p><b>Z<sub>A</sub></b> Zirconia Alumina</p>	<p>Long-lasting, dense grain produces new cutting points under high pressure and aggressive use.</p>
 <p><b>A<sup>O</sup></b> Aluminum Oxide</p>	<p>Dense and durable, multi-purpose grain for general grinding on all metals. Grains dull as they are worn, reducing consistency throughout use.</p>

Our comprehensive line of SHUR-KUT® products provides efficient solutions for heavy grinding and stock removal to finishing and fine polishing.

Discs .....	84
Belts .....	108
Wheels .....	112
Bore Polishers .....	118
Cartridge Rolls .....	120
Caps .....	126
Cones .....	130
Bands .....	132
Pads .....	135
Rolls .....	136
Sheets .....	138

# SHUR-KUT® Coated

## Quick Change Discs

The reduced diameter of quick change discs provide ease of use on intricate parts, and excellent control when shaping or blending surface portions. Ideally used on flat surfaces to utilize more cutting action, the moderate flexibility of quick change discs and their holders also allow contouring and access to inner corners. The unique quick change functionality reduces changeover downtime and eases transitions between grit, material, or even abrasive type where multi-step processes are required.

## Applications

- ▶ General purpose grinding and stock removal
- ▶ Deburring or parting line removal on cast parts
- ▶ Spot weld removal and blending
- ▶ Mold and cavity grinding and refurbishing
- ▶ Grinding and preparing hot castings



# Quick Change Discs

## CA CERAMIC PREMIUM QUICK CHANGE DISCS



Premium, self-sharpening grain with advanced grinding aid substantially reduces heat to increase cutting power on harder metals. Durable polyester backing and cooler cutting action extend product life on lighter pressure applications.

- ▶ Light pressure, high temperature applications
- ▶ Aggressive cut rate on hard or exotic alloys
- ▶ Reduced operator and product fatigue
- ▶ Higher, prolonged cut rate



Type	Diameter	Max RPM	Optimal RPM	Std. Pkg.	36	60	80	120
Type S	2"	30,000	10,500	100	<b>54559</b>	<b>54124</b>	<b>54561</b>	<b>54562</b>
	3"	20,000	7,000	50	<b>54563</b>	<b>54125</b>	<b>54564</b>	<b>54565</b>
Type R	2"	30,000	10,500	100	<b>54566</b>	<b>54503</b>	<b>54509</b>	<b>54504</b>
	3"	20,000	7,000	50	<b>54567</b>	<b>54505</b>	<b>54510</b>	<b>54506</b>

● Ferrous ● Non-Ferrous ● Stainless ● Exotic Alloys ○ Plastics ○ Composites

## CA CERAMIC ADVANTAGE QUICK CHANGE DISCS

Finer crystalline grain structure introduces more cutting points under medium pressure. Increased amount of smaller cutting points provides a finer finish and longer life.

- ▶ Continual exposure of fresh, sharp cutting points
- ▶ Top size coat reduces loading, glazing and dulling
- ▶ Ideal for medium pressure applications



Type	Diameter	Max RPM	Optimal RPM	Std. Pkg.	36	40	50	60	80	120
Type S	2"	30,000	10,500	100	<b>53824</b>	<b>53904</b>	<b>53905</b>	<b>53906</b>	<b>53907</b>	<b>53908</b>
	3"	20,000	7,000	50	<b>53914</b>	<b>53915</b>	<b>53916</b>	<b>53917</b>	<b>53918</b>	<b>53919</b>
Type R	2"	30,000	10,500	100	<b>53726</b>	<b>53899</b>	<b>53900</b>	<b>53758</b>	<b>53902</b>	<b>53876</b>
	3"	20,000	7,000	50	<b>53814</b>	<b>53910</b>	<b>53911</b>	<b>53834</b>	<b>53912</b>	<b>53913</b>

● Ferrous ● Non-Ferrous ● Stainless ● Exotic Alloys ○ Plastics ○ Composites

## SHUR-KUT® Coated

## CA CERAMIC GRINDING AID QUICK CHANGE DISCS

Self-sharpening grains continually produce fresh cutting points, reducing friction and prolonging cut rates under lighter pressure. Additional grinding aid further reduces heat, extending disc life.

- ▶ Additional heat dissipation for high temperature grinding
- ▶ Sharp grains easily cut through stainless steel and alloys
- ▶ Flexible X-weight backing
- ▶ Extended life and grain retention



Type	Diameter	Max RPM	Optimal RPM	Std. Pkg.	36	40	50	60	80	120
Type S	1-1/2"	30,000	13,000	100	40305	40306	40307	<b>40308</b>	40309	40310
	2"	30,000	10,500	100	40311	40312	<b>40313</b>	<b>40314</b>	<b>40315</b>	<b>40316</b>
	3"	20,000	7,000	50	<b>40317</b>	40318	<b>40319</b>	<b>40320</b>	<b>40321</b>	40322
Type R	1-1/2"	30,000	13,000	100	40323	49377	40325	40326	40327	40328
	2"	30,000	10,500	100	<b>40329</b>	<b>40330</b>	<b>40331</b>	<b>40332</b>	<b>40333</b>	<b>40334</b>
	3"	20,000	7,000	50	<b>40335</b>	<b>40336</b>	<b>40337</b>	<b>40338</b>	<b>40339</b>	<b>40340</b>

● Ferrous ● Non-Ferrous ● Stainless ● Exotic Alloys ○ Plastics ○ Composites



## Sc SILICON CARBIDE QUICK CHANGE DISCS

Hard, friable grain exposes sharp edges under light pressure. Contaminate free and safe for aerospace and food processing applications. Ideal for final processing or sanitary polishing applications.

- ▶ Sharper grains produce finer scratch patterns
- ▶ Cut and polish non-ferrous metals
- ▶ Approved use on aircraft components



Type	Diameter	Max RPM	Optimal RPM	Std. Pkg.	60	80	120
Type S	2"	30,000	10,500	100	18154	16980	18157
	3"	20,000	7,000	50	18059	18166	49395
Type R	2"	30,000	10,500	100	<b>18216</b>	<b>18217</b>	<b>32035</b>
	3"	20,000	7,000	50	49393	32033	18232

● Ferrous ● Non-Ferrous ● Stainless ● Exotic Alloys ● Plastics ○ Composites

### ▶ Superior Support

Silicon carbide is ideal for aerospace operations in which iron contamination from other abrasive grains is of concern.

## Zr ZIRCONIA GRINDING AID QUICK CHANGE DISCS

Long lasting, durable grains and sharp cutting action with additional grinding aid to reduce heat generation. Cooler cut reduces friction and premature breakdown of grains and backing.

- ▶ Extended stock removal with low heat generation
- ▶ Aggressive grinding on stainless steel
- ▶ Hybrid grain exposes fresh cutting edge during use

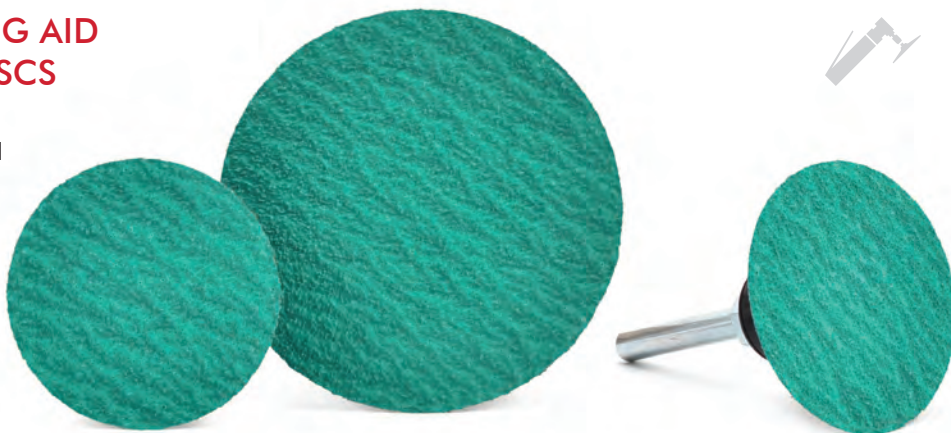

Type	Diameter	Max RPM	Optimal RPM	Std. Pkg.	36	40	50	60	80	120
Type S	1-1/2"	30,000	13,000	100	<b>36665</b>	36666	36667	<b>36668</b>	36669	36670
	2"	30,000	10,500	100	<b>36677</b>	<b>36678</b>	<b>36679</b>	<b>36680</b>	<b>36681</b>	<b>36682</b>
	3"	20,000	7,000	50	<b>36689</b>	36690	<b>36691</b>	<b>36692</b>	<b>36693</b>	<b>36694</b>
Type R	1-1/2"	30,000	13,000	100	<b>36671</b>	36672	36673	36674	36675	36676
	2"	30,000	10,500	100	<b>36683</b>	<b>36684</b>	<b>36685</b>	<b>36686</b>	<b>36687</b>	<b>36688</b>
	3"	20,000	7,000	50	<b>36695</b>	36696	<b>36697</b>	<b>36698</b>	<b>36699</b>	<b>36700</b>

● Ferrous ● Non-Ferrous ● Stainless ● Exotic Alloys ○ Plastics ● Composites

# SHUR-KUT® Coated

## Z ZIRCONIA A QUICK CHANGE DISCS

Dense grains continually generate new cutting edges, ideal for long lasting stock removal. Sharp grains reduce heat and friction in high pressure applications.

- ▶ Aggressive stock removal on hard metals and alloys
- ▶ Sharp cut reduces heat, friction and loading
- ▶ High pressure applications

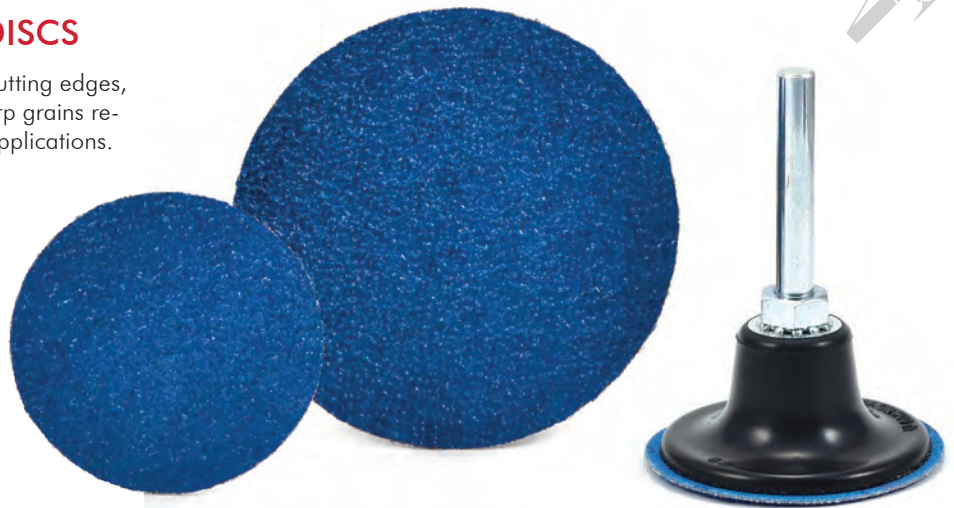

Type	Diameter	Max RPM	Optimal RPM	Std. Pkg.	36	40	50	60	80	120
Type S	2"	30,000	10,500	100	<b>11155</b>	11156	<b>11157</b>	<b>11158</b>	<b>11159</b>	<b>11161</b>
	3"	20,000	7,000	50	<b>11162</b>	11163	<b>11164</b>	<b>11165</b>	<b>11166</b>	<b>11168</b>
Type R	2"	30,000	10,500	100	<b>11258</b>	11259	<b>11260</b>	<b>11261</b>	<b>11262</b>	<b>11264</b>
	3"	20,000	7,000	50	<b>11265</b>	11266	11267	<b>11268</b>	<b>11269</b>	<b>11271</b>

● Ferrous ● Non-Ferrous ● Stainless ● Exotic Alloys ○ Plastics ● Composites

## A ALUMINUM OXIDE GRINDING AID O QUICK CHANGE DISCS

Reduced heat, general purpose grinding action on a variety of materials. Ideal for stock removal, shaping and deburring. Specially applied grinding aid reduces heat in aggressive, high pressure applications, extending cutting life.

- ▶ Additional heat dissipation non-ferrous metals
- ▶ Cool cutting action and extended life
- ▶ Efficient grinding and shaping on aircraft grade aluminum



Type	Diameter	Max RPM	Optimal RPM	Std. Pkg.	36	50	60	80	120
Type S	2"	30,000	10,500	100	<b>16827</b>	<b>16829</b>	<b>16830</b>	<b>16831</b>	<b>16833</b>
	3"	20,000	7,000	50	21344	26668	<b>22391</b>	<b>26825</b>	32018
Type R	2"	30,000	10,500	100	<b>32050</b>	<b>32049</b>	<b>32048</b>	<b>32047</b>	<b>32045</b>
	3"	20,000	7,000	50	<b>32044</b>	32043	32042	<b>32041</b>	<b>32039</b>

● Ferrous ● Non-Ferrous ○ Stainless ● Exotic Alloys ● Plastics ● Composites

## A<sup>o</sup> ALUMINUM OXIDE QUICK CHANGE DISCS

Dense, blocky grain well suited for general purpose grinding and stock removal. Durable use on ferrous, non-ferrous, stainless steels, alloys and non-metallics.

- ▶ General stock removal and shaping on most metals
- ▶ Spot weld removal or rough blending
- ▶ Leveling or blending imperfections



Type	Diameter	Max RPM	Optimal RPM	Std. Pkg.	24	36	40	50	60	80	100	120	150	180	240	320
Type S	1"	40,000	20,000	100	54308	<b>11087</b>	11088	11089	<b>11090</b>	<b>11091</b>	<b>11092</b>	<b>11093</b>	50911	11095	11096	11097
	1-1/2"	30,000	13,000	100	11098	<b>11099</b>	<b>11100</b>	<b>11101</b>	<b>11102</b>	<b>11103</b>	<b>11104</b>	<b>11105</b>	11106	<b>11107</b>	<b>11108</b>	11109
	2"	30,000	10,500	100	<b>11110</b>	<b>11111</b>	<b>11112</b>	<b>11113</b>	<b>11114</b>	<b>11115</b>	<b>11116</b>	<b>11117</b>	<b>11118</b>	<b>11119</b>	<b>11120</b>	<b>11121</b>
	3"	20,000	7,000	50	<b>11122</b>	<b>11123</b>	<b>11124</b>	<b>11125</b>	<b>11126</b>	<b>11127</b>	<b>11128</b>	<b>11129</b>	<b>11130</b>	<b>11131</b>	<b>11132</b>	<b>11133</b>
Type R	1"	40,000	20,000	100	-	<b>35361</b>	42716	34998	<b>11193</b>	<b>11194</b>	38037	<b>11196</b>	-	11198	11199	39121
	1-1/2"	30,000	13,000	100	11201	<b>11202</b>	11203	<b>11204</b>	<b>11205</b>	<b>11206</b>	11207	<b>11208</b>	43491	<b>11210</b>	11211	33983
	2"	30,000	10,500	100	<b>11213</b>	<b>11214</b>	<b>11215</b>	<b>11216</b>	<b>11217</b>	<b>11218</b>	<b>11219</b>	<b>11220</b>	<b>34463</b>	<b>11222</b>	<b>11223</b>	<b>11224</b>
	3"	20,000	7,000	50	<b>11225</b>	<b>11226</b>	<b>11227</b>	<b>11228</b>	<b>11229</b>	<b>11230</b>	<b>11231</b>	<b>11232</b>	<b>11233</b>	<b>11234</b>	<b>11235</b>	<b>11236</b>

● Ferrous ● Non-Ferrous ○ Stainless ○ Exotic Alloys ● Plastics ● Composites



## A<sup>o</sup> ALUMINUM OXIDE COMPACT GRAIN QUICK CHANGE DISCS

Clusters of aluminum oxide grains wear away to reveal fresh grains to maintain cutting rate and consistency, substantially extending disc life. Ideal for consistent surface finishes and stock removal rates.

- ▶ Consistent performance and extended wear rate
- ▶ Moderate pressure to evenly break down grain clusters
- ▶ Consistently polishing multiple heat sensitive parts

Type	Diameter	Max RPM	Optimal RPM	Std. Pkg.	80	120	180	240	320
Type S	2"	30,000	10,500	100	<b>40270</b>	<b>40271</b>	40272	40273	40274
	3"	20,000	7,000	50	40277	<b>40278</b>	40279	40280	40281
Type R	2"	30,000	10,500	100	<b>40291</b>	<b>40292</b>	40293	40294	40295
	3"	20,000	7,000	50	<b>40298</b>	40299	<b>40300</b>	40301	40302

● Ferrous ● Non-Ferrous ○ Stainless ○ Exotic Alloys ○ Plastics ● Composites

# SHUR-KUT® Coated

## CA RIGID KUT CERAMIC QUICK CHANGE DISCS

Specialized backing for aggressive grinding and high-pressure applications on hard alloys and other metals. Rigid backing and improved grain retention transfer more pressure to properly breakdown ceramic grains, exposing new, sharp cutting edges.

- ▶ Self-sharpening grains permit cooler cut
- ▶ Better edge wear than fiber backings
- ▶ Apply higher pressure than standard backings



Type	Diameter	Max RPM	Optimal RPM	Std. Pkg.	36	50	60	80	100	120
Type S	2"	30,000	10,500	100	47801	<b>47802</b>	<b>47803</b>	47804	47805	47806
	3"	20,000	7,000	50	47807	47808	47809	47810	47811	47812
Type R	2"	30,000	10,500	100	<b>47813</b>	<b>47814</b>	<b>47815</b>	47816	47817	47818
	3"	20,000	7,000	50	<b>47819</b>	47820	<b>47821</b>	<b>47822</b>	47823	47824

● Ferrous ● Non-Ferrous ● Stainless ● Exotic Alloys ● Plastics ● Composites

## AO RIGID KUT ALUMINUM OXIDE QUICK CHANGE DISCS

Stiff backing keeps grains in place during aggressive, general purpose applications. High edge retention resists shredding during sharp deburring applications. Dense aluminum oxide grains suitable for most metals and general applications.

- ▶ Dense grains ideal for stock removal
- ▶ Highly resistant to shredding
- ▶ Heavy deburring and edge applications



Type	Diameter	Max RPM	Optimal RPM	Std. Pkg.	36	50	60	80	100	120
Type S	2"	30,000	10,500	100	46853	46854	46855	46856	<b>46857</b>	46858
	3"	20,000	7,000	50	46859	46860	46861	46862	46863	46864
Type R	2"	30,000	10,500	100	<b>46871</b>	46872	46873	46874	46875	<b>46876</b>
	3"	20,000	7,000	50	46877	46878	<b>46879</b>	46880	46881	46882

● Ferrous ● Non-Ferrous ○ Stainless ● Exotic Alloys ● Plastics ● Composites



## QUICK CHANGE DISC HOLDERS

Type	Diameter	Shank	Max RPM	Std. Pkg.	SOFT	MEDIUM	FIRM
Type S	3/4"	1/4"	40,000	1	-	11169	-
	1"	1/4"	40,000	1	-	<b>11170</b>	-
	1-1/2"	1/4"	30,000	1	50257	<b>11171</b>	46310
	2"	1/4"	30,000	1	<b>11172</b>	<b>11173</b>	<b>11174</b>
	3"	1/4"	20,000	1	<b>11175</b>	<b>11176</b>	<b>11177</b>
	4"	1/4"	12,000	1	-	11178	-
Type R	3/4"	1/4"	40,000	1	-	<b>40564</b>	-
	1"	1/4"	40,000	1	-	<b>11273</b>	-
	1-1/2"	1/4"	30,000	1	50258	<b>11274</b>	51082
	2"	1/4"	30,000	1	<b>50254</b>	<b>11275</b>	<b>40821</b>
	3"	1/4"	20,000	1	<b>50420</b>	<b>11276</b>	<b>38308</b>
	4"	1/4"	12,000	1	-	<b>34992</b>	-

# SHUR-KUT® Coated

## Discs

Larger scale grinding and finishing in portable form, and shaping, deburring or blending against stationary grinders, SHUR-KUT® PSA and Hook & Loop discs offer several coated materials to match demanding metalworking applications. The PSA and Hook & loop fastening systems are easy to apply and remove for fast changeover, maintaining efficient productivity throughout production. Available in paper and cloth, both servicing a variety of industrial applications.

## Applications

- ▶ General purpose grinding and stock removal
- ▶ Flat surface leveling or parting line removal
- ▶ Weld removal and blending
- ▶ Paint preparation and finishing
- ▶ Handheld parts shaping
- ▶ Surface cleaning or corrosion removal





## Z<sub>A</sub> ZIRCONIA GRINDING AID CLOTH PSA DISCS



Tough, sharp and durable grains for extended life on high pressure, aggressive applications. Additional grinding aid to reduce friction and premature breakdown where heat generation is of concern.

- ▶ Aggressive grinding on stainless steel
- ▶ Dissipates heat and resists loading
- ▶ Quickly shape or recondition stainless steel and alloys

Diameter	Max RPM	Std. Pkg.	36	40	50	60	80	120
5"	12,000	50	<b>21372</b>	34014	<b>17127</b>	<b>21150</b>	<b>21151</b>	21153
6"	10,000	50	21176	26381	31349	24531	<b>16108</b>	21177
12"	1,720	25	<b>16728</b>	<b>16919</b>	<b>19277</b>	<b>16729</b>	<b>18943</b>	16056
20"	1,720	10	<b>21012</b>	<b>21013</b>	17152	<b>24686</b>	<b>17154</b>	-

● Ferrous   ● Non-Ferrous   ● Stainless   ● Exotic Alloys   ○ Plastics   ○ Composites

## Z<sub>A</sub> ZIRCONIA CLOTH PSA DISCS

Sharp, durable zirconia grains reduce friction causing excessive heat and loading. Long lasting, high pressure grains ideal for aggressive applications.

- ▶ Aggressive stock removal on hard metals
- ▶ Sharp cut reduces heat, friction and loading
- ▶ High pressure applications



Diameter	Max RPM	Std. Pkg.	36	40	50	60	80	120
5"	12,000	50	<b>17498</b>	<b>17499</b>	<b>17500</b>	<b>17501</b>	<b>17502</b>	<b>17504</b>
6"	10,000	50	<b>17505</b>	17506	17507	<b>17508</b>	<b>17509</b>	<b>17511</b>
12"	1,720	25	<b>17458</b>	<b>17459</b>	17460	<b>17461</b>	<b>17462</b>	40497
20"	1,720	10	17483	<b>17484</b>	17485	<b>17486</b>	17487	46648

● Ferrous   ● Non-Ferrous   ● Stainless   ● Exotic Alloys   ○ Plastics   ● Composites

## SHUR-KUT® Coated

**A<sup>o</sup> ALUMINUM OXIDE  
CLOTH PSA DISCS**

Dense, blocky grain well suited for general purpose grinding and stock removal. Durable use on ferrous, non-ferrous, stainless steels, alloys and non-metallics.

- ▶ General stock removal and shaping
- ▶ Spot weld removal or rough blending
- ▶ Leveling or blending imperfections

**▶ Superior Support**

A warmer disc is easier to remove from a platen or holder. Use a piece of scrap metal to heat the disc if not in actual use.

Diameter	Max RPM	Std. Pkg.	24	36	40	50	60	80	100	120	180	240	320
1/2"	22,000	100	-	-	-	-	11376	<b>11377</b>	11378	<b>11379</b>	<b>11380</b>	16685	16095
3/4"	22,000	100	-	-	-	11382	11383	<b>11384</b>	11385	<b>11386</b>	<b>11387</b>	<b>16955</b>	18509
1"	22,000	100	-	-	-	11389	11390	<b>11391</b>	<b>11392</b>	<b>11393</b>	11394	<b>18004</b>	<b>18508</b>
1-1/2"	20,000	100	-	11396	11397	11398	11399	<b>11400</b>	11401	<b>11402</b>	11404	<b>11405</b>	11406
2"	18,000	100	11407	11408	11409	<b>11410</b>	<b>11411</b>	<b>11412</b>	<b>11413</b>	<b>11414</b>	<b>11416</b>	<b>11417</b>	<b>11418</b>
3"	17,000	50	11419	<b>11420</b>	11421	11422	<b>11423</b>	<b>11424</b>	<b>11425</b>	<b>11426</b>	<b>11428</b>	<b>11429</b>	<b>11430</b>
4"	16,000	50	11431	11432	11433	11434	11435	<b>11436</b>	<b>11437</b>	11438	11440	11441	11442
5"	12,000	50	11443	<b>11444</b>	<b>11445</b>	<b>11446</b>	<b>11447</b>	<b>11448</b>	<b>11449</b>	<b>11450</b>	<b>11452</b>	<b>11453</b>	11454
6"	10,000	50	11455	<b>11456</b>	<b>11457</b>	<b>11458</b>	<b>11459</b>	<b>11460</b>	<b>11461</b>	<b>11462</b>	<b>11464</b>	<b>11465</b>	11466
8"	4,800	50	11476	<b>11477</b>	11478	11479	<b>11480</b>	<b>11481</b>	11482	<b>11483</b>	11484	30428	30430
9"	1,720	25	11485	<b>11486</b>	11487	11488	<b>11489</b>	<b>11490</b>	<b>11491</b>	<b>11492</b>	11493	-	-
10"	1,720	25	11494	<b>11495</b>	11496	11497	<b>11498</b>	<b>11499</b>	<b>11500</b>	<b>11501</b>	11502	30443	30444
12"	1,720	25	11503	<b>11504</b>	<b>11505</b>	<b>11506</b>	<b>11507</b>	<b>11508</b>	<b>11509</b>	<b>11510</b>	<b>11512</b>	11513	<b>11514</b>
16"	1,720	25	11533	<b>11534</b>	11535	11536	11537	<b>11538</b>	11539	11540	-	52928	-
18"	1,720	10	11542	11543	11544	11545	11546	11547	11548	11549	-	-	30463
20"	1,720	10	11551	<b>11552</b>	<b>11553</b>	<b>11554</b>	<b>11555</b>	<b>11556</b>	11557	11558	11559	-	-
24"	1,150	10	11560	<b>11561</b>	<b>11562</b>	11563	11564	11565	11566	11567	11568	53249	53250

● Ferrous ● Non-Ferrous ○ Stainless ○ Exotic Alloys ● Plastics ● Composites



## PSA CLOTH DISC HOLDERS

Used with pistol grip sanders or die grinders and up to 5" discs. Durable and flexible pad for moderate contouring and conformability.



Diameter	Shank	Max RPM	Std. Pkg.	Part #
1/2"	1/8"	30,000	1	<b>11701</b>
1/2"	1/4"	30,000	1	<b>11702</b>
3/4"	1/8"	30,000	1	<b>11703</b>
3/4"	1/4"	30,000	1	<b>11704</b>
1"	1/8"	30,000	1	<b>11705</b>
1"	1/4"	30,000	1	<b>11706</b>
1-1/2"	1/4"	30,000	1	<b>11707</b>
2"	1/4"	28,000	1	<b>11708</b>
3"	1/4"	20,000	1	<b>11709</b>
4"	1/4"	16,000	1	11710
5"	1/4"	12,000	1	11711



## SHUR-KUT® Coated

## A<sup>o</sup> ALUMINUM OXIDE GOLD PSA DISCS

General purpose grains on a C-weight paper backing, able to level small imperfections on most surfaces. Ideal for prep and sanding between coatings to ensure adhesion of smooth layers.

- ▶ Load resistant stearate
- ▶ Surface blending and leveling
- ▶ Prep between applied coatings
- ▶ Easy to remove PSA when finished

Diameter	Max RPM	Std. Pkg.	60	80	120
5"	12,000	100	<b>44838</b>	<b>39981</b>	40425
6"	10,000	100	<b>46654</b>	<b>40066</b>	40068

Ferrous  
  Non-Ferrous  
  Stainless  
  Exotic Alloys  
  Plastics  
  Composites



## A<sup>o</sup> ALUMINUM OXIDE GOLD HOOK & LOOP DISCS

Hook & loop fastening system makes disc changeover fast and easy without any adhesives. General purpose grains on a C-weight paper backing, ideal for prep and sanding between coatings to ensure adhesion of smooth layers.

- ▶ Load resistant stearate
- ▶ Surface blending and leveling
- ▶ Prep between applied coatings
- ▶ Quick changeover fastening system

Diameter	Max RPM	Std. Pkg.	60	80	120
5"	12,000	100	<b>44711</b>	<b>38835</b>	<b>40882</b>
6"	10,000	100	46655	40887	40889

Ferrous  
  Non-Ferrous  
  Stainless  
  Exotic Alloys  
  Plastics  
  Composites

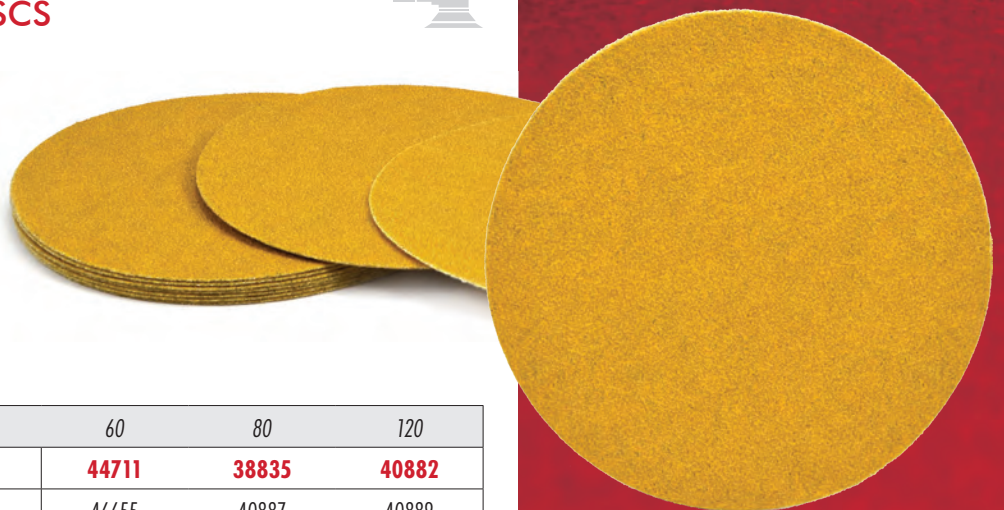

## A<sup>o</sup> ALUMINUM OXIDE GOLD PSA DISC ROLLS

Conveniently packaged in roll form with no backing liner to remove. General purpose grains on a C-weight paper backing, able to level small imperfections on most surfaces. Ideal for prep and sanding between coatings to ensure adhesion of smooth layers.

- ▶ Load resistant stearate
- ▶ Surface blending and leveling
- ▶ Prep between applied coatings



Diameter	Max RPM	Std. Pkg. (100 Discs/Roll)	80	100	120	150	180	220	240	320
5"	12,000	1 Roll	<b>25078</b>	<b>25079</b>	<b>25080</b>	<b>25081</b>	<b>25082</b>	<b>25083</b>	<b>25084</b>	<b>25085</b>
6"	10,000	1 Roll	<b>25086</b>	<b>25087</b>	<b>25088</b>	<b>25089</b>	<b>25090</b>	<b>25091</b>	-	<b>25093</b>

● Ferrous ● Non-Ferrous ○ Stainless ○ Exotic Alloys ● Plastics ● Composites

## A<sup>o</sup> ALUMINUM OXIDE BLUE STEARATE PSA DISC ROLLS

Added stearate acts as a lubricant to reduce loading or clogging. Reduced loading and prolonged disc life for larger preparation and finishing applications. Packaged in roll form for convenient use.

- ▶ Smooth surface cleaning or preparation
- ▶ Surface leveling and blending
- ▶ Load-resistant for softer metals



Diameter	Max RPM	Std. Pkg. (125 Discs/Roll)	80	120	150	180	220	320
5"	12,000	1 Roll	<b>11685</b>	<b>11687</b>	<b>11688</b>	<b>11689</b>	-	<b>11692</b>
6"	10,000	1 Roll	<b>11693</b>	<b>11695</b>	-	<b>11697</b>	<b>11698</b>	-

● Ferrous ● Non-Ferrous ○ Stainless ○ Exotic Alloys ● Plastics ● Composites



## HOOK & LOOP PAPER DISC HOLDERS



Diameter	Shank	Max RPM	Std. Pkg.	Part #
5"	5/16"-24	12,000	1	40910
6"	5/16"-24	10,000	1	40911



## PSA PAPER DISC HOLDERS



Diameter	Shank	Max RPM	Std. Pkg.	Part #
5"	5/16"-24	12,000	1	<b>11715</b>
6"	5/16"-24	10,000	1	<b>11716</b>

# SHUR-KUT® Coated

## Flap Discs

Overlapping layers of coated abrasives wear down to expose new cutting surfaces, allowing extended use of flap discs and much more control and comfort than rigid grinding wheels. The profile of flap discs, either flat faced (Type 27) or angle faced (Type 29) controls the amount of leverage applied to surfaces. Type 27 flap discs are better for finesse and extended use, whereas Type 29 discs are much more aggressive. Standard density discs provide less flap compression, best suited for stock removal and rough shaping. High density discs utilize more flaps, prolonging life, and are less compressed, allowing limited conformability to the workpiece.

## Applications

- ▶ Weld and heavy stock removal
- ▶ Rough shaping
- ▶ Edge grinding or beveling
- ▶ Weld blending and surface leveling





## Z<sub>A</sub> BLAC-KUT ZIRCONIA HIGH DENSITY FLAP DISCS



A cost efficient option to high density discs, Blac-Kut Flap Discs are manufactured with larger flaps, providing effective material removal with an extended product life. Available in Type 29, for beveling and removal, or Type 27 for flat grinding and blending.

- ▶ Larger flaps for greater surface contact
- ▶ Extra-long product life
- ▶ Aggressive stock removal on hard metals
- ▶ Sharp cut reduces heat, friction and loading
- ▶ High pressure applications

### ▶ Superior Support



Shape	Diameter	Arbor	Max RPM	Std. Pkg.	40	60	80
Type 29	4-1/2"	7/8"	13,300	10	<b>58848</b>	<b>58849</b>	<b>58850</b>
Type 27	4-1/2"	7/8"	13,300	10	<b>59820</b>	<b>55888</b>	<b>59815</b>

● Ferrous   ● Non-Ferrous   ● Stainless   ● Exotic Alloys   ○ Plastics   ○ Composites



## C<sub>A</sub> CERAMIC GRINDING AID FLAP DISCS



Self-sharpening grains continually produce fresh cutting points, reducing friction and prolonging cut rates. Additional grinding aid further reduces heat, extending disc life. Durable polyester backing retains grain orientation and contact pressure against stainless and exotic alloys.

- ▶ Additional heat dissipation for high temperature grinding
- ▶ Sharp grains cut through hard alloys
- ▶ Extended life and grain retention

Shape	Diameter	Arbor	Max RPM	Std. Pkg.	40	60	80
Type 29	4-1/2"	7/8"	13,300	10	<b>48300</b>	<b>48301</b>	<b>48302</b>
	4-1/2"	5/8"-11	13,300	10	<b>48304</b>	<b>48305</b>	<b>48306</b>
Type 27	4-1/2"	7/8"	13,300	10	48316	48317	48318
	4-1/2"	5/8"-11	13,300	10	48320	48321	48322

● Ferrous   ● Non-Ferrous   ● Stainless   ● Exotic Alloys   ○ Plastics   ○ Composites

## Z<sub>A</sub> ZIRCONIA HIGH DENSITY FLAP DISCS

Increased flap count provides moderate compression for better blending and finesse. Greater cutting area promotes extended life and consistent performance throughout use.

- ▶ Longer life for repeatable application
- ▶ Aggressive weld and stock removal
- ▶ Quickly blend flat and contoured seams
- ▶ Leveling or blending imperfections

### ▶ Superior Support

Flap compression allows conformability around contoured parts, increasing the versatility of flap discs.

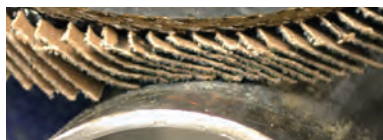

Shape	Diameter	Arbor	Max RPM	Std. Pkg.	40	60	80
Type 29	4-1/2"	7/8"	13,300	10	<b>28848</b>	<b>28849</b>	<b>28850</b>
Type 27	4-1/2"	7/8"	13,300	10	<b>39820</b>	<b>35888</b>	39815

● Ferrous   ● Non-Ferrous   ● Stainless   ● Exotic Alloys   ○ Plastics   ○ Composites

## Z<sub>A</sub> ZIRCONIA FLAP DISCS

Dense grains continually generate new cutting edges, ideal for long lasting stock removal. Sharp grains reduce heat and friction in high pressure applications.

- ▶ Aggressive stock removal on hard metals and alloys
- ▶ Sharp cut reduces heat, friction and heavy loading
- ▶ High pressure applications

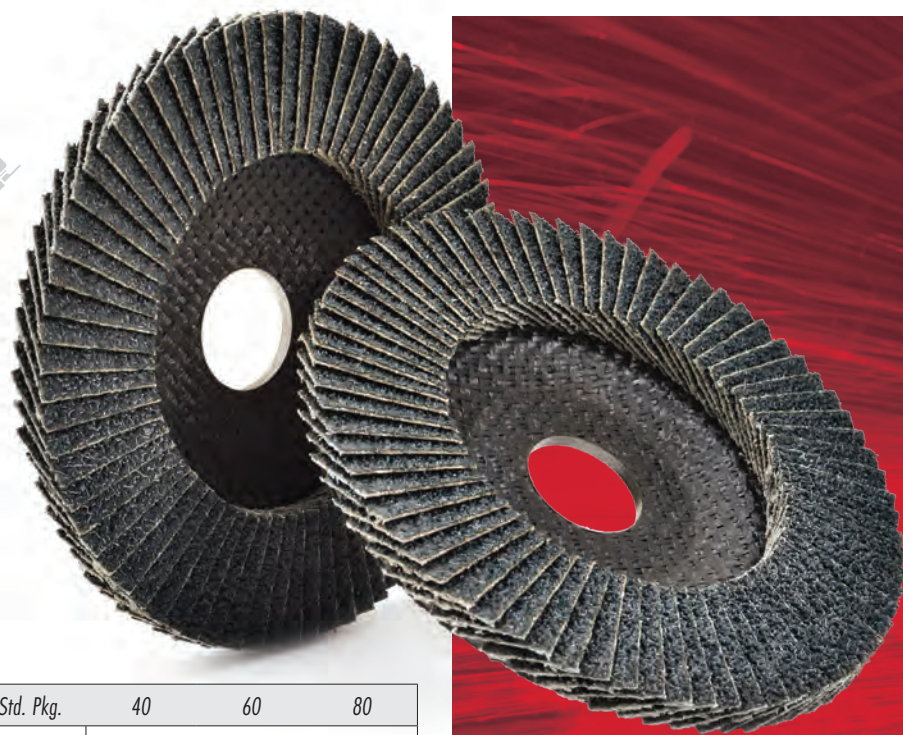

Shape	Diameter	Arbor	Max RPM	Std. Pkg.	40	60	80
Type 29	4-1/2"	7/8"	13,300	10	44028	<b>44029</b>	44030
Type 27	4-1/2"	7/8"	13,300	10	<b>34982</b>	<b>11823</b>	<b>11824</b>
	4-1/2"	5/8"-11	13,300	10	40572	<b>34324</b>	<b>34325</b>

● Ferrous   ● Non-Ferrous   ● Stainless   ● Exotic Alloys   ○ Plastics   ○ Composites

# A<sub>o</sub> ALUMINUM OXIDE HIGH DENSITY FLAP DISCS

Added layers of dense grains well suited for general purpose grinding and stock removal. Durable use on ferrous, non-ferrous, stainless steels, alloys and non-metallics. Ideal for mild steels and aluminum.

- ▶ General stock removal and shaping on most metals
- ▶ Increased flap count extends life
- ▶ Blending and beveling



Shape	Diameter	Arbor	Max RPM	Std. Pkg.	40	60	80
Type 29	4-1/2"	7/8"	13,300	10	<b>21950</b>	<b>21951</b>	<b>21952</b>

Ferrous  
  Non-Ferrous  
  Stainless  
  Exotic Alloys  
  Plastics  
  Composites



## SHUR-KUT® Coated

**Z<sub>A</sub> ZIRCONIA QUICK CHANGE MINI FLAP DISCS**

Small footprint for aggressive grinding and stock removal in smaller areas. Overlapping flaps wear away to fresh cutting surfaces, prolonging disc life and use. Quick change functionality alleviates production downtime.

- ▶ Aggressive removal in small areas
- ▶ Quick changeover between discs
- ▶ Sharp cuts reduce heat and loading
- ▶ High pressure applications



Type	Diameter	Max RPM	Optimal RPM	Std. Pkg.	36	40	60	80	120
Type R	2"	25,000	13,000	10	<b>37895</b>	<b>37896</b>	<b>37897</b>	<b>37898</b>	<b>37899</b>
	3"	20,000	9,000	10	<b>37905</b>	<b>37906</b>	<b>37907</b>	<b>37908</b>	<b>37909</b>

● Ferrous ○ Non-Ferrous ● Stainless ● Exotic Alloys ○ Plastics ● Composites

**Z<sub>A</sub> ZIRCONIA QUICK CHANGE MINI FLEX DISCS**

Less compressed flaps flex and conform to contours and inside corners and are easily finessed. Sharp zirconia grains reduce heat and friction in demanding applications.

- ▶ Durable, long-life zirconia grains
- ▶ Extended flaps reach small areas
- ▶ Conformable control for critical parts
- ▶ Quick change functionality for die grinders

**▶ Superior Support**

Take advantage of flex discs to reach tight areas.



Type	Diameter	Max RPM	Optimal RPM	Std. Pkg.	36	40	60	80	120
Type R	2"	25,000	13,000	10	<b>37865</b>	<b>37866</b>	<b>37867</b>	<b>37868</b>	<b>37869</b>
	3"	20,000	9,000	10	39271	<b>39272</b>	<b>39273</b>	<b>39274</b>	39275

● Ferrous ○ Non-Ferrous ● Stainless ● Exotic Alloys ○ Plastics ● Composites



# Ao ALUMINUM OXIDE QUICK CHANGE MINI FLEX DISCS

Compressible flaps extend outward to conform and reach small areas and run against inside corners. Durable use on ferrous, non-ferrous, stainless steels, alloys and non-metallics. Ideal for mild steels and aluminum.

- ▶ General purpose grinding and blending
- ▶ Flap overhang reaches small areas
- ▶ Conformable and controllable
- ▶ Quick change functionality for die grinders

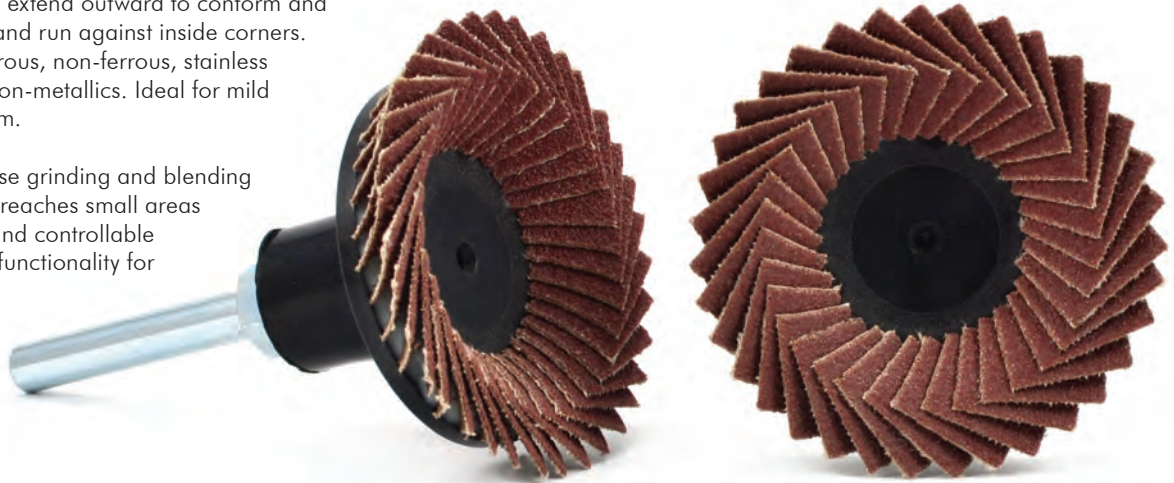

Type	Diameter	Max RPM	Optimal RPM	Std. Pkg.	36	40	60	80	120
Type R	2"	25,000	13,000	10	37860	<b>37861</b>	37862	<b>37863</b>	37864
	3"	20,000	9,000	10	39266	39267	39268	39269	39270

● Ferrous   ● Non-Ferrous   ● Stainless   ● Exotic Alloys   ○ Plastics   ● Composites

## QUICK CHANGE DISC HOLDERS

Type	Diameter	Shank	Max RPM	Std. Pkg.	Part #
Type R	2"	1/4"	25,000	1	<b>11275</b>
	3"	1/4"	20,000	1	<b>11276</b>



# SHUR-KUT® Coated

## Resin Fiber Discs

A dense, rigid backing is utilized for better grain retention and direct pressure from abrasive grains, creating a heavy duty, aggressive cutting action. Best for flat surfaces with minimal contours, resin fiber discs can provide the most aggressive and heavy stock removal of all coated abrasives. The substantial surface area minimizes time taken to finish large areas. Used with an air-cooled backing pad, heat is dissipated to reduce overheating and loading, providing a long life from resin fiber discs.

## Applications

- ▶ Grinding and heavy stock removal
- ▶ Weld removal and blending
- ▶ Surface leveling and shaping
- ▶ Shape and prep large cast parts

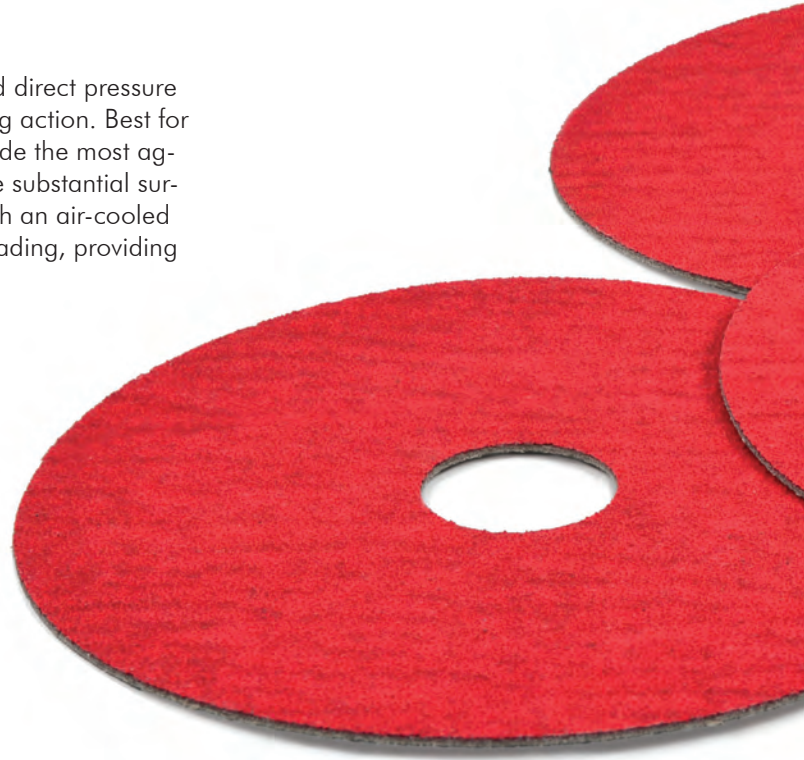



## CA CERAMIC GRINDING AID RESIN FIBER DISCS



Self-sharpening grains continually produce fresh cutting points, reducing friction and prolonging cut rates. Additional grinding aid further reduces heat, extending disc life. Densely pressed fiber backing retains grain orientation and contact pressure against stainless and exotic alloys.

- ▶ Additional heat dissipation for high temperature grinding
- ▶ Large surface area and coverage
- ▶ Sharp grains cut through hard alloys
- ▶ Extended life and grain retention

Diameter	Arbor	Max RPM	Optimal RPM	Std. Pkg.	24	36	50	60	80
4-1/2"	7/8"	13,300	8,000	25	43582	<b>43583</b>	43830	<b>43553</b>	<b>43831</b>
5"	7/8"	13,000	7,000	25	42965	<b>42966</b>	<b>42967</b>	<b>42655</b>	<b>41929</b>
7"	7/8"	8,600	5,400	25	40703	<b>40704</b>	42390	<b>40705</b>	<b>42969</b>

Ferrous  
  Non-Ferrous  
  Stainless  
  Exotic Alloys  
  Plastics  
  Composites

## ZA ZIRCONIA RESIN FIBER DISCS

Dense grains continually generate new cutting edges, ideal for long lasting stock removal. Rigid backing provides additional pressure for sharp grains to break down properly.

- ▶ Aggressive stock removal on hard metals and alloys
- ▶ Sharp cut reduces heat, friction and loading
- ▶ High pressure applications

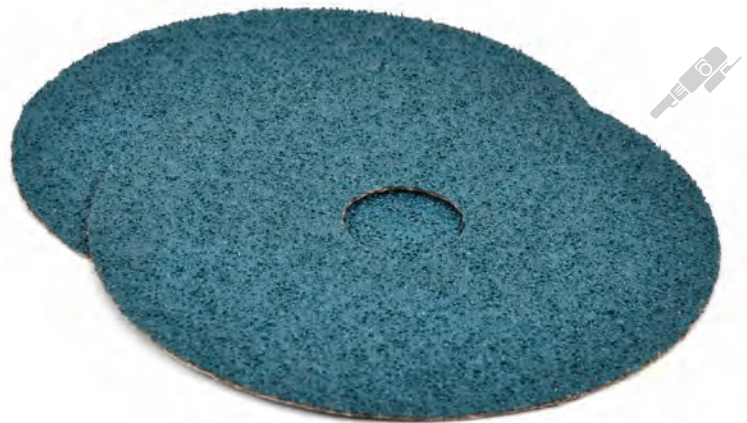

Diameter	Arbor	Max RPM	Optimal RPM	Std. Pkg.	24	36	50	60	80
4-1/2"	7/8"	13,300	8,000	25	11748	<b>11749</b>	<b>11750</b>	<b>11751</b>	<b>11752</b>
5"	7/8"	13,000	7,000	25	<b>11753</b>	<b>11754</b>	<b>11755</b>	11756	<b>11757</b>
7"	7/8"	8,600	5,400	25	<b>11758</b>	<b>11759</b>	<b>11760</b>	<b>11761</b>	11762

Ferrous  
  Non-Ferrous  
  Stainless  
  Exotic Alloys  
  Plastics  
  Composites

# SHUR-KUT® Coated

## A<sub>o</sub> ALUMINUM OXIDE RESIN FIBER DISCS

Tough, blocky grain well suited for general purpose grinding and stock removal. Rigid pressure cuts faster. Durable use on ferrous, non-ferrous, stainless steels, alloys and non-metallics.

- ▶ General stock removal and shaping
- ▶ Weld removal and blending
- ▶ Leveling or blending imperfections

### ▶ Superior Support

Flexible and rigid back up pads are offered to improve performance in unique operations. Additional flexibility may be helpful when blending welds in tanks or vessels.



Diameter	Arbor	Max RPM	Optimal RPM	Std. Pkg.	24	36	50	60	80	120
4-1/2"	7/8"	13,300	8,000	25	<b>11718</b>	<b>11719</b>	<b>11720</b>	<b>11721</b>	<b>11722</b>	<b>11724</b>
5"	7/8"	13,000	7,000	25	<b>11726</b>	<b>11727</b>	<b>11728</b>	<b>11729</b>	<b>11730</b>	<b>11732</b>
7"	7/8"	8,600	5,400	25	<b>11734</b>	<b>11735</b>	11736	<b>11737</b>	<b>11738</b>	11740

● Ferrous ● Non-Ferrous ○ Stainless ○ Exotic Alloys ○ Plastics ● Composites

### BACK UP PADS

Air-cooled design dissipates generated heat during grinding, reducing loading and extending life.



Diameter	Arbor	Max RPM	Std. Pkg.	FLEXIBLE	MEDIUM	RIGID
4-1/2"	5/8"-11	13,500	1	-	<b>11847</b>	-
5"	5/8"-11	13,000	1	-	<b>11850</b>	-
7"	5/8"-11	8,600	1	11852	<b>11853</b>	<b>11854</b>
Retainer Nut			1		<b>11858</b>	
Spanner Wrench			1		<b>11859</b>	

\*Nut and wrench not supplied with back up pad.



### FIBER DISC CUTTER

Reuse larger discs by removing the outer diameter, effectively doubling or tripling disc life.



▶ Superior Support

Description	Std. Pkg.	Part #
Disc Cutter & Blades	1	<b>12142</b>
Replacement Upper Blade	1	<b>12143</b>
Replacement Lower Blade	1	<b>12144</b>

# SHUR-KUT® Coated

## Belts

Due to the size range of coated belts, applications range from small inside corner weld removal to coil and sheet steel surface finishing. The availability of backing weight and flexibility allows use with small airfile contact wheels to larger diameter drum or cylindrical grinding. Durability also prevents stretch or slack in backstand applications, allowing coated materials to perform properly with consistent wear.

## Applications

- ▶ High production processing and polishing
- ▶ Flat surface prep and leveling
- ▶ Weld removal and blending
- ▶ Cylindrical grinding and polishing
- ▶ Surface cleaning or corrosion removal

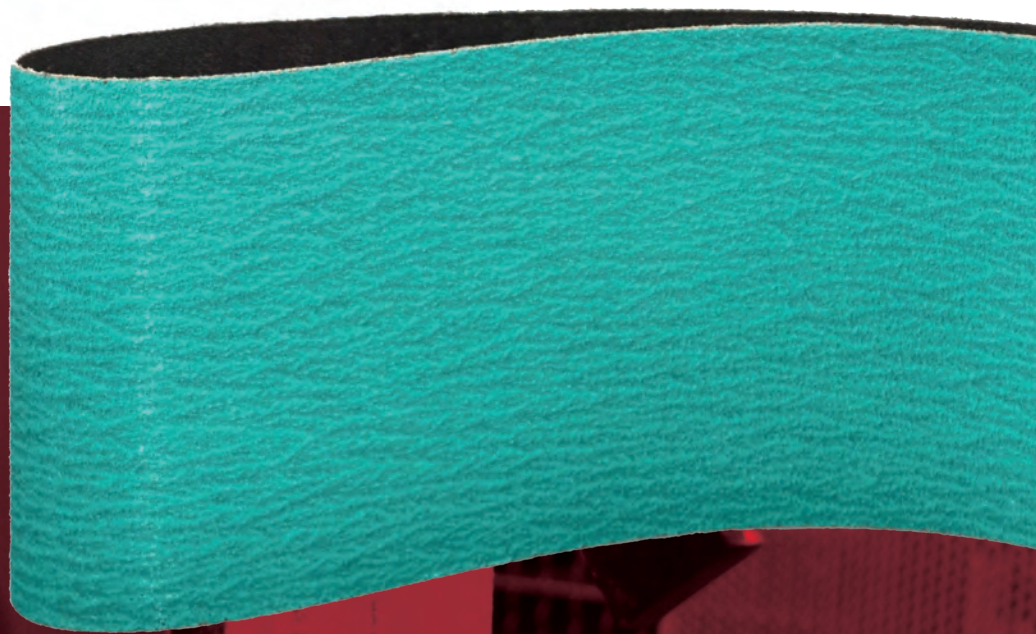

## **CA** CERAMIC GRINDING AID BELTS



Self-sharpening grains continually produce fresh cutting points, reducing friction and prolonging cut rates under lighter pressure. Additional grinding aid further reduces heat, extending belt life.

- ▶ Additional heat dissipation for high temperature grinding
- ▶ Sharp grains cut through stainless steel and alloys
- ▶ Extended life and grain retention

Width	Length	Std. Pkg.	40	60	80	120
1/2"	24"	50	52426	47679	49125	49054
3/4"	18"	50	52427	49269	52428	52429
3/4"	20-1/2"	50	51150	49128	49129	52430
1"	42"	50	52431	50433	52432	52433
2"	48"	50	52434	52435	52436	52437
2-1/2"	60"	50	52438	52439	52440	52441
3"	132"	50	52442	51042	51541	52443
6"	48"	10	52444	49154	51726	52445

● Ferrous ● Non-Ferrous ● Stainless ● Exotic Alloys ○ Plastics ○ Composites

## **ZA** ZIRCONIA GRINDING AID BELTS



Tough, durable grains for extended life on high pressure applications. Continually sharp cutting surfaces provide excellent cut in finishing and polishing applications. Additional grinding aid to reduce friction and premature breakdown where heat generation is of concern.

- ▶ Aggressive, sharp cut on stainless steel
- ▶ Dissipates heat and resists loading
- ▶ Extended performance and stock removal
- ▶ Fresh cutting edges exposed during use

Width	Length	Std. Pkg.	40	60	80	120
1/2"	24"	50	28346	27445	28347	28349
3/4"	18"	50	30500	27500	27473	52421
3/4"	20-1/2"	50	36794	28097	36795	36796
1"	42"	50	30505	30506	30507	30510
2"	48"	50	52422	30512	27107	30513
2-1/2"	60"	50	52423	30522	30523	52424
3"	132"	50	22400	26232	32003	52425
6"	48"	10	32009	<b>32062</b>	<b>18912</b>	<b>32063</b>

● Ferrous ● Non-Ferrous ● Stainless ● Exotic Alloys ○ Plastics ○ Composites

## Ao ALUMINUM OXIDE BELTS



Dense, blocky grain well suited for general purpose grinding and stock removal. Airfile belts easily reach narrow areas inaccessible by discs or wheels. Durable use on ferrous, non-ferrous, stainless steels, alloys and non-metallics.

- ▶ General stock removal and shaping
- ▶ Cylindrical shaping or conditioning
- ▶ Inside corner weld removal
- ▶ Deburring handheld parts



Width	Length	Std. Pkg.	36	40	50	60	80	100	120	180
3/8"	13"	50 (*200)	10667*	10668*	10669*	<b>10670</b>	<b>10671</b>	10672*	10673*	10674*
1/2"	12"	50 (*200)	10675*	10676*	10677*	<b>10678</b>	<b>10679</b>	10680*	<b>10681</b>	10682*
1/2"	18"	50 (*200)	14384*	14385*	14386*	<b>14387</b>	<b>14388</b>	14389*	<b>14390</b>	14392*
1/2"	24"	50 (*200)	10683	<b>10684</b>	10685*	<b>10686</b>	<b>10687</b>	10688*	<b>10689</b>	10690*
3/4"	18"	50 (*200)	10691	<b>10692</b>	10693*	<b>10694</b>	<b>10695</b>	10696*	<b>10697</b>	10698*
3/4"	20-1/2"	50 (*200)	10699*	10700*	10701*	<b>10702</b>	<b>10703</b>	10704*	10705*	10706*
1"	42"	50	10735	43834	10737	<b>43835</b>	<b>43836</b>	43837	43838	43839
1-1/8"	21"	50	10744	10745	10746	10747	10748	10749	10750	28224
1-1/2"	60"	50	10753	10754	10755	<b>10756</b>	10757	10758	10759	10760
1-1/2"	72"	50	10762	10763	10764	10765	10766	10767	10768	28104
2"	20"	50	10771	10772	10773	10774	10775	10776	10777	10778
2"	48"	50	10780	10781	10782	<b>10783</b>	<b>10784</b>	10785	10786	10787
2"	60"	50	10789	10790	10791	10792	10793	10794	10795	10796
2"	132"	50	10807	10808	10809	10810	10811	10812	10813	10814
2-1/2"	48"	50	10816	10817	10818	10819	10820	10821	10822	27734
2-1/2"	60"	50	10825	10826	10827	10828	10829	10830	10831	10832
2-1/2"	72"	50	10834	10835	10836	10837	10838	10839	10840	10841
3"	18"	50	10843	10844	10845	10846	10847	10848	10849	10850
3"	60"	50	10870	10871	10872	10873	10874	10875	10876	10877
3"	72"	50	10879	10880	10881	10882	10883	34898	10884	10886
3"	90"	50	10888	10889	10890	10891	10892	10893	10894	10895
3"	132"	50	10897	10898	10899	10900	10901	10902	10903	10904
3"	168"	50	10906	10907	10908	10909	10910	10911	10912	28161
3-1/2"	15-1/2"	50	10915	10916	10917	10918	10919	10920	10921	10922
4"	21"	50	10924	10925	10926	10927	10928	10929	10930	20977
4"	21-3/4"	50	10933	10934	10935	10936	10937	10938	10939	10940
4"	54"	50	10960	10961	10962	10963	10964	10965	10966	10967
6"	48"	20	43840	<b>43841</b>	43842	<b>43843</b>	<b>43844</b>	43845	<b>43846</b>	11039

● Ferrous ● Non-Ferrous ● Stainless ○ Exotic Alloys ○ Plastics ○ Composites



## A<sub>o</sub> ALUMINUM OXIDE WIDE BELTS



Wide belts fit a wide range of stationary equipment for high production processing. Greater surface area and longer life with consistent finishing qualities. Dense, blocky grain well suited for general purpose grinding and stock removal. Durable use on ferrous, non-ferrous, stainless steels, alloys and non-metallics.

- ▶ Aggressive, general purpose cutting action
- ▶ Leveling surface imperfections
- ▶ High production grinding or polishing



Width	Length	Std. Pkg.	36	40	50	60	80	100	120	180
18"	85"	5	24353	24354	24355	24356	24357	24358	24359	24360
19"	48"	5	26100	38436	38437	38438	21357	37938	25289	28254
25"	60"	5	24379	24380	24381	24382	24383	24384	24385	24386
25"	75"	5	24391	24392	24393	24164	24394	24395	24165	24396
30"	103"	5	24398	24399	24400	24401	24402	24403	21681	24404
36"	60"	5	24406	24407	24408	24409	24410	24411	24412	24413
36"	75"	5	24417	24418	24419	24420	18704	24421	24422	24423
37"	60"	5	24425	22886	17150	21649	17151	16723	30361	22888
37"	75"	5	24427	24428	24429	18975	18976	24430	24167	24168
50"	103"	5	24432	24433	24434	24435	24436	24437	24438	24439
52"	75"	5	24441	24442	24443	24444	24445	24446	24447	24448
52"	103"	5	24459	24460	24461	24462	24463	24464	24465	24466

● Ferrous ● Non-Ferrous ● Stainless ○ Exotic Alloys ○ Plastics ○ Composites

# SHUR-KUT® Coated

## Flap Wheels

Flexible flaps are arranged radially around a center core allowing high removal and finishing rates with reduced pressure and fatigue from operators. The flexibility of the flaps allows excellent control and conformability on contours and inside or around intricate parts. As the grains wear away, so does the cloth backing, continually exposing fresh abrasive material and sharp cutting grains. The variety of shapes and sizes available provide versatility in grinding, deburring and polishing flat or contoured surfaces and edges. Several mounting options are available for many tools, including right angle grinders.

## Applications

- ▶ Contoured grinding and finishing
- ▶ Inner tube deburring, cleaning and polishing
- ▶ Shaping or refining contours on cast or machined parts
- ▶ Weld seam blending or finishing
- ▶ Straight line finishing and surface preparation

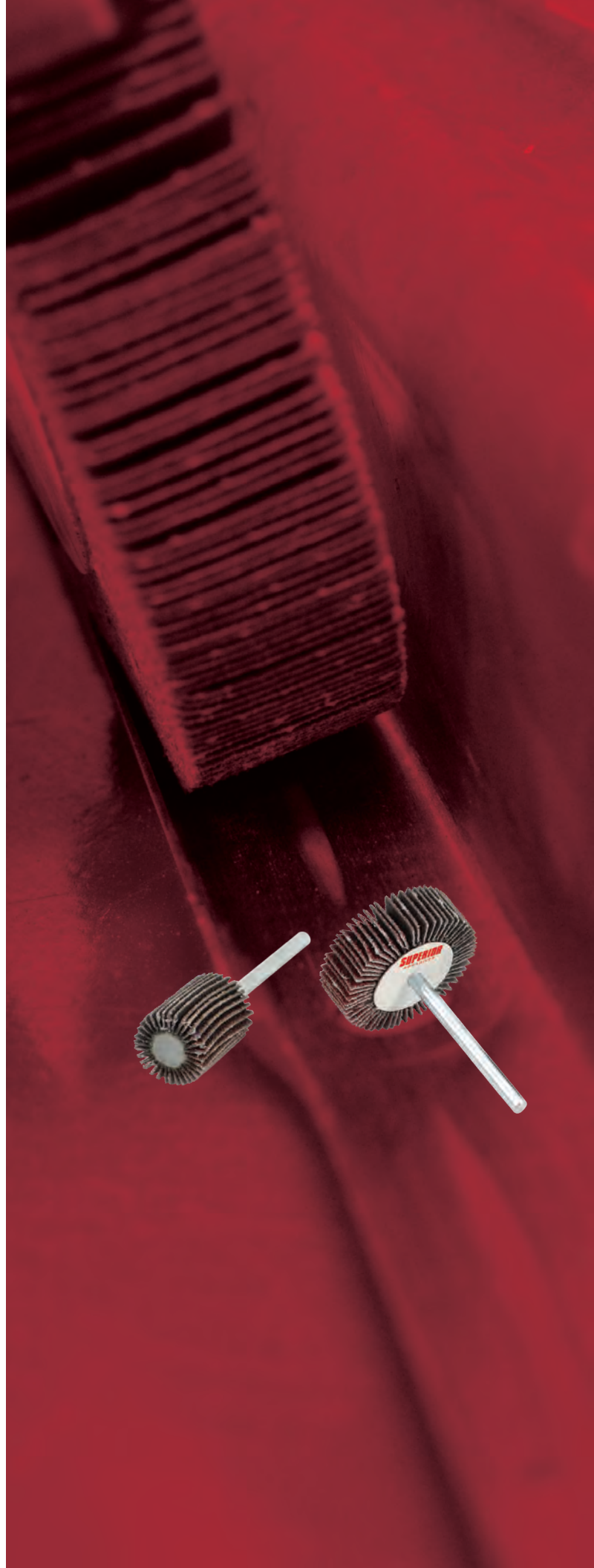

# Ao FLAP WHEELS FOR ANGLE GRINDERS

Portable, large diameter flap wheel conforms to right angles to remove or refine inside corner welds, clean or refine narrow channels or extrusions. Quick change hub for use with right angle grinders.

- ▶ Narrow profile with extended flaps
- ▶ Easily refine or prep deeper channels
- ▶ Strong, flexible cloth backing wears uniformly
- ▶ Quick changeover between other right angle wheels or discs

### ▶ Superior Support

The low profile of flap wheels are excellent for working very close to edges and corners without damaging surrounding surfaces.



Diameter	Width	Arbor	Max RPM	Optimal RPM	Std. Pkg.	40	60	80	120
4-1/2"	3/4"	5/8"-11	13,300	7,500	2	<b>54801</b>	<b>54802</b>	<b>54803</b>	<b>54804</b>

● Ferrous   ● Non-Ferrous   ● Stainless   ○ Exotic Alloys   ● Plastics   ○ Composites



# Ao MINI MOUNTED FLAP WHEELS



Access and finish small and intricate openings and contours. Flexible flaps conform to acute angles and wear uniformly for consistent parts finishing. Ideal for reshaping or cleaning intricate cast parts.

- ▶ Easily access small openings or channels
- ▶ Continual grain exposure throughout product life
- ▶ Flexibility to contours and intricate parts

Diameter	Width	Shank	Max RPM	Optimal RPM	Std. Pkg.	80	120	180	240	320
3/8"	3/8"	1/8"	40,000	30,000	10	<b>24791</b>	<b>24802</b>	<b>24803</b>	<b>24804</b>	<b>24805</b>
5/8"	5/8"	1/8"	40,000	30,000	10	<b>24806</b>	<b>24807</b>	<b>24808</b>	<b>24809</b>	<b>24810</b>
5/8"	3/4"	1/8"	40,000	30,000	10	<b>24811</b>	<b>24812</b>	<b>24813</b>	<b>24814</b>	-
3/4"	5/8"	1/8"	38,100	19,000	10	<b>24816</b>	<b>24817</b>	24818	24819	-
3/4"	3/4"	1/8"	38,100	19,000	10	<b>24821</b>	<b>24822</b>	<b>24823</b>	<b>24824</b>	<b>24825</b>
1-3/16"	1/8"	1/8"	25,000	12,000	10	<b>24826</b>	<b>24827</b>	24828	24829	-
1-3/16"	3/16"	1/8"	25,000	12,000	10	<b>24832</b>	<b>24833</b>	24834	24835	-
1-3/16"	3/8"	1/8"	25,000	12,000	10	<b>24837</b>	<b>24838</b>	24839	<b>24840</b>	-

● Ferrous   ● Non-Ferrous   ● Stainless   ○ Exotic Alloys   ● Plastics   ○ Composites

## Ao MOUNTED FLAP WHEELS

Reach small ports or channels and easily navigate contours for grinding, deburring or polishing. Flaps wear evenly exposing fresh cuts throughout life. Several sizes available to match workpieces.

- ▶ Contoured grinding and finishing
- ▶ Inner tube deburring, cleaning and polishing
- ▶ Shaping or refining contours on cast or machined parts
- ▶ Weld seam blending or finishing



Diameter	Width	Shank	Max RPM	Optimal RPM	Std. Pkg.	40	60	80	120	180	240	320
3/4"	3/4"	1/4"	38,100	19,000	10	44406	<b>21881</b>	<b>21882</b>	<b>33358</b>	26874	-	-
1"	5/8"	1/4"	25,000	15,000	10	-	<b>10101</b>	<b>10102</b>	<b>10103</b>	-	-	-
1"	1"	1/4"	25,000	15,000	10	18593	<b>10104</b>	<b>10105</b>	<b>10106</b>	<b>10107</b>	<b>17116</b>	<b>16952</b>
1-1/2"	1/2"	1/4"	23,000	9,600	10	-	<b>10108</b>	<b>10109</b>	<b>10110</b>	16037	50664	53333
1-1/2"	1"	1/4"	23,000	9,600	10	31198	<b>10114</b>	<b>10115</b>	<b>10116</b>	<b>10117</b>	31201	47589
2"	1/2"	1/4"	23,000	7,000	10	-	<b>10118</b>	<b>10119</b>	<b>10120</b>	55293	-	-
2"	1"	1/4"	23,000	7,000	10	<b>10124</b>	<b>10125</b>	<b>10126</b>	<b>10127</b>	<b>10128</b>	<b>10129</b>	16293
2"	1-1/2"	1/4"	15,000	7,000	10	31257	<b>10130</b>	<b>10131</b>	10132	-	-	-
2-1/2"	1"	1/4"	23,000	6,300	10	18445	<b>10136</b>	<b>10137</b>	<b>10138</b>	10139	52745	54602
3"	1/2"	1/4"	20,000	4,800	10	16283	<b>10142</b>	<b>10143</b>	<b>10144</b>	31369	50085	49881
3"	1"	1/4"	20,000	4,800	10	<b>10148</b>	<b>10149</b>	<b>10150</b>	<b>10151</b>	<b>10152</b>	<b>10153</b>	-
3"	2"	1/4"	6,000	4,800	10	31474	<b>10157</b>	<b>10158</b>	<b>10159</b>	16930	-	31479

● Ferrous   ● Non-Ferrous   ● Stainless   ○ Exotic Alloys   ● Plastics   ○ Composites

## Ao 10-PIECE FLAP WHEEL TEST KIT

A variety of the most popular shank mounted flap wheels to match several applications in one convenient test kit.

Size	60	80	120	180	Std. Pkg.	Part #
1 x 1 x 1/4"	1	1	1	-	1	<b>28799</b>
2 x 1 x 1/4"	1	1	1	1		
3 x 1 x 1/4"	1	1	1	-		

● Ferrous   ● Non-Ferrous   ● Stainless   ○ Exotic Alloys   ● Plastics   ○ Composites



# Flap Wheels

## Ao THREADED MOUNTED FLAP WHEELS



Quick change threaded mandrel provides fast changeover between worn and new wheels, or between sizes and grits. Flaps wear evenly exposing fresh cuts throughout life. Used with a threaded mandrel adapter, no extra tooling is necessary.

- ▶ Contoured grinding and finishing
- ▶ Inner tube deburring, cleaning and polishing
- ▶ Shaping or refining contours on cast or machined parts
- ▶ Weld seam blending or finishing



Diameter	Width	Shank	Max RPM	Optimal RPM	Std. Pkg.	60	80	120
1"	5/8"	1/4"-20	25,000	15,000	10	<b>10160</b>	<b>10161</b>	<b>10162</b>
1"	1"	1/4"-20	25,000	15,000	10	<b>10163</b>	<b>10164</b>	<b>10165</b>
1-1/2"	1/2"	1/4"-20	23,000	9,600	10	<b>10167</b>	<b>10168</b>	<b>10169</b>
1-1/2"	1"	1/4"-20	23,000	9,600	10	<b>10173</b>	<b>10174</b>	<b>10175</b>
2"	1/2"	1/4"-20	23,000	7,000	10	<b>10177</b>	<b>10178</b>	<b>10179</b>
2"	1"	1/4"-20	23,000	7,000	10	<b>10184</b>	<b>10185</b>	<b>10186</b>
2-1/2"	1"	1/4"-20	23,000	6,300	10	10192	10193	-
3"	1/2"	1/4"-20	20,000	4,800	10	10196	<b>10197</b>	10198
3"	1"	1/4"-20	20,000	4,800	10	<b>10203</b>	10204	<b>10205</b>

● Ferrous   ● Non-Ferrous   ● Stainless   ○ Exotic Alloys   ● Plastics   ○ Composites

## THREADED MANDREL ADAPTER



Quick change mandrel alleviating the need for additional tooling when replacing worn wheels or exchanging sizes and grits. Used with threaded mounted flap wheels.



Connector	Shank	Overall Length	Std. Pkg.	Part #
1/4"-20 Female	1/4"	1-3/4"	1	<b>10208</b>

● Best   ● Better   ○ Good

[www.superiorabrasives.com](http://www.superiorabrasives.com)

STOCK ITEMS IN **RED** | Additional Items Available

# Ao MOUNTED FLAP MOP WHEELS

Slotted flaps increase ability to conform to edges and contours. The softer J-weight cloth backing flexes over irregular surfaces easily. Easily navigate intricate shapes without damage.

- ▶ Deburr and polish irregular surfaces
- ▶ Added control and finesse
- ▶ Controlled finishing of intricate parts

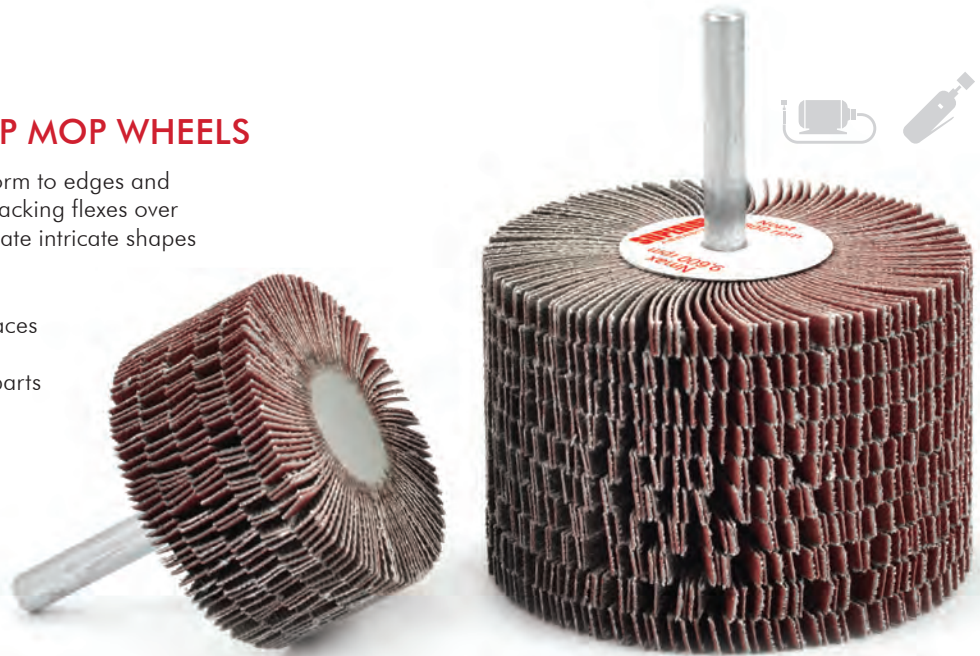

Diameter	Width	Shank	Max RPM	Optimal RPM	Std. Pkg.	120	180	240	320
2"	1"	1/4"	20,000	12,000	10	<b>28967</b>	<b>28968</b>	<b>28969</b>	<b>28970</b>
2-1/2"	1-1/2"	1/4"	18,000	11,000	10	<b>28971</b>	<b>28973</b>	<b>28974</b>	<b>28953</b>
3"	2"	1/4"	9,600	5,800	5	<b>28954</b>	<b>28955</b>	<b>28145</b>	<b>28956</b>

Ferrous  
  Non-Ferrous  
  Stainless  
  Exotic Alloys  
  Plastics  
  Composites

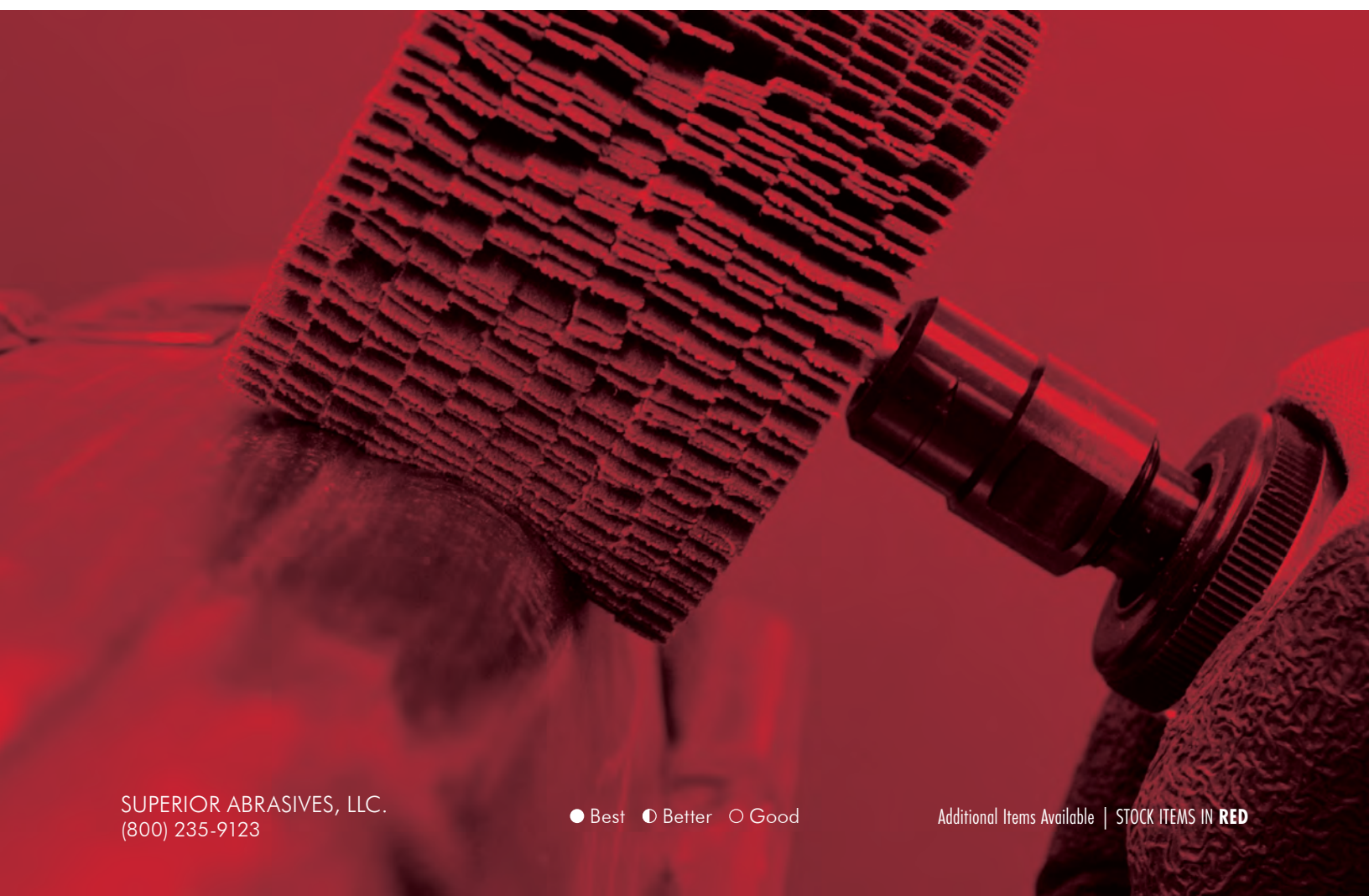

# Ao UNMOUNTED FLAP WHEELS

Spindle mounted wheels used with stationary equipment or adaptable handheld tools. Shape, finish and polish handheld parts, or produce linear finishes on flat parts. Longer, more flexible flaps finesse and conform to contours and smaller parts.

- ▶ Contoured grinding and finishing
- ▶ Shaping or refining contours on cast or machined parts
- ▶ Weld seam blending or finishing
- ▶ Straight line finishing and surface preparation

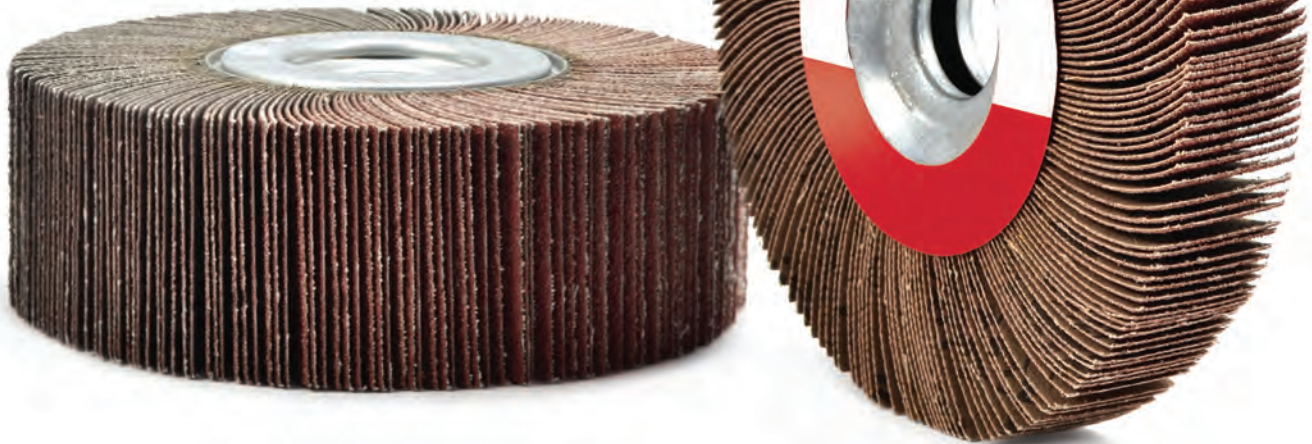

Diameter	Width	Arbor	Max RPM	Optimal RPM	Std. Pkg.	40	50	60	80	120	180
4"	1"	5/8"	8,600	8,000	5	53220	-	26269	26270	26272	26273
4"	2"	5/8"	8,600	8,000	5	-	26279	26280	26281	26282	26283
6"	1"	1"	5,700	5,000	5	26289	26290	<b>26291</b>	<b>26292</b>	<b>26294</b>	<b>26296</b>
6"	2"	1"	5,700	5,000	5	<b>26304</b>	<b>26305</b>	<b>26306</b>	<b>26307</b>	26309	26310
8"	1"	1"	4,300	3,800	3	52787	-	<b>26315</b>	26316	26318	26319

● Ferrous   ● Non-Ferrous   ● Stainless   ○ Exotic Alloys   ● Plastics   ○ Composites

## ARBOR REDUCER BUSHINGS



Arbor Diameter	Reduced Diameter	Std. Pkg.	Part #
1"	3/4"	1 Pair	10391
1"	5/8"	1 Pair	<b>10392</b>
1"	1/2"	1 Pair	<b>10393</b>



# SHUR-KUT® Coated

## Bore Polishers

Specially made for inside diameter tube and cylinders, bore polishers utilize precise flap spacing, ensuring balanced operation. Evenly spaced, the flaps act as a self-centering device to provide equal pressure to the surrounding cylinder, which can be utilized for smoothing and cleaning. Bore polishers are ideal for deburring or cleaning cylinders, tubes or hydraulic fittings.

## Applications

- ▶ Self-centered, flush wall grinding or polishing
- ▶ Inside diameter use only
- ▶ Deburring cut tube
- ▶ Boring cylinder walls
- ▶ Cleaning hydraulic fittings

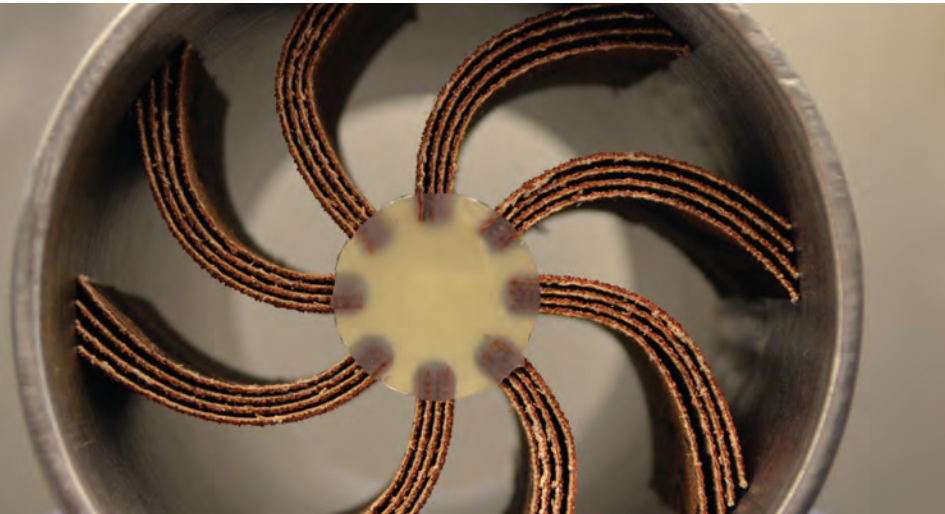
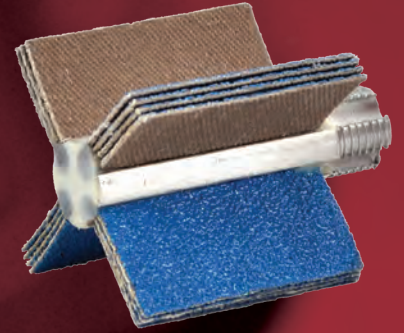

## BORE POLISHER MANDRELS

Series	Thread	Shank Diameter	Overall Length	Std. Pkg.	Part #
SK-3	5/16"-18	1/4"	2"	1	<b>39204</b>
SK-4	1/2"-20	1/4"	3"	1	<b>39205</b>
SK-8	1/4"-20	1/4"	2"	1	<b>39206</b>
	1/4"-20	1/4"	4"	1	<b>39207</b>
	1/4"-20	1/4"	6"	1	<b>39208</b>
	1/4"-20	1/4"	8"	1	<b>39209</b>



# Bore Polishers



## Z<sub>A</sub> ZIRCONIA BORE POLISHERS



Sharp, durable zirconia grains reduce the friction that causes excessive heat and loading. Long lasting, precise cutting action ideal for stainless steels.

- ▶ Clean or polish cylinder walls
- ▶ Refining machined inner diameters
- ▶ Recondition hydraulic fittings

Series	Min ID	Max ID	Thread	Max RPM	Std. Pkg.	60	80	120	180
SK-3	3/4"	1"	5/16"-18	25,000	10	46169	46170	46171	46172
SK-4	1"	1-1/2"	1/2"-20	22,000	10	46173	46174	46175	46176
	1-1/2"	2"	1/2"-20	20,000	10	<b>46177</b>	46178	46179	46180
	2-1/8"	2-1/2"	1/2"-20	16,000	10	17218	17219	17220	17221
	2-1/2"	3"	1/2"-20	15,000	10	46181	46182	46183	46184
SK-8	3-1/8"	4"	1/4"-20	10,000	10	46195	46196	46197	46239

● Ferrous   ● Non-Ferrous   ● Stainless   ● Exotic Alloys   ○ Plastics   ● Composites



## A<sub>O</sub> ALUMINUM OXIDE BORE POLISHERS



Strong, blocky grain used in general purpose operations, or where critical finish is not required. Easily clean and refurbish cylinder walls and inside tube.

- ▶ Clean and smooth cylinder walls
- ▶ Deburr pipe and tubing
- ▶ Clean or repair hydraulic fittings

Series	Min ID	Max ID	Thread	Max RPM	Std. Pkg.	60	80	120	180
SK-3	3/4"	1"	5/16"-18	25,000	10	<b>39161</b>	<b>39162</b>	<b>39163</b>	<b>39164</b>
SK-4	1"	1-1/2"	1/2"-20	22,000	10	<b>39165</b>	<b>39166</b>	<b>39117</b>	<b>39167</b>
	1-1/2"	2"	1/2"-20	20,000	10	<b>39168</b>	<b>39169</b>	<b>39170</b>	<b>39171</b>
	2-1/8"	2-1/2"	1/2"-20	16,000	10	<b>39172</b>	<b>39173</b>	39174	39175
	2-1/2"	3"	1/2"-20	15,000	10	<b>39176</b>	<b>39177</b>	<b>39178</b>	39179
	3-1/8"	4"	1/2"-20	10,000	10	39180	<b>39181</b>	39182	39183
SK-8	2"	2-1/2"	1/4"-20	16,000	10	39184	<b>39185</b>	39186	39187
	2-5/8"	3"	1/4"-20	15,000	10	39188	<b>39189</b>	<b>39190</b>	39191
	3-1/8"	4"	1/4"-20	10,000	10	<b>39192</b>	<b>39193</b>	<b>39194</b>	<b>39195</b>
	4-1/4"	5-1/4"	1/4"-20	8,000	10	39196	<b>39197</b>	39198	39199
	5-1/4"	5-7/8"	1/4"-20	8,000	10	39200	<b>39201</b>	39202	39203

● Ferrous   ● Non-Ferrous   ● Stainless   ○ Exotic Alloys   ● Plastics   ○ Composites

STOCK ITEMS IN **RED** | Additional Items Available

● Best   ● Better   ○ Good

[www.superiorabrasives.com](http://www.superiorabrasives.com)

# SHUR-KUT® Coated

## Cartridge Rolls

Specially wrapped design produces new layers of fresh cutting action throughout life as top layers are worn away. For shaping, porting, finishing or polishing hard to reach areas. Cotton cloth acts as a cushion for polishing in finer grits. Many diameters are available to match or enlarge existing contours, while straight or tapered designs are also available for through holes or inside corner grinding.

## Applications

- ▶ Long lasting grinding and shaping
- ▶ Polishing intricate contours or holes
- ▶ Shaping and rounding inside corner welds
- ▶ Porting and smoothing cast parts



## CA CERAMIC STRAIGHT CARTRIDGE ROLLS

Self-sharpening grains continually produce fresh cutting points, reducing friction and prolonging cut rates. Additional grinding aid further reduces heat, extending life. Multiple layers wear away to expose fresh abrasive material, further extend life.

- ▶ Sharp grains cut easily through stainless steel and alloys
- ▶ Fine cut for refined finishing results
- ▶ Extended wear for reduced downtime



Diameter	Length	Pilot Hole	Max RPM	Optimal RPM	Std. Pkg.	60	80	120
1/4"	1"	1/8"	25,000	20,000	100	<b>49490</b>	<b>48035</b>	<b>49491</b>
1/4"	1-1/2"	1/8"	25,000	20,000	100	<b>49100</b>	<b>49101</b>	<b>49102</b>
3/8"	1-1/2"	1/8"	24,000	16,000	100	<b>49103</b>	<b>47144</b>	<b>49104</b>
1/2"	1-1/2"	1/8"	18,000	12,000	100	<b>49105</b>	<b>49106</b>	<b>49107</b>
3/4"	1-1/2"	3/16"	12,000	8,000	100	49492	<b>49493</b>	49494

Ferrous  
  Non-Ferrous  
  Stainless  
  Exotic Alloys  
  Plastics  
  Composites

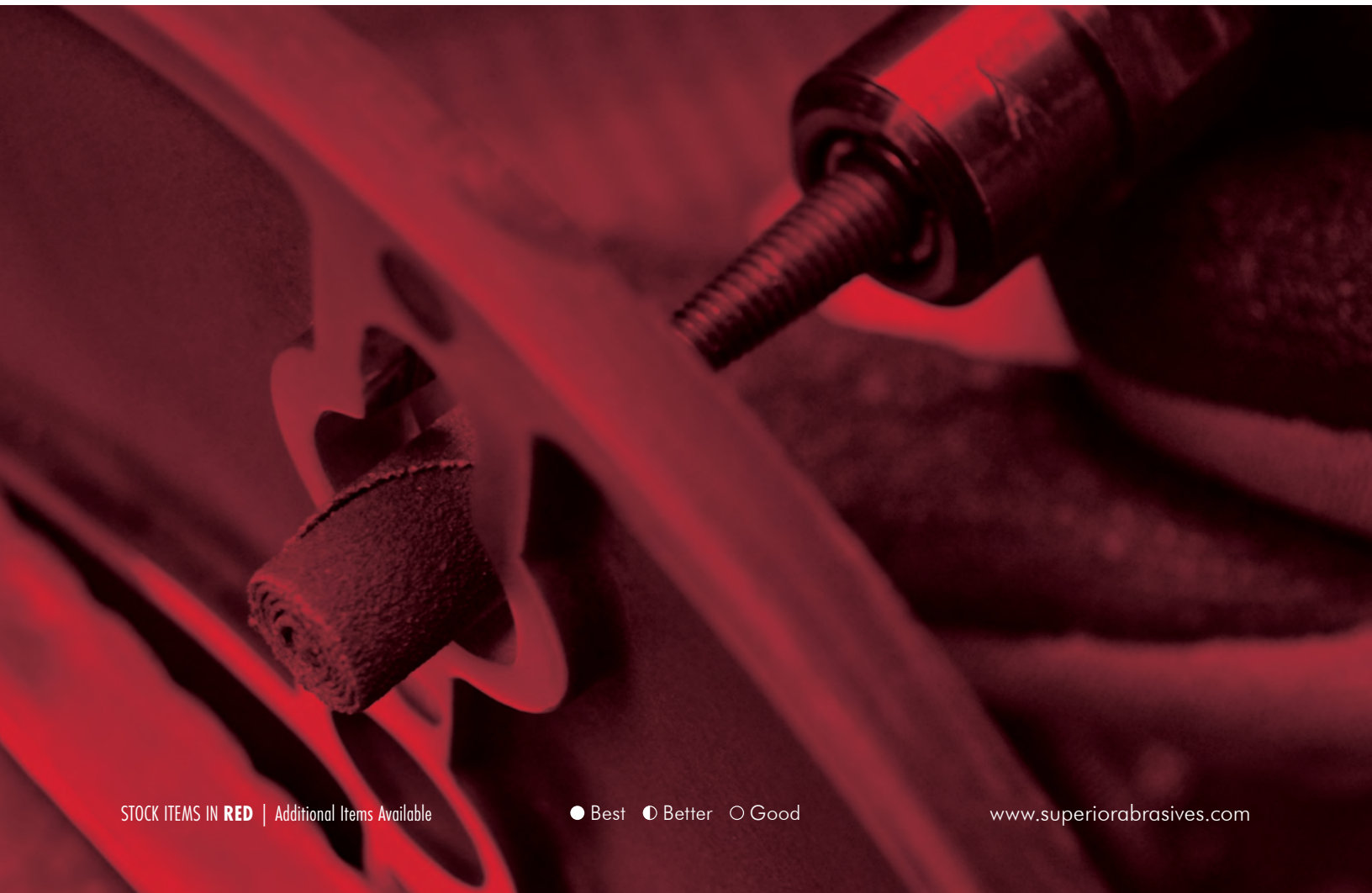

# SHUR-KUT® Coated

## **A<sub>o</sub>** ALUMINUM OXIDE STRAIGHT CARTRIDGE ROLLS

General purpose cutting action wears evenly and uniformly, producing a consistent cut on ferrous and non-ferrous metals. Use in straight holes or cylinders or around contoured parts.

- ▶ Remove or shape parts quickly
- ▶ Access intricate areas or small holes
- ▶ Deburr stamped parts

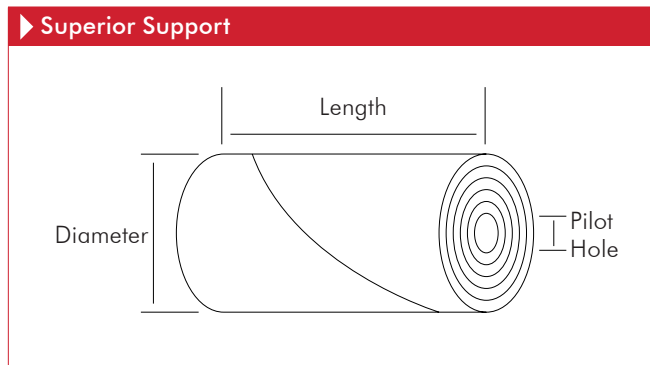

Diameter	Length	Pilot Hole	Max RPM	Optimal RPM	Std. Pkg.	36	60	80	100	120	180	240	320
3/16"	1"	3/32"	25,000	20,000	100	-	18965	<b>11860</b>	<b>18094</b>	<b>11861</b>	<b>18970</b>	18803	18805
1/4"	1"	1/8"	25,000	20,000	100	-	<b>11862</b>	<b>11863</b>	<b>11864</b>	<b>11865</b>	<b>11866</b>	<b>16984</b>	<b>16985</b>
1/4"	1-1/2"	1/8"	25,000	20,000	100	-	<b>11867</b>	<b>11868</b>	<b>11869</b>	<b>11870</b>	<b>11871</b>	<b>16719</b>	<b>16612</b>
1/4"	2"	1/8"	25,000	20,000	100	-	19721	<b>18666</b>	19722	19723	-	19727	55291
5/16"	1"	1/8"	23,000	18,500	100	-	19732	<b>16783</b>	-	<b>18874</b>	17016	32086	49876
5/16"	1-1/2"	1/8"	23,000	18,500	100	-	<b>19741</b>	<b>11872</b>	28232	<b>17068</b>	37515	18567	19745
3/8"	1"	1/8"	24,000	16,000	100	-	<b>11873</b>	<b>11874</b>	19750	<b>11875</b>	<b>11876</b>	<b>19752</b>	<b>17066</b>
3/8"	1-1/2"	1/8"	24,000	16,000	100	-	<b>11877</b>	<b>11878</b>	<b>11879</b>	<b>11880</b>	<b>11881</b>	<b>17160</b>	<b>16703</b>
3/8"	2"	1/8"	24,000	16,000	100	-	<b>21071</b>	<b>18665</b>	21851	23006	-	25636	40828
1/2"	1"	1/8"	18,000	12,000	100	-	<b>11882</b>	<b>11883</b>	<b>11884</b>	<b>11885</b>	<b>11886</b>	<b>18710</b>	<b>16986</b>
1/2"	1-1/2"	1/8"	18,000	12,000	100	<b>11887</b>	<b>11889</b>	<b>11890</b>	<b>11891</b>	<b>11892</b>	<b>11893</b>	<b>11894</b>	<b>11895</b>
1/2"	2"	1/8"	18,000	12,000	100	18716	<b>17167</b>	<b>16642</b>	-	<b>18475</b>	16747	54244	52465
5/8"	1-1/2"	3/16"	15,000	9,500	100	45889	<b>19799</b>	<b>19828</b>	-	19830	-	46224	-
3/4"	1"	3/16"	12,000	8,000	100	-	19852	19853	19854	17007	-	-	-
3/4"	1"	1/4"	12,000	8,000	100	-	17061	16655	16713	16716	-	16717	16718
3/4"	1-1/2"	3/16"	12,000	8,000	100	19878	<b>16069</b>	<b>16704</b>	19880	19881	49284	19885	-
3/4"	1-1/2"	1/4"	12,000	8,000	100	18811	<b>11896</b>	<b>11897</b>	54042	11898	19889	16731	16732
3/4"	2"	1/4"	12,000	8,000	100	-	11899	11900	-	17120	16646	54408	54053
1"	1-1/2"	1/4"	9,000	6,000	100	16165	<b>17006</b>	<b>18604</b>	-	18946	53501	53987	-
1"	2"	1/4"	9,000	6,000	100	18347	<b>11901</b>	<b>11902</b>	16981	11903	-	52193	19977

● Ferrous ● Non-Ferrous ● Stainless ● Exotic Alloys ○ Plastics ○ Composites



## Ao ALUMINUM OXIDE FULL TAPERED CARTRIDGE ROLLS

Tapered design provides more access and pointed control in concave areas or inside corners. Grind and follow acute seams and welds as the layers wear away to reveal fresh cutting action.

- ▶ Remove or smooth inside corner welds
- ▶ Port and shape concave areas
- ▶ Navigate intricate cast parts



Diameter	Length	Pilot Hole	Max RPM	Optimal RPM	Std. Pkg.	60	80	100	120	180	240	320
3/8"	1"	1/8"	24,000	16,000	100	<b>11904</b>	<b>11905</b>	17139	<b>11906</b>	11907	18585	17165
3/8"	1-1/2"	1/8"	24,000	16,000	100	<b>11908</b>	<b>11909</b>	18808	<b>11910</b>	11911	16029	18850
1/2"	1"	1/8"	18,000	12,000	100	<b>11912</b>	<b>11913</b>	30123	<b>11914</b>	11915	30126	30127
1/2"	1-1/2"	1/8"	18,000	12,000	100	<b>11916</b>	<b>11917</b>	17001	<b>11918</b>	<b>11919</b>	<b>16987</b>	<b>16988</b>
1/2"	2"	1/8"	18,000	12,000	100	16751	<b>20099</b>	-	30091	16841	-	-
5/8"	1-1/2"	3/16"	15,000	9,500	100	38597	16615	55282	44891	-	47486	-
3/4"	1-1/2"	3/16"	12,000	8,000	100	<b>16993</b>	<b>16652</b>	-	16624	-	-	-
1"	1-1/2"	3/16"	9,000	6,000	100	30341	30342	-	42845	-	-	-

- Ferrous  
  Non-Ferrous  
  Stainless  
  Exotic Alloys  
  Plastics  
  Composites

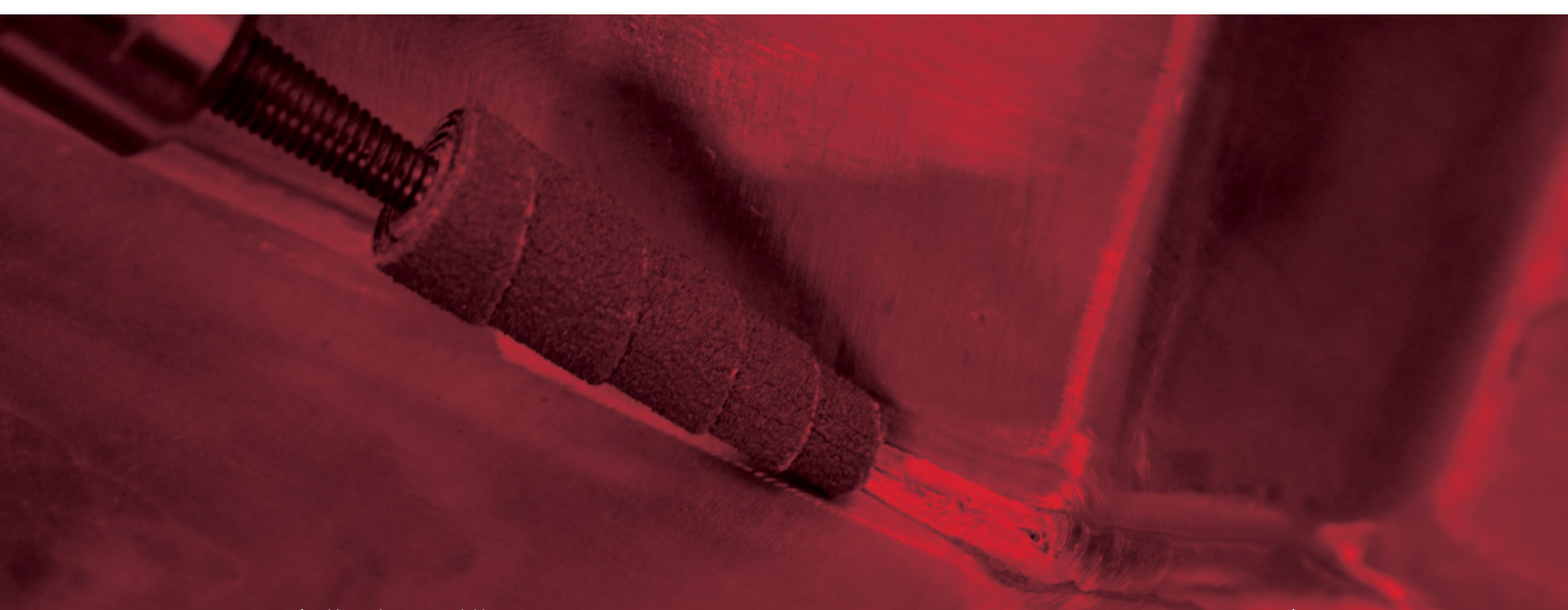

# SHUR-KUT® Coated

## ALUMINUM OXIDE CARTRIDGE ROLL TEST KIT

Several popular sizes and grits included with associated mandrels, providing everything you need in one convenient cartridge roll test kit.



Diameter	Length	Pilot Hole	Shape	80	120	Std. Pkg.	Part #
1/4"	1"	1/8"	Straight	16	16	1	<b>28802</b>
1/4"	1-1/2"	1/8"	Straight	9	12		
3/8"	1"	1/8"	Straight	6	6		
3/8"	1-1/2"	1/8"	Straight	12	12		
1/2"	1-1/2"	1/8"	Straight	8	8		
3/8"	1-1/2"	1/8"	Tapered	6	-		
1/2"	1-1/2"	1/8"	Tapered	9	-		
For 1" Cartridge Rolls			Mandrel	1			
For 1-1/2" Cartridge Rolls			Mandrel	1			

● Ferrous ● Non-Ferrous ● Stainless ● Exotic Alloys ○ Plastics ○ Composites

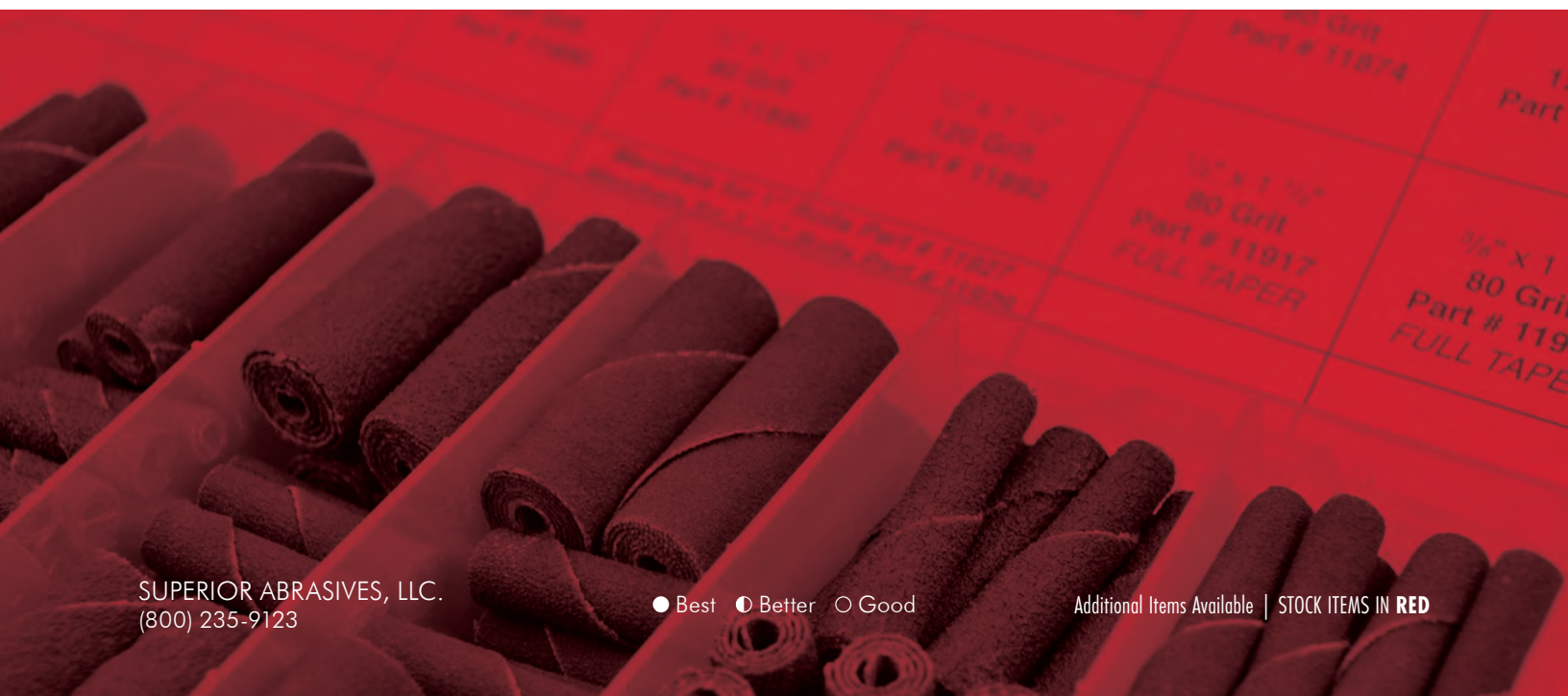



## CARTRIDGE ROLL MANDRELS

Used with portable die grinders, a tapered threaded shaft safely secures cartridge rolls to the mandrel. To ensure proper fitting, match the pilot dimensions.



**► Superior Support**

Roll Length	Proper Pilot Length
1"	3/4"
1-1/2"	1"
2"	1-1/2"

The diagram shows a cross-section of a mandrel with a wider 'Shank' section on the left and a narrower, tapered 'Pilot' section on the right. The pilot section is designed to fit into a cartridge roll.

Pilot Diameter	Pilot Length	Shank Diameter	Shank Length	Overall Length	Max RPM	Std. Pkg.	Part #
5/64"	1"	1/8"	1"	3"	60,000	1	<b>11920</b>
3/32"	3/4"	1/8"	1"	2-3/4"	60,000	1	<b>11921</b>
3/32"	3/4"	1/4"	1"	2-3/4"	28,000	1	<b>46934</b>
3/32"	1"	1/4"	1"	3"	28,000	1	46933
1/8"	1/2"	1/4"	1"	2-1/4"	28,000	1	<b>11926</b>
1/8"	3/4"	1/8"	1"	2-3/4"	60,000	1	<b>11923</b>
1/8"	3/4"	1/4"	1"	2-1/2"	28,000	1	<b>11927</b>
1/8"	3/4"	1/4"	4-1/2"	6"	28,000	1	<b>11928</b>
1/8"	1"	1/8"	1"	3"	60,000	1	<b>11924</b>
1/8"	1"	1/4"	1"	2-3/4"	28,000	1	<b>11929</b>
1/8"	1"	1/4"	4-1/4"	6"	28,000	1	<b>11930</b>
1/8"	1"	1/4"	6-1/4"	8"	28,000	1	<b>11931</b>
1/8"	1-1/2"	1/8"	1"	3-1/2"	60,000	1	11925
1/8"	1-1/2"	1/4"	1"	3-1/4"	28,000	1	<b>11932</b>
3/16"	3/4"	1/4"	1-1/4"	2-3/4"	28,000	1	<b>11934</b>
3/16"	1"	1/4"	1-1/4"	3"	28,000	1	<b>11935</b>
3/16"	1"	1/4"	4-1/4"	6"	28,000	1	<b>11936</b>
3/16"	1-1/2"	1/4"	1-1/4"	3-1/2"	28,000	1	<b>11937</b>
1/4"	3/4"	1/4"	1-1/4"	2-3/4"	28,000	1	<b>11939</b>
1/4"	1"	1/4"	1-1/4"	3"	28,000	1	<b>11940</b>
1/4"	1"	1/4"	4-1/4"	6"	28,000	1	<b>11941</b>
1/4"	1-1/2"	1/4"	1-1/4"	3-1/2"	28,000	1	<b>11942</b>

# SHUR-KUT® Coated

## Abrasive Caps

A rigid design and firm holder provide precision shaping and grinding on all types of metal. The seamless design of abrasive caps allows use of their entire surface area. Beneficial to fine detail work, the consistent edge radius upholds the grinding shape, creating a repeatable action with every replacement cap. Multiple shapes and sizes are available and provide a fitted tool for many unique workpieces and hard to access areas.

## Applications

- ▶ Repeatable grinding and shaping
- ▶ Mold and die repair
- ▶ Access small holes and channels
- ▶ Fine detail work on intricate parts

### ▶ Superior Support

Multiple styles available to precisely match existing surface shapes and contours.

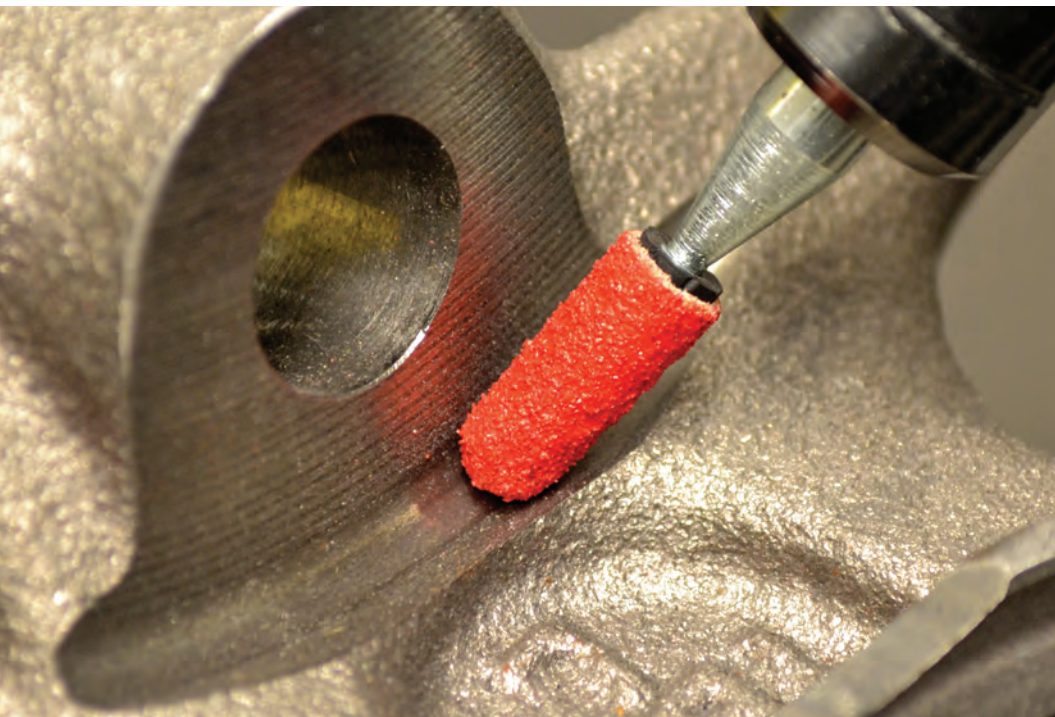
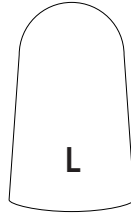
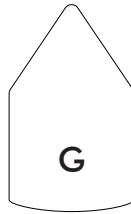
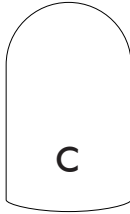





## CA CERAMIC CAPS

Self-sharpening grains continually produce fresh cutting points, reducing friction and prolonging cut rates. Reshape or blend corners without premature failure. Available with tapered or cylindrical radius end.

- ▶ Access narrow areas
- ▶ Precision shaping and grinding
- ▶ Rigid design withholds shape
- ▶ Shape or repair casting molds



Shape	Diameter	Length	Max RPM	Optimal RPM	Std. Pkg.	80	120
Shape C 	3/16"	7/16"	95,000	40,000	1	<b>53350</b>	<b>53351</b>
	9/32"	1/2"	65,000	30,000	1	<b>53356</b>	<b>53357</b>
	3/8"	5/8"	45,000	20,000	1	<b>53362</b>	<b>53363</b>
	1/2"	11/16"	35,000	16,000	1	<b>53368</b>	<b>53369</b>
	5/8"	1"	30,000	12,000	1	<b>53374</b>	<b>53375</b>
Shape L 	1/4"	5/8"	95,000	40,000	1	<b>53380</b>	<b>53381</b>
	7/16"	1"	40,000	20,000	1	<b>53386</b>	<b>53387</b>
	5/8"	1-1/4"	30,000	12,000	1	<b>53392</b>	<b>53393</b>
	27/32"	1-9/16"	20,000	9,000	1	<b>53398</b>	<b>53399</b>

Ferrous  
  Non-Ferrous  
  Stainless  
  Exotic Alloys  
  Plastics  
  Composites







## Ao ALUMINUM OXIDE CAPS

General purpose cutting action and durable use on ferrous, non-ferrous, stainless steel, alloys and non-metallics. Rigid design quickly removes stock and is precise and repeatable in shaping parts. Available with tapered, cylindrical or pointed cone end.

- ▶ Access narrow areas
- ▶ Precision shaping and grinding
- ▶ Rigid design retains shape
- ▶ Shape or repair casting molds



Shape	Diameter	Length	Max RPM	Optimal RPM	Std. Pkg.	60	80	150	280
Shape C 	3/16"	7/16"	95,000	40,000	50	-	<b>53347</b>	<b>53348</b>	<b>53349</b>
	9/32"	1/2"	65,000	30,000	50	<b>53353</b>	-	<b>53354</b>	<b>53355</b>
	3/8"	5/8"	45,000	20,000	50	<b>53359</b>	-	<b>53360</b>	<b>53361</b>
	1/2"	11/16"	35,000	16,000	50	<b>53365</b>	-	<b>53366</b>	<b>53367</b>
	5/8"	1"	30,000	12,000	50	<b>53371</b>	-	<b>53372</b>	<b>53373</b>
Shape G 	3/16"	7/16"	95,000	40,000	50	-	<b>53401</b>	<b>53402</b>	<b>53403</b>
	9/32"	1/2"	65,000	30,000	50	<b>53405</b>	-	<b>53406</b>	<b>53407</b>
	3/8"	5/8"	45,000	20,000	50	<b>53409</b>	-	<b>53410</b>	<b>53411</b>
	1/2"	11/16"	35,000	16,000	50	<b>53413</b>	-	<b>53414</b>	<b>53415</b>
	5/8"	1"	30,000	12,000	50	<b>53417</b>	-	<b>53418</b>	<b>53419</b>
Shape L 	1/4"	5/8"	95,000	40,000	50	-	<b>53377</b>	<b>53378</b>	<b>53379</b>
	7/16"	1"	40,000	20,000	50	<b>53383</b>	-	<b>53384</b>	<b>53385</b>
	5/8"	1-1/4"	30,000	12,000	50	<b>53389</b>	-	<b>53390</b>	<b>53391</b>
	27/32"	1-9/16"	20,000	9,000	50	<b>53395</b>	-	<b>53396</b>	<b>53397</b>

● Ferrous   ● Non-Ferrous   ○ Stainless   ○ Exotic Alloys   ● Plastics   ● Composites

## CAP HOLDERS



The precision form of cap holders secure caps in place by expanding during use.



### ► Superior Support

To assist with removal and replacement, raise and lower the used or worn cap while slightly twisting.



Shape	Diameter	Length	Shank	Max RPM	Std. Pkg.	Part #
Shape C 	3/16"	7/16"	1/8"	95,000	1	<b>53346</b>
	9/32"	1/2"	1/8"	65,000	1	<b>53352</b>
	3/8"	5/8"	1/8"	45,000	1	<b>53358</b>
	1/2"	11/16"	1/4"	35,000	1	<b>53364</b>
	5/8"	1"	1/4"	30,000	1	<b>53370</b>
Shape G 	3/16"	7/16"	1/8"	95,000	1	<b>53400</b>
	9/32"	1/2"	1/8"	65,000	1	<b>53404</b>
	3/8"	5/8"	1/8"	45,000	1	<b>53408</b>
	1/2"	11/16"	1/4"	35,000	1	<b>53412</b>
	5/8"	1"	1/4"	30,000	1	<b>53416</b>
Shape L 	1/4"	5/8"	1/4"	95,000	1	<b>53376</b>
	7/16"	1"	1/4"	40,000	1	<b>53382</b>
	5/8"	1-1/4"	1/4"	30,000	1	<b>53388</b>
	27/32"	1-9/16"	1/4"	20,000	1	<b>53394</b>

# SHUR-KUT® Coated

## Cones

Small diameter cones are designed to chamfer at precise angles. Easily used in holes and around edges for edge breaking or deburring. Chamfering and center lap cones are well suited for recessing holes to specified depths. Rigid cloth backing with tough and durable aluminum oxide grains retains its shape throughout use, ensuring consistent results.

## Applications

- ▶ Precisely recess holes
- ▶ Edge breaking and chamfering
- ▶ Deburring machined holes
- ▶ Use on stationary or small parts



## A<sub>0</sub> CHAMFERING CONES

Rapid 90° chamfering on stationary or handheld parts. Quick change mounting system for fast, tool-less changeout. Accurately and safely chamfer without damaging surrounding surfaces.

- ▶ Quickly chamfer holes or edges
- ▶ Use with multiple tools
- ▶ Molded backing upholds shape
- ▶ Quick change design



Base Diameter	Angle	Min ID	Max ID	Max RPM	Std. Pkg.	60	80	120	180
5/8"	90°	1/8"	1/2"	25,000	100	<b>12201</b>	<b>12202</b>	12203	12204
7/8"	90°	1/8"	3/4"	21,000	100	<b>12205</b>	<b>12206</b>	<b>12207</b>	12208

● Ferrous ● Non-Ferrous ● Stainless ● Exotic Alloys ○ Plastics ○ Composites

## CHAMFERING CONE HOLDERS

Base Diameter	Shank	Angle	Max RPM	Std. Pkg.	Part #
5/8"	1/4"	90°	10,000	1	<b>12209</b>
7/8"	1/4"	90°	8,800	1	<b>12210</b>



## A<sub>o</sub> CENTER LAP CONES



Durable cloth abrasive is precisely formed and mounted to a solid pointed holder. Tool-free locknut prevents cone slippage for continued performance against all types of metals. Used with center lapping machines and drill presses.

- ▶ Rigid cloth backing maintains shape
- ▶ Accurate 60° chamfer
- ▶ Precision holder reduces chatter
- ▶ Tool-free locknut for fast changeout

Base Diameter	Angle	Min ID	Max ID	Max RPM	Std. Pkg.	60	80	120	180
3/4"	60°	1/8"	5/8"	21,000	100	<b>12191</b>	<b>12192</b>	<b>12193</b>	<b>12194</b>
1-1/2"	60°	1/8"	1-3/8"	17,000	100	<b>12195</b>	<b>12196</b>	<b>12197</b>	<b>12198</b>

● Ferrous ● Non-Ferrous ● Stainless ● Exotic Alloys ○ Plastics ○ Composites

## CENTER LAP CONE HOLDERS



Base Diameter	Shank	Angle	Max RPM	Std. Pkg.	Part #
3/4"	1/2"	60°	10,000	1	<b>12199</b>
1-1/2"	1/2"	60°	8,800	1	<b>12200</b>

● Best ● Better ○ Good

[www.superiorabrasives.com](http://www.superiorabrasives.com)

STOCK ITEMS IN **RED** | Additional Items Available

# SHUR-KUT® Coated

## Spiral Bands

The solid, single layer design of spiral bands produces rapid material removal on curved or contoured parts. Used with a well-balanced rubber drum, bands are smooth in operation and do not chatter during use. With the firm combination of abrasive band and rubber drum, precise diameter grinding and finishing is achievable.

## Applications

- ▶ Fast and aggressive blending and removal
- ▶ Remove flash or burrs from small parts
- ▶ Precision diameter grinding
- ▶ Cast parting line removal

## A<sub>0</sub> SPIRAL BANDS



General purpose cutting action and durable use on ferrous, non-ferrous, stainless steel, alloys and non-metallics. Rigid design quickly removes stock and is precise in diameter grinding.

- ▶ Remove or shape parts quickly
- ▶ Navigate contoured surfaces easily
- ▶ Fast changeover with no tooling
- ▶ Parting line and flash removal
- ▶ Precise deburring and blending

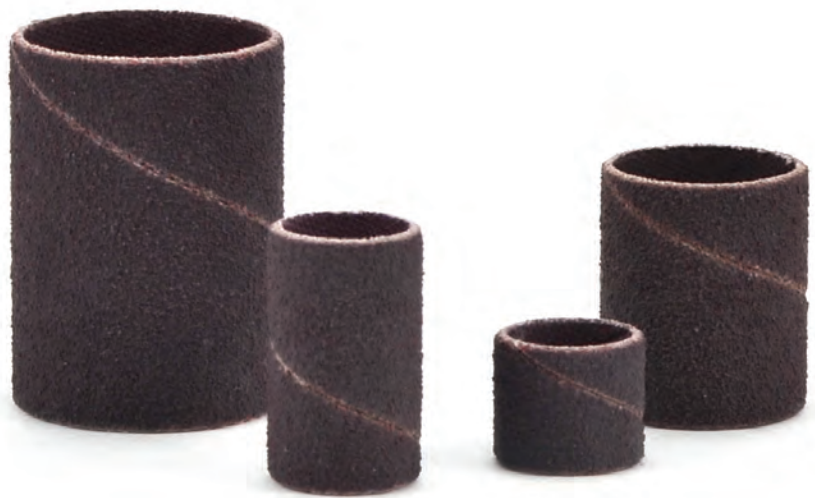

Diameter	Length	Max RPM	Std. Pkg.	36	60	80	120
1/2"	1/2"	30,000	100	52306	<b>11947</b>	<b>11948</b>	<b>11949</b>
1/2"	1"	20,000	100	<b>11950</b>	<b>11953</b>	<b>11954</b>	<b>11955</b>
3/4"	3/4"	24,000	100	-	18101	18882	19297
3/4"	1"	19,000	100	<b>11962</b>	<b>11965</b>	<b>11966</b>	<b>11967</b>
3/4"	2"	9,000	100	11974	11977	11978	19321
1"	1"	15,000	100	<b>11981</b>	<b>11984</b>	<b>11985</b>	<b>11986</b>
1"	1-1/2"	10,000	100	<b>11988</b>	11991	<b>11992</b>	11993
1-1/2"	1"	14,000	100	16765	18765	16683	49950
1-1/2"	1-1/2"	10,000	100	<b>12002</b>	<b>12005</b>	12006	12007
2"	1"	11,000	100	12016	12019	12020	12021
2"	1-1/2"	8,000	100	12023	12026	12027	12028
2"	2"	6,000	100	12030	<b>12033</b>	12034	12035
3"	3"	3,000	50	12051	12054	12055	12056

● Ferrous   ● Non-Ferrous   ● Stainless   ○ Exotic Alloys   ● Plastics   ● Composites

**RUBBER EXPANDING DRUMS**



For use with Spiral Bands, the balanced construction provides smooth operation for high speed, precision applications.



Diameter	Length	Shank	Max RPM	Std. Pkg.	Part #
1/4"	1/2"	1/8"	30,000	1	<b>12057</b>
3/8"	1/2"	1/8"	30,000	1	<b>12058</b>
1/2"	1/2"	1/8"	30,000	1	<b>12059</b>
1/2"	1/2"	1/4"	30,000	1	<b>12060</b>
1/2"	1"	1/4"	20,000	1	<b>12061</b>
1/2"	1-1/2"	1/4"	14,000	1	12062
1/2"	2"	1/4"	10,000	1	12063
3/4"	1"	1/4"	19,000	1	<b>12069</b>
3/4"	1-1/2"	1/4"	12,000	1	<b>12070</b>
3/4"	2"	1/4"	9,000	1	<b>12071</b>
1"	1"	1/4"	15,000	1	<b>12073</b>
1"	1-1/2"	1/4"	10,000	1	<b>12074</b>
1"	2"	1/4"	8,000	1	12075
1-1/2"	1"	1/4"	14,000	1	<b>12080</b>
1-1/2"	1-1/2"	1/4"	10,000	1	<b>12081</b>
2"	1"	1/4"	11,000	1	<b>12084</b>
2"	1-1/2"	1/4"	8,000	1	12085
2"	2"	1/4"	6,000	1	<b>12086</b>
3"	3"	3/8"	3,000	1	12090

# SHUR-KUT® Coated

## Pads

Mandrel mounted pads are available in cross or square construction, both providing specialized use. Durable layers of cloth abrasives allow fresh exposure of new grains as top layers are worn away, providing consistent performance and long life th

## Applications

- ▶ Inside diameter cleaning and deburring
- ▶ Clean or prep narrow channels
- ▶ Inside corner stock removal and weld shaping
- ▶ Tube finishing

## Ao CROSS PADS

Flexible fingers easily conform to inside diameters and tubes for cleaning, prep or finishing. Easily deburr or chamfer machined holes with the finesse of handheld tools. Self-centering for smooth, flush wall sanding.

- ▶ Propeller-like design keeps workpiece visible
- ▶ Flex and conform to holes without damage
- ▶ Quickly clean hydraulic cylinders
- ▶ Quick change mandrel design



### ▶ Superior Support

“Width” specifies the shortest dimension of the cross-fingers.

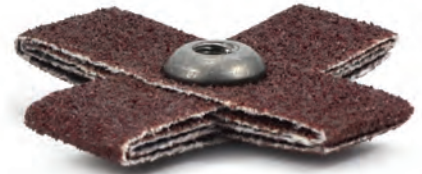

Length	Width	Ply	Eyelet	Max RPM	Std. Pkg.	60	80	120
1"	3/8"	8	3-48	25,000	100	21281	<b>21282</b>	21284
1-1/2"	1/2"	8	8-32	23,000	100	<b>13523</b>	<b>13524</b>	<b>13526</b>
2"	1/2"	8	8-32	23,000	100	<b>13545</b>	<b>13546</b>	13548
2"	3/4"	8	8-32	23,000	100	13567	13568	13570
2"	1"	8	1/4"-20	23,000	100	55729	13590	50480
2-1/2"	3/4"	8	1/4"-20	18,000	100	54881	35922	53699
3"	1"	8	1/4"-20	14,000	100	13743	<b>13744</b>	13746
4"	1"	8	1/4"-20	12,000	50	13787	13788	13790
4-1/2"	1-1/2"	8	1/4"-20	12,000	50	55730	54301	55731
5"	1-1/2"	8	1/4"-20	7,500	50	55521	55732	55522
6"	1-1/2"	8	1/4"-20	7,500	50	55416	54935	55733

- Ferrous
- Non-Ferrous
- Stainless
- Exotic Alloys
- Plastics
- Composites



# Ao SQUARE PADS

Corner strokes aggressively remove stock in channels, inside corners or hard to reach areas. Ideal for shaping, smoothing or removing inside corner welds, material layers wear away to expose fresh cutting surfaces, prolonging life.

- ▶ Sturdy design promotes aggressive removal
- ▶ Intermittent shape allows extra visibility
- ▶ Reach difficult channels and geometries
- ▶ Continually exposed layers for long life



Size	Thickness	Eyelet	Max RPM	Std. Pkg.	60	80	120
1-1/2"	3/8"	8-32	18,000	100	13998	13999	14001
1-1/2"	1/2"	1/4"-20	18,000	100	14009	14010	14012
1-1/2"	3/4"	1/4"-20	18,000	100	14020	14021	14023
2"	3/8"	1/4"-20	12,000	100	14042	14043	14045
2"	1/2"	1/4"-20	12,000	100	14053	14054	14056
3"	1/2"	1/4"-20	9,000	100	14097	14098	14100

● Ferrous   ● Non-Ferrous   ● Stainless   ● Exotic Alloys   ○ Plastics   ○ Composites

## EYELET MANDRELS



Overall Length	Shank Diameter	Fits Thread	Std. Pkg.	Part #
3"	1/4"	3-48	1	<b>21316</b>
3"	1/4"	8-32	1	<b>12218</b>
3"	1/4"	1/4"-20	1	<b>12219</b>
6"	1/4"	1/4"-20	1	<b>42815</b>

## MANDREL EXTENSIONS



Overall Length	Shank Diameter	Fits Thread	Std. Pkg.	Part #
4"	1/4"	1/4"-20	1	<b>39207</b>
6"	1/4"	1/4"-20	1	<b>39208</b>
8"	1/4"	1/4"-20	1	<b>39209</b>

# SHUR-KUT® Coated

## Rolls

Conveniently dispensed, tear-to-length rolls in common widths for several applications. Cloth backing provides durable wear and flexibility for extended use on edge or cylindrical parts. Commonly used for lathe parts shaping and sizing, finishing or polishing. Standard sizing and packaging for versatile maintenance and machine shop use.

## Applications

- ▶ Hand finishing tube or contoured parts
- ▶ General purpose hand finishing
- ▶ Lathe parts finishing and polishing
- ▶ Crankshaft and bearing polishing

## A<sub>o</sub> RESIN CLOTH SHOP & PRODUCTION ROLLS

Durable, flexible cloth backing conforms to cylindrical or contoured parts. Tear to usable length to accommodate various tasks and reduce waste. Up to 6" width for larger scale applications.

- ▶ Flexible with excellent grain retention
- ▶ Conform to small radii and fine contours
- ▶ Precision lathe grinding
- ▶ Durable backing for aggressive applications



Width	Length	Std. Pkg.	50J	60J	80J	100J	120J	150J	180J	220J	240J	320J	400J	500J	CROCUS
1"	50 Yds.	1	12106	<b>12107</b>	12108	<b>12109</b>	<b>12110</b>	<b>12111</b>	<b>12112</b>	<b>12113</b>	<b>12114</b>	<b>12115</b>	<b>12116</b>	<b>12117</b>	<b>40038</b>
1-1/2"	50 Yds.	1	<b>12118</b>	<b>12119</b>	<b>12120</b>	<b>12121</b>	<b>12122</b>	<b>12123</b>	<b>12124</b>	<b>12125</b>	<b>12126</b>	<b>12127</b>	<b>12128</b>	<b>12129</b>	<b>40039</b>
2"	50 Yds.	1	<b>12130</b>	<b>12131</b>	<b>12132</b>	<b>12133</b>	<b>12134</b>	<b>12135</b>	<b>12136</b>	<b>12137</b>	<b>12138</b>	<b>12139</b>	<b>12140</b>	<b>12141</b>	<b>40040</b>
3"	50 Yds.	1	48897	26395	<b>26870</b>	27142	<b>26461</b>	35157	35158	35159	<b>27595</b>	<b>39427</b>	27597	-	-
6"	50 Yds.	1	-	27135	27136	53496	27137	-	27138	-	27139	50346	52227	-	-

● Ferrous ● Non-Ferrous ● Stainless ○ Exotic Alloys ● Plastics ● Composites

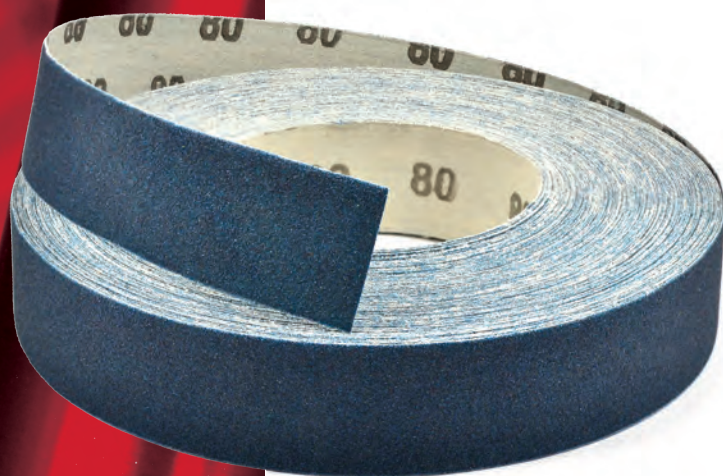

## Ao BLUE SHOP ROLLS



Flexible, blue aluminum oxide cloth rolls for shaping, cleaning, prep or finishing contoured parts. Tear to usable length to accommodate various tasks and reduce waste.

- ▶ Flexible, durable backing
- ▶ Smoothing and deburring
- ▶ Conform to small radii and fine contours

Width	Length	Std. Pkg.	60J	80J	100J	120J	150J	180J	240J
1"	50 Yds.	1	44951	<b>44952</b>	<b>44953</b>	<b>44954</b>	44955	<b>44956</b>	<b>44958</b>
1-1/2"	50 Yds.	1	<b>44959</b>	<b>44960</b>	44961	<b>44962</b>	<b>44963</b>	<b>44964</b>	<b>44966</b>
2"	50 Yds.	1	<b>44967</b>	<b>44968</b>	44969	<b>44970</b>	<b>44971</b>	<b>44972</b>	<b>44974</b>

● Ferrous ● Non-Ferrous ● Stainless ○ Exotic Alloys ● Plastics ● Composites

## Ao COST CONTROL SHOP ROLLS

Reduce waste with tear-to-length shops rolls, suited for hand or machine shaping, finishing or polishing. Cost effective option to Resin Cloth Shop Rolls.

- ▶ Flexible backing contours parts
- ▶ Lathe grinding and drum sanding
- ▶ Durable aluminum oxide grains



Width	Length	Std. Pkg.	60J	80J	100J	120J	180J	220J	240J	320J
1"	50 Yds.	1	26682	<b>26683</b>	26684	<b>26685</b>	<b>26687</b>	26688	<b>26689</b>	<b>26690</b>
1-1/2"	50 Yds.	1	<b>26694</b>	<b>26695</b>	26696	<b>26697</b>	<b>26699</b>	<b>26700</b>	<b>26701</b>	<b>26702</b>
2"	50 Yds.	1	<b>26726</b>	<b>26727</b>	<b>26728</b>	<b>26729</b>	<b>26731</b>	26732	<b>26733</b>	<b>26734</b>

● Ferrous ● Non-Ferrous ● Stainless ○ Exotic Alloys ● Plastics ● Composites

# SHUR-KUT® Coated

## Sheets

General purpose product form can be cut to size, folded, or used in full sheets for a variety of maintenance or machine shop applications. Durable cloth materials flex and conform to contours and cylindrical parts and withstand aggressive applications. Paper backings adapt to corners and acute geometries and can be wrapped around dowels for finishing small tubes or holes.

## Applications

- ▶ Cleaning, prep or finishing flat and contoured parts
- ▶ Polishing large or intricate parts
- ▶ Lathe parts finishing and polishing
- ▶ Blending or spot sanding
- ▶ Crankshaft and bearing polishing

## A<sub>o</sub> ALUMINUM OXIDE RESIN CLOTH SHEETS

Durable, flexible cloth backing and dense grains conform to cylindrical or contoured parts. Cut or tear to usable size to accommodate various tasks and reduce waste.

- ▶ Flexible with excellent grain retention
- ▶ Conform to small radii and fine contours
- ▶ Durable backing for aggressive applications
- ▶ Precision lathe and drum grinding



Width	Length	Std. Pkg.	40X	50X	60X	80J	100J	120J	150J	180J	220J	240J	320J	400J	500J	CROCUS
9"	11"	50 (*25)	<b>12145*</b>	<b>12146*</b>	<b>12147*</b>	<b>12148</b>	<b>12149</b>	<b>12150</b>	<b>12151</b>	<b>12152</b>	<b>12153</b>	<b>12154</b>	<b>12155</b>	<b>12156</b>	<b>12157</b>	<b>16130</b>

● Ferrous ● Non-Ferrous ● Stainless ● Exotic Alloys ● Plastics ● Composites



## A<sub>o</sub> ALUMINUM OXIDE RESIN CLOTH STIK-ON STRIPS

Pre-cut cloth strips with PSA backing allows temporary adhesion to stationary or handheld sanding blocks for delicate shaping, cleaning or finishing. Narrow width to access channels or hard to reach areas.

- ▶ Strong, removable adhesive
- ▶ Narrow strips for limited access
- ▶ Durable backing for aggressive applications

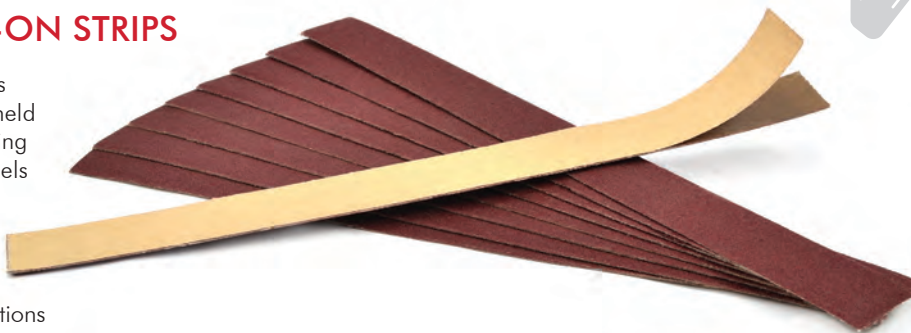

Width	Length	Std. Pkg.	80	100	120	150	180	240	320
1"	11"	100	<b>12227</b>	<b>12228</b>	<b>12229</b>	12230	<b>12231</b>	<b>12232</b>	<b>12233</b>

● Ferrous ● Non-Ferrous ● Stainless ● Exotic Alloys ● Plastics ● Composites

## E<sub>M</sub> EMERY CLOTH SHEETS

Flexible cloth backing with self-sharpening, fine grained abrasives. Used for final sizing and fitting of critical components where excess material removal is not necessary.

- ▶ Sharp fractures produce fine cuts
- ▶ Minimal surface removal for critical or sensitive applications
- ▶ Delicate rust removal



Width	Length	Std. Pkg.	CRS	MED	FINE
9"	11"	50 (*25)	<b>12174*</b>	<b>12175</b>	<b>12176</b>

● Ferrous ● Non-Ferrous ● Stainless ● Exotic Alloys ● Plastics ● Composites

## S<sub>C</sub> SILICON CARBIDE WATERPROOF PAPER SHEETS

Silicon carbide grains provide a sharp, fine cut. Thin, paper backing conforms to undulations and variable contours. Use with water or lubricants for much finer finishing and polishing.

- ▶ Sharper grains produce brighter and finer scratch patterns
- ▶ Cut and polish non-ferrous metals
- ▶ Use wet for finer polishing



Width	Length	Std. Pkg.	80C	100C	120C	150C	180C	220A	240A	320A	400A	500A	600A	1000	1500
9"	11"	50	<b>12158</b>	<b>21306</b>	<b>12159</b>	<b>18343</b>	<b>12160</b>	<b>12161</b>	<b>12162</b>	<b>12163</b>	<b>12164</b>	<b>12165</b>	<b>12166</b>	<b>40208</b>	<b>41347</b>

● Ferrous ● Non-Ferrous ● Stainless ● Exotic Alloys ● Plastics ● Composites

<b>10101</b> .....	114	<b>10174</b> .....	115	<b>10531</b> .....	40	<b>10583</b> .....	26	10647.....	33	10705.....	110
<b>10102</b> .....	114	<b>10175</b> .....	115	<b>10532</b> .....	40	<b>10583B</b> .....	26	10648.....	33	10706.....	110
<b>10103</b> .....	114	<b>10177</b> .....	115	10533.....	40	<b>10584</b> .....	26	10649.....	33	10735.....	110
<b>10104</b> .....	114	<b>10178</b> .....	115	<b>10540</b> .....	68, 74	<b>10584B</b> .....	26	<b>10650</b> .....	33	10737.....	110
<b>10105</b> .....	114	<b>10179</b> .....	115	10541.....	22	<b>10585</b> .....	26	10651.....	33	10744.....	110
<b>10106</b> .....	114	<b>10184</b> .....	115	<b>10541B</b> .....	22	<b>10585B</b> .....	26	10658.....	33	10745.....	110
<b>10107</b> .....	114	<b>10185</b> .....	115	<b>10542</b> .....	22	<b>10589</b> .....	26	10659.....	33	10746.....	110
<b>10108</b> .....	114	<b>10186</b> .....	115	<b>10542B</b> .....	22	<b>10589B</b> .....	26	10660.....	33	10747.....	110
<b>10109</b> .....	114	10192.....	115	<b>10543</b> .....	22	<b>10590</b> .....	26	10661.....	33	10748.....	110
<b>10110</b> .....	114	10193.....	115	<b>10543B</b> .....	22	<b>10590B</b> .....	26	10662.....	33	10749.....	110
<b>10114</b> .....	114	10196.....	115	<b>10544</b> .....	22	<b>10591</b> .....	26	10663.....	33	10750.....	110
<b>10115</b> .....	114	<b>10197</b> .....	115	<b>10544B</b> .....	22	10591B.....	26	<b>10664</b> .....	33	10753.....	110
<b>10116</b> .....	114	10198.....	115	<b>10545</b> .....	22	<b>10598</b> .....	27	<b>10665</b> .....	33	10754.....	110
<b>10117</b> .....	114	<b>10203</b> .....	115	<b>10545B</b> .....	22	<b>10599</b> .....	27	<b>10666</b> .....	33	10755.....	110
<b>10118</b> .....	114	10204.....	115	<b>10546</b> .....	22	<b>10600</b> .....	27	10667.....	110	<b>10756</b> .....	110
<b>10119</b> .....	114	<b>10205</b> .....	115	<b>10546B</b> .....	22	<b>10601</b> .....	27	10668.....	110	10757.....	110
<b>10120</b> .....	114	<b>10208</b> .....	115	<b>10547</b> .....	22	<b>10602</b> .....	27	10669.....	110	10758.....	110
<b>10124</b> .....	114	10391.....	45, 59, 69, 117	<b>10547B</b> .....	22	<b>10605</b> .....	27	<b>10670</b> .....	110	10759.....	110
<b>10125</b> .....	114	<b>10392</b> .....	45, 59, 69, 117	<b>10548</b> .....	22	<b>10607</b> .....	33	<b>10671</b> .....	110	10760.....	110
<b>10126</b> .....	114	<b>10393</b> .....	45, 59, 69, 117	<b>10548B</b> .....	22	<b>10608</b> .....	33	10672.....	110	10762.....	110
<b>10127</b> .....	114	<b>10426</b> .....	45	<b>10549</b> .....	22	<b>10609</b> .....	33	10673.....	110	10763.....	110
<b>10128</b> .....	114	<b>10427</b> .....	45	<b>10549B</b> .....	22	<b>10610</b> .....	33	10674.....	110	10764.....	110
<b>10129</b> .....	114	<b>10428</b> .....	45	<b>10550</b> .....	22	<b>10611</b> .....	33	10675.....	110	10765.....	110
<b>10130</b> .....	114	<b>10429</b> .....	45	<b>10550B</b> .....	22	<b>10612</b> .....	33	10676.....	110	10766.....	110
<b>10131</b> .....	114	<b>10430</b> .....	45	<b>10551</b> .....	22	<b>10613</b> .....	33	10677.....	110	10767.....	110
10132.....	114	<b>10431</b> .....	45	<b>10551B</b> .....	22	<b>10614</b> .....	33	<b>10678</b> .....	110	10768.....	110
<b>10136</b> .....	114	<b>10459</b> .....	46	<b>10552</b> .....	22	<b>10615</b> .....	33	<b>10679</b> .....	110	10771.....	110
<b>10137</b> .....	114	<b>10460</b> .....	46	<b>10552B</b> .....	22	<b>10616</b> .....	33	10680.....	110	10772.....	110
<b>10138</b> .....	114	<b>10461</b> .....	46	<b>10553</b> .....	22	<b>10617</b> .....	33	<b>10681</b> .....	110	10773.....	110
10139.....	114	<b>10462</b> .....	46	<b>10553B</b> .....	22	<b>10618</b> .....	33	10682.....	110	10774.....	110
<b>10142</b> .....	114	<b>10463</b> .....	46	<b>10554</b> .....	22	<b>10622</b> .....	33	10683.....	110	10775.....	110
<b>10143</b> .....	114	<b>10464</b> .....	46	<b>10554B</b> .....	22	<b>10623</b> .....	33	<b>10684</b> .....	110	10776.....	110
<b>10144</b> .....	114	<b>10465</b> .....	46	<b>10555</b> .....	22	<b>10624</b> .....	33	10685.....	110	10777.....	110
<b>10148</b> .....	114	<b>10466</b> .....	46	<b>10555B</b> .....	22	<b>10625</b> .....	33	<b>10686</b> .....	110	10778.....	110
<b>10149</b> .....	114	<b>10467</b> .....	44	<b>10556</b> .....	22	<b>10626</b> .....	33	<b>10687</b> .....	110	10780.....	110
<b>10150</b> .....	114	<b>10468</b> .....	44	<b>10556B</b> .....	22	<b>10627</b> .....	33	10688.....	110	10781.....	110
<b>10151</b> .....	114	<b>10469</b> .....	44	<b>10557</b> .....	22	<b>10628</b> .....	33	<b>10689</b> .....	110	10782.....	110
<b>10152</b> .....	114	<b>10470</b> .....	44	<b>10557B</b> .....	22	<b>10629</b> .....	33	10690.....	110	<b>10783</b> .....	110
<b>10153</b> .....	114	<b>10471</b> .....	44	<b>10558</b> .....	22	<b>10630</b> .....	33	10691.....	110	<b>10784</b> .....	110
<b>10157</b> .....	114	<b>10472</b> .....	44	<b>10558B</b> .....	22	10631.....	33	<b>10692</b> .....	110	10785.....	110
<b>10158</b> .....	114	<b>10473</b> .....	52	10577.....	26	10632.....	33	10693.....	110	10786.....	110
<b>10159</b> .....	114	<b>10474</b> .....	52	<b>10577B</b> .....	26	10633.....	33	<b>10694</b> .....	110	10787.....	110
<b>10160</b> .....	115	<b>10475</b> .....	52	10578.....	26	10634.....	33	<b>10695</b> .....	110	10789.....	110
<b>10161</b> .....	115	<b>10476</b> .....	52	<b>10578B</b> .....	26	<b>10635</b> .....	33	10696.....	110	10790.....	110
<b>10162</b> .....	115	<b>10511</b> .....	39	10579.....	26	<b>10636</b> .....	33	<b>10697</b> .....	110	10791.....	110
<b>10163</b> .....	115	<b>10512</b> .....	39	<b>10579B</b> .....	26	10637.....	33	10698.....	110	10792.....	110
<b>10164</b> .....	115	<b>10513</b> .....	39	<b>10580</b> .....	26	10638.....	33	10699.....	110	10793.....	110
<b>10165</b> .....	115	<b>10514</b> .....	39	<b>10580B</b> .....	26	10639.....	33	10700.....	110	10794.....	110
<b>10167</b> .....	115	10515.....	39	<b>10581</b> .....	26	10643.....	33	10701.....	110	10795.....	110
<b>10168</b> .....	115	<b>10516</b> .....	39	<b>10581B</b> .....	26	<b>10644</b> .....	33	<b>10702</b> .....	110	10796.....	110
<b>10169</b> .....	115	10517.....	39	<b>10582</b> .....	26	10645.....	33	<b>10703</b> .....	110	10807.....	110
<b>10173</b> .....	115	10518.....	39	<b>10582B</b> .....	26	10646.....	33	10704.....	110	10808.....	110

10809	110	10888	110	10966	110	<b>11158</b>	88	<b>11232</b>	89	11409	94
10810	110	10889	110	10967	110	<b>11159</b>	88	<b>11233</b>	89	<b>11410</b>	94
10811	110	10890	110	11039	110	<b>11161</b>	88	<b>11234</b>	89	<b>11411</b>	94
10812	110	10891	110	<b>11087</b>	89	<b>11162</b>	88	<b>11235</b>	89	<b>11412</b>	94
10813	110	10892	110	11088	89	11163	88	<b>11236</b>	89	<b>11413</b>	94
10814	110	10893	110	11089	89	<b>11164</b>	88	<b>11258</b>	88	<b>11414</b>	94
10816	110	10894	110	<b>11090</b>	89	<b>11165</b>	88	11259	88	<b>11416</b>	94
10817	110	10895	110	<b>11091</b>	89	<b>11166</b>	88	<b>11260</b>	88	<b>11417</b>	94
10818	110	10897	110	<b>11092</b>	89	<b>11168</b>	88	<b>11261</b>	88	<b>11418</b>	94
10819	110	10898	110	<b>11093</b>	89	11169	23, 91	<b>11262</b>	88	11419	94
10820	110	10899	110	11095	89	<b>11170</b>	23, 91	<b>11264</b>	88	<b>11420</b>	94
10821	110	10900	110	11096	89	<b>11171</b>	23, 91	<b>11265</b>	88	11421	94
10822	110	10901	110	11097	89	<b>11172</b>	23, 91	11266	88	11422	94
10825	110	10902	110	11098	89	<b>11173</b>	23, 39, 91	11267	88	<b>11423</b>	94
10826	110	10903	110	<b>11099</b>	89	<b>11174</b>	23, 91	<b>11268</b>	88	<b>11424</b>	94
10827	110	10904	110	<b>11100</b>	89	<b>11175</b>	23, 91	<b>11269</b>	88	<b>11425</b>	94
10828	110	10906	110	<b>11101</b>	89	<b>11176</b>	23, 39, 91	<b>11271</b>	88	<b>11426</b>	94
10829	110	10907	110	<b>11102</b>	89	<b>11177</b>	23, 91	<b>11273</b>	23, 91	<b>11428</b>	94
10830	110	10908	110	<b>11103</b>	89	11178	23, 91	<b>11274</b>	23, 91	<b>11429</b>	94
10831	110	10909	110	<b>11104</b>	89	<b>11193</b>	89	<b>11275</b>	23, 39, 69, 77, 91, 103	<b>11430</b>	94
10832	110	10910	110	<b>11105</b>	89	<b>11194</b>	89	<b>11276</b>	23, 39, 69, 77, 91, 103	11431	94
10834	110	10911	110	11106	89	<b>11196</b>	89	11376	94	11432	94
10835	110	10912	110	<b>11107</b>	89	11198	89	11377	94	11433	94
10836	110	10915	110	<b>11108</b>	89	11199	89	11378	94	11434	94
10837	110	10916	110	11109	89	11201	89	<b>11379</b>	94	11435	94
10838	110	10917	110	<b>11110</b>	89	<b>11202</b>	89	11380	94	<b>11436</b>	94
10839	110	10918	110	<b>11111</b>	89	11203	89	11382	94	<b>11437</b>	94
10840	110	10919	110	<b>11112</b>	89	<b>11204</b>	89	11383	94	11438	94
10841	110	10920	110	<b>11113</b>	89	<b>11205</b>	89	11384	94	11440	94
10843	110	10921	110	<b>11114</b>	89	<b>11206</b>	89	11385	94	11441	94
10844	110	10922	110	<b>11115</b>	89	11207	89	11386	94	11442	94
10845	110	10924	110	<b>11116</b>	89	<b>11208</b>	89	11387	94	11443	94
10846	110	10925	110	<b>11117</b>	89	<b>11210</b>	89	11389	94	<b>11444</b>	94
10847	110	10926	110	<b>11118</b>	89	11211	89	11390	94	<b>11445</b>	94
10848	110	10927	110	<b>11119</b>	89	<b>11213</b>	89	<b>11391</b>	94	<b>11446</b>	94
10849	110	10928	110	<b>11120</b>	89	<b>11214</b>	89	<b>11392</b>	94	<b>11447</b>	94
10850	110	10929	110	<b>11121</b>	89	<b>11215</b>	89	<b>11393</b>	94	<b>11448</b>	94
10870	110	10930	110	<b>11122</b>	89	<b>11216</b>	89	11394	94	<b>11449</b>	94
10871	110	10933	110	<b>11123</b>	89	<b>11217</b>	89	11396	94	<b>11450</b>	94
10872	110	10934	110	<b>11124</b>	89	<b>11218</b>	89	11397	94	<b>11452</b>	94
10873	110	10935	110	<b>11125</b>	89	<b>11219</b>	89	11398	94	<b>11453</b>	94
10874	110	10936	110	<b>11126</b>	89	<b>11220</b>	89	11399	94	11454	94
10875	110	10937	110	<b>11127</b>	89	<b>11222</b>	89	11400	94	11455	94
10876	110	10938	110	<b>11128</b>	89	<b>11223</b>	89	11401	94	<b>11456</b>	94
10877	110	10939	110	<b>11129</b>	89	<b>11224</b>	89	11402	94	<b>11457</b>	94
10879	110	10940	110	<b>11130</b>	89	<b>11225</b>	89	11404	94	<b>11458</b>	94
10880	110	10960	110	<b>11131</b>	89	<b>11226</b>	89	11406	94	<b>11459</b>	94
10881	110	10961	110	<b>11132</b>	89	<b>11227</b>	89	11407	94	<b>11460</b>	94
10882	110	10962	110	<b>11133</b>	89	<b>11228</b>	89	11408	94	<b>11461</b>	94
10883	110	10963	110	<b>11155</b>	88	<b>11229</b>	89			<b>11462</b>	94
10884	110	10964	110	11156	88	<b>11230</b>	89			<b>11464</b>	94
10886	110	10965	110	<b>11157</b>	88	<b>11231</b>	89			<b>11465</b>	94

11466	94	11547	94	<b>11729</b>	106	<b>11879</b>	122	<b>11934</b>	125	<b>12059</b>	133
11476	94	11548	94	<b>11730</b>	106	<b>11880</b>	122	<b>11935</b>	125	<b>12060</b>	133
<b>11477</b>	94	11549	94	<b>11732</b>	106	<b>11881</b>	122	<b>11936</b>	125	<b>12061</b>	133
11478	94	11551	94	<b>11734</b>	106	<b>11882</b>	122	<b>11937</b>	125	12062	133
11479	94	<b>11552</b>	94	<b>11735</b>	106	<b>11883</b>	122	<b>11939</b>	125	12063	133
<b>11480</b>	94	<b>11553</b>	94	11736	106	<b>11884</b>	122	<b>11940</b>	125	<b>12069</b>	133
<b>11481</b>	94	<b>11554</b>	94	<b>11737</b>	106	<b>11885</b>	122	<b>11941</b>	125	<b>12070</b>	133
11482	94	<b>11555</b>	94	<b>11738</b>	106	<b>11886</b>	122	<b>11942</b>	125	<b>12071</b>	133
<b>11483</b>	94	<b>11556</b>	94	11740	106	<b>11887</b>	122	<b>11947</b>	132	<b>12073</b>	133
11484	94	11557	94	11748	105	<b>11889</b>	122	<b>11948</b>	132	<b>12074</b>	133
11485	94	11558	94	<b>11749</b>	105	<b>11890</b>	122	<b>11949</b>	132	12075	133
<b>11486</b>	94	11559	94	<b>11750</b>	105	<b>11891</b>	122	<b>11950</b>	132	<b>12080</b>	133
11487	94	11560	94	<b>11751</b>	105	<b>11892</b>	122	<b>11953</b>	132	<b>12081</b>	133
11488	94	<b>11561</b>	94	<b>11752</b>	105	<b>11893</b>	122	<b>11954</b>	132	<b>12084</b>	133
<b>11489</b>	94	<b>11562</b>	94	<b>11753</b>	105	<b>11894</b>	122	<b>11955</b>	132	12085	133
<b>11490</b>	94	11563	94	<b>11754</b>	105	<b>11895</b>	122	<b>11962</b>	132	<b>12086</b>	133
<b>11491</b>	94	11564	94	<b>11755</b>	105	<b>11896</b>	122	<b>11965</b>	132	12090	133
<b>11492</b>	94	11565	94	11756	105	<b>11897</b>	122	<b>11966</b>	132	12106	136
11493	94	11566	94	<b>11757</b>	105	11898	122	<b>11967</b>	132	<b>12107</b>	136
11494	94	11567	94	<b>11758</b>	105	11899	122	11974	132	12108	136
<b>11495</b>	94	11568	94	<b>11759</b>	105	11900	122	11977	132	<b>12109</b>	136
11496	94	<b>11685</b>	97	<b>11760</b>	105	<b>11901</b>	122	11978	132	<b>12110</b>	136
11497	94	<b>11687</b>	97	<b>11761</b>	105	<b>11902</b>	122	<b>11981</b>	132	<b>12111</b>	136
<b>11498</b>	94	<b>11688</b>	97	11762	105	11903	122	<b>11984</b>	132	<b>12112</b>	136
<b>11499</b>	94	<b>11689</b>	97	<b>11823</b>	100	<b>11904</b>	123	<b>11985</b>	132	<b>12113</b>	136
<b>11500</b>	94	<b>11692</b>	97	<b>11824</b>	100	<b>11905</b>	123	<b>11986</b>	132	<b>12114</b>	136
<b>11501</b>	94	<b>11693</b>	97	<b>11847</b>	29, 107	<b>11906</b>	123	<b>11988</b>	132	<b>12115</b>	136
11502	94	<b>11695</b>	97	<b>11850</b>	29, 107	11907	123	11991	132	<b>12116</b>	136
11503	94	<b>11697</b>	97	11852	107	<b>11908</b>	123	<b>11992</b>	132	<b>12117</b>	136
<b>11504</b>	94	<b>11698</b>	97	<b>11853</b>	107	<b>11909</b>	123	11993	132	<b>12118</b>	136
<b>11505</b>	94	<b>11701</b>	95	<b>11854</b>	107	<b>11910</b>	123	<b>12002</b>	132	<b>12119</b>	136
<b>11506</b>	94	<b>11702</b>	95	<b>11858</b>	29, 107	11911	123	<b>12005</b>	132	<b>12120</b>	136
<b>11507</b>	94	<b>11703</b>	95	<b>11859</b>	29, 107	<b>11912</b>	123	12006	132	<b>12121</b>	136
<b>11508</b>	94	<b>11704</b>	95	<b>11860</b>	122	<b>11913</b>	123	12007	132	<b>12122</b>	136
<b>11509</b>	94	<b>11705</b>	95	<b>11861</b>	122	<b>11914</b>	123	12016	132	<b>12123</b>	136
<b>11510</b>	94	<b>11706</b>	95	<b>11862</b>	122	11915	123	12019	132	<b>12124</b>	136
<b>11512</b>	94	<b>11707</b>	95	<b>11863</b>	122	<b>11916</b>	123	12020	132	<b>12125</b>	136
11513	94	<b>11708</b>	95	<b>11864</b>	122	<b>11917</b>	123	12021	132	<b>12126</b>	136
<b>11514</b>	94	<b>11709</b>	95	<b>11865</b>	122	<b>11918</b>	123	12023	132	<b>12127</b>	136
11533	94	11710	95	<b>11866</b>	122	<b>11919</b>	123	12026	132	<b>12128</b>	136
<b>11534</b>	94	11711	95	<b>11867</b>	122	<b>11920</b>	125	12027	132	<b>12129</b>	136
11535	94	<b>11715</b>	97	<b>11868</b>	122	<b>11921</b>	125	12028	132	<b>12130</b>	136
11536	94	<b>11716</b>	97	<b>11869</b>	122	<b>11923</b>	125	12030	132	<b>12131</b>	136
11537	94	<b>11718</b>	106	<b>11870</b>	122	<b>11924</b>	125	<b>12033</b>	132	<b>12132</b>	136
<b>11538</b>	94	<b>11719</b>	106	<b>11871</b>	122	11925	125	12034	132	<b>12133</b>	136
11539	94	<b>11720</b>	106	<b>11872</b>	122	<b>11926</b>	125	12035	132	<b>12134</b>	136
11540	94	<b>11721</b>	106	<b>11873</b>	122	<b>11927</b>	125	12051	132	<b>12135</b>	136
11542	94	<b>11722</b>	106	<b>11874</b>	122	<b>11928</b>	125	12054	132	<b>12136</b>	136
11543	94	<b>11724</b>	106	<b>11875</b>	122	<b>11929</b>	125	12055	132	<b>12137</b>	136
11544	94	<b>11726</b>	106	<b>11876</b>	122	<b>11930</b>	125	12056	132	<b>12138</b>	136
11545	94	<b>11727</b>	106	<b>11877</b>	122	<b>11931</b>	125	<b>12057</b>	133	<b>12139</b>	136
11546	94	<b>11728</b>	106	<b>11878</b>	122	<b>11932</b>	125	<b>12058</b>	133	<b>12140</b>	136



12141	136	12214	68	14384	110	16952	114	17508	93	19722	122
12142	107	12215	68	14385	110	16955	94	17509	93	19723	122
12143	107	12216	74	14386	110	16980	87	17511	93	19727	122
12144	107	12218	135	14387	110	16981	122	18004	94	19732	122
12145	138	12219	31, 51, 135	14388	110	16984	122	18059	87	19741	122
12146	138	12220	68	14389	110	16985	122	18094	122	19745	122
12147	138	12221	68	14390	110	16986	122	18101	132	19750	122
12148	138	12222	68	14392	110	16987	123	18154	87	19752	122
12149	138	12223	68	16029	123	16988	123	18157	87	19799	122
12150	138	12224	68	16037	114	16993	123	18166	87	19828	122
12151	138	12225	68	16056	93	17001	123	18216	87	19830	122
12152	138	12227	139	16069	122	17006	122	18217	87	19852	122
12153	138	12228	139	16095	94	17007	122	18232	87	19853	122
12154	138	12229	139	16108	93	17016	122	18343	139	19854	122
12155	138	12230	139	16120	40	17061	122	18347	122	19878	122
12156	138	12231	139	16130	138	17066	122	18353	22	19880	122
12157	138	12232	139	16165	122	17068	122	18353B	22	19881	122
12158	139	12233	139	16283	114	17116	114	18354	22	19885	122
12159	139	13523	134	16293	114	17120	122	18354B	22	19889	122
12160	139	13524	134	16612	122	17124	40	18434	33	19977	122
12161	139	13526	134	16615	123	17127	93	18435	33	20099	123
12162	139	13545	134	16624	123	17139	123	18445	114	20977	110
12163	139	13546	134	16642	122	17150	111	18475	122	21012	93
12164	139	13548	134	16646	122	17151	111	18508	94	21013	93
12165	139	13567	134	16652	123	17152	93	18509	94	21071	122
12166	139	13568	134	16655	122	17154	93	18567	122	21150	93
12174	139	13570	134	16683	132	17160	122	18585	123	21151	93
12175	139	13590	134	16685	94	17165	123	18593	114	21153	93
12176	139	13743	134	16703	122	17167	122	18604	122	21176	93
12191	131	13744	134	16704	122	17218	119	18665	122	21177	93
12192	131	13746	134	16713	122	17219	119	18666	122	21281	134
12193	131	13787	134	16716	122	17220	119	18704	111	21282	134
12194	131	13788	134	16717	122	17221	119	18710	122	21284	134
12195	131	13790	134	16718	122	17458	93	18716	122	21306	139
12196	131	13998	135	16719	122	17459	93	18765	132	21316	135
12197	131	13999	135	16723	111	17460	93	18803	122	21341	33
12198	131	14001	135	16728	93	17461	93	18805	122	21342	33
12199	131	14009	135	16729	93	17462	93	18808	123	21344	88
12200	131	14010	135	16731	122	17483	93	18811	122	21357	111
12201	130	14012	135	16732	122	17484	93	18850	123	21372	93
12202	130	14020	135	16747	122	17485	93	18874	122	21554	40
12203	130	14021	135	16751	123	17486	93	18882	132	21649	111
12204	130	14023	135	16765	132	17487	93	18912	109	21681	111
12205	130	14042	135	16783	122	17498	93	18943	93	21851	122
12206	130	14043	135	16827	88	17499	93	18946	122	21881	114
12207	130	14045	135	16829	88	17500	93	18965	122	21882	114
12208	130	14053	135	16830	88	17501	93	18970	122	21950	101
12209	130	14054	135	16831	88	17502	93	18975	111	21951	101
12210	130	14056	135	16833	88	17504	93	19277	93	21952	101
12211	68	14097	135	16841	123	17505	93	19297	132	22391	88
12212	68	14098	135	16919	93	17506	93	19321	132	22400	109
12213	68	14100	135	16930	114	17507	93	19721	122	22886	111

22888	111	24428	111	<b>24825</b>	113	<b>26307</b>	117	27473	109	<b>28974</b>	116
23006	122	24429	111	<b>24826</b>	113	26309	117	27500	109	30091	123
24164	111	24430	111	<b>24827</b>	113	26310	117	<b>27595</b>	136	30123	123
24165	111	24432	111	24828	113	<b>26315</b>	117	27597	136	30126	123
24167	111	24433	111	24829	113	26316	117	27734	110	30127	123
24168	111	24434	111	<b>24832</b>	113	26318	117	28097	109	30341	123
24353	111	24435	111	<b>24833</b>	113	26319	117	28104	110	30342	123
24354	111	24436	111	24834	113	26381	93	<b>28145</b>	116	30361	111
24355	111	24437	111	24835	113	26395	136	28161	110	30428	94
24356	111	24438	111	<b>24837</b>	113	<b>26461</b>	136	28224	110	30430	94
24357	111	24439	111	<b>24838</b>	113	26668	88	28232	122	30443	94
24358	111	24441	111	24839	113	26682	137	28254	111	30444	94
24359	111	24442	111	<b>24840</b>	113	<b>26683</b>	137	28346	109	30463	94
24360	111	24443	111	<b>25078</b>	97	26684	137	28347	109	30500	109
24379	111	24444	111	<b>25079</b>	97	<b>26685</b>	137	28349	109	30505	109
24380	111	24445	111	<b>25080</b>	97	<b>26687</b>	137	<b>28799</b>	114	30506	109
24381	111	24446	111	<b>25081</b>	97	26688	137	<b>28802</b>	124	30507	109
24382	111	24447	111	<b>25082</b>	97	<b>26689</b>	137	<b>28832</b>	31	30510	109
24383	111	24448	111	<b>25083</b>	97	<b>26690</b>	137	<b>28833</b>	31	30512	109
24384	111	24459	111	<b>25084</b>	97	<b>26694</b>	137	<b>28834</b>	31	30513	109
24385	111	24460	111	<b>25085</b>	97	<b>26695</b>	137	<b>28835</b>	31	30522	109
24386	111	24461	111	<b>25086</b>	97	26696	137	<b>28836</b>	31	30523	109
24391	111	24462	111	<b>25087</b>	97	<b>26697</b>	137	<b>28837</b>	31	<b>30537</b>	53
24392	111	24463	111	<b>25088</b>	97	<b>26699</b>	137	<b>28838</b>	31	<b>30538</b>	53
24393	111	24464	111	<b>25089</b>	97	<b>26700</b>	137	<b>28839</b>	31	<b>30539</b>	53
24394	111	24465	111	<b>25090</b>	97	<b>26701</b>	137	28840	31	<b>30540</b>	53
24395	111	24466	111	<b>25091</b>	97	<b>26702</b>	137	<b>28841</b>	31	<b>30541</b>	53
24396	111	24531	93	<b>25093</b>	97	<b>26726</b>	137	28842	31	30542	53
24398	111	24603	33	25289	111	<b>26727</b>	137	28843	31	<b>30543</b>	53
24399	111	<b>24686</b>	93	25636	122	<b>26728</b>	137	<b>28848</b>	100	30544	53
24400	111	<b>24791</b>	113	<b>25913</b>	40	<b>26729</b>	137	<b>28849</b>	100	<b>30607</b>	47
24401	111	<b>24802</b>	113	26100	111	<b>26731</b>	137	<b>28850</b>	100	<b>30608</b>	47
24402	111	<b>24803</b>	113	<b>26222</b>	68	26732	137	<b>28854</b>	49	<b>30609</b>	47
24403	111	<b>24804</b>	113	26232	109	<b>26733</b>	137	<b>28855</b>	49	<b>30610</b>	47
24404	111	<b>24805</b>	113	26269	117	<b>26734</b>	137	<b>28857</b>	49	<b>30611</b>	47
24406	111	<b>24806</b>	113	26270	117	<b>26825</b>	88	28858	49	<b>30612</b>	47
24407	111	<b>24807</b>	113	26272	117	<b>26870</b>	136	28863	49	<b>30613</b>	47
24408	111	<b>24808</b>	113	26273	117	26874	114	<b>28864</b>	49	<b>30614</b>	47
24409	111	<b>24809</b>	113	26279	117	<b>26877</b>	48	28866	49	31198	114
24410	111	<b>24810</b>	113	26280	117	<b>26881</b>	48	28867	49	31201	114
24411	111	<b>24811</b>	113	26281	117	<b>26883</b>	48	28872	49	31257	114
24412	111	<b>24812</b>	113	26282	117	27107	109	28873	49	31349	93
24413	111	<b>24813</b>	113	26283	117	27135	136	<b>28953</b>	116	31369	114
24417	111	<b>24814</b>	113	26289	117	27136	136	<b>28954</b>	116	31474	114
24418	111	<b>24816</b>	113	26290	117	27137	136	<b>28955</b>	116	31479	114
24419	111	<b>24817</b>	113	<b>26291</b>	117	27138	136	<b>28956</b>	116	32003	109
24420	111	24818	113	<b>26292</b>	117	27139	136	<b>28967</b>	116	32009	109
24421	111	24819	113	<b>26294</b>	117	27142	136	<b>28968</b>	116	32018	88
24422	111	<b>24821</b>	113	<b>26296</b>	117	27147	29	<b>28969</b>	116	32033	87
24423	111	<b>24822</b>	113	<b>26304</b>	117	<b>27147B</b>	28	<b>28970</b>	116	<b>32035</b>	87
24425	111	<b>24823</b>	113	<b>26305</b>	117	27445	109	<b>28971</b>	116	<b>32039</b>	88
24427	111	<b>24824</b>	113	<b>26306</b>	117	27457	33	<b>28973</b>	116	<b>32041</b>	88

32042	88	<b>35806</b>	75	<b>37867</b>	102	<b>38859</b>	38	<b>39206</b>	118	40310	86
32043	88	<b>35888</b>	100	<b>37868</b>	102	<b>38860</b>	38	<b>39207</b>	31, 51, 118, 135	40311	86
<b>32044</b>	88	35922	134	<b>37869</b>	102	<b>38861</b>	38	<b>39208</b>	31, 51, 118, 135	40312	86
<b>32045</b>	88	<b>36665</b>	87	<b>37895</b>	102	<b>38862</b>	38	<b>39209</b>	31, 51, 118, 135	<b>40313</b>	86
<b>32047</b>	88	36666	87	<b>37896</b>	102	38894	33	39266	103	<b>40314</b>	86
<b>32048</b>	88	36667	87	<b>37897</b>	102	<b>39117</b>	119	39267	103	<b>40315</b>	86
<b>32049</b>	88	<b>36668</b>	87	<b>37898</b>	102	39121	89	39268	103	<b>40316</b>	86
<b>32050</b>	88	36669	87	<b>37899</b>	102	<b>39161</b>	119	39269	103	<b>40317</b>	86
<b>32062</b>	109	36670	87	<b>37905</b>	102	<b>39162</b>	119	39270	103	40318	86
<b>32063</b>	109	<b>36671</b>	87	<b>37906</b>	102	<b>39163</b>	119	39271	102	<b>40319</b>	86
32086	122	36672	87	<b>37907</b>	102	<b>39164</b>	119	<b>39272</b>	102	<b>40320</b>	86
<b>32120</b>	22	36673	87	<b>37908</b>	102	<b>39165</b>	119	<b>39273</b>	102	<b>40321</b>	86
<b>32120B</b>	22	36674	87	<b>37909</b>	102	<b>39166</b>	119	<b>39274</b>	102	40322	86
<b>32352</b>	33	36675	87	37938	111	<b>39167</b>	119	39275	102	40323	86
32361	33	36676	87	38037	89	<b>39168</b>	119	<b>39427</b>	136	40325	86
<b>33358</b>	114	<b>36677</b>	87	<b>38178</b>	46	<b>39169</b>	119	39815	100	40326	86
33791	33	<b>36678</b>	87	38179	46	<b>39170</b>	119	<b>39820</b>	100	40327	86
33983	89	<b>36679</b>	87	38181	46	<b>39171</b>	119	39911	39	40328	86
34014	93	<b>36680</b>	87	38182	46	<b>39172</b>	119	39931	39	<b>40329</b>	86
<b>34324</b>	100	<b>36681</b>	87	38213	39	<b>39173</b>	119	<b>39981</b>	96	<b>40330</b>	86
<b>34325</b>	100	<b>36682</b>	87	38214	39	39174	119	<b>40038</b>	136	<b>40331</b>	86
<b>34359</b>	75	<b>36683</b>	87	<b>38308</b>	23, 91	39175	119	<b>40039</b>	136	<b>40332</b>	86
<b>34360</b>	75	<b>36684</b>	87	38436	111	<b>39176</b>	119	<b>40040</b>	136	<b>40333</b>	86
<b>34361</b>	74	<b>36685</b>	87	38437	111	<b>39177</b>	119	<b>40066</b>	96	<b>40334</b>	86
<b>34362</b>	74	<b>36686</b>	87	38438	111	<b>39178</b>	119	40068	96	<b>40335</b>	86
<b>34363</b>	74	<b>36687</b>	87	<b>38446</b>	75	39179	119	<b>40170</b>	39	<b>40336</b>	86
<b>34364</b>	77	<b>36688</b>	87	<b>38447</b>	75	39180	119	<b>40208</b>	139	<b>40337</b>	86
<b>34365</b>	77	<b>36689</b>	87	38456	22	<b>39181</b>	119	<b>40270</b>	89	<b>40338</b>	86
<b>34366</b>	76	36690	87	38456B	22	39182	119	<b>40271</b>	89	<b>40339</b>	86
<b>34463</b>	89	<b>36691</b>	87	38457	22	39183	119	40272	89	<b>40340</b>	86
<b>34470</b>	40	<b>36692</b>	87	38457B	22	39184	119	40273	89	<b>40402</b>	25
<b>34569</b>	52	<b>36693</b>	87	38458	22	<b>39185</b>	119	40274	89	<b>40403</b>	25
34898	110	<b>36694</b>	87	38458B	22	39186	119	40277	89	<b>40404</b>	25
<b>34961</b>	52	<b>36695</b>	87	38459	22	39187	119	<b>40278</b>	89	<b>40405</b>	25
<b>34982</b>	100	36696	87	38459B	22	39188	119	40279	89	<b>40406</b>	25
<b>34992</b>	23, 77, 91	<b>36697</b>	87	<b>38460</b>	22	<b>39189</b>	119	40280	89	<b>40407</b>	25
34998	89	<b>36698</b>	87	<b>38460B</b>	22	<b>39190</b>	119	40281	89	<b>40408</b>	25
<b>35126</b>	48	<b>36699</b>	87	<b>38461</b>	22	39191	119	<b>40291</b>	89	<b>40409</b>	25
35157	136	<b>36700</b>	87	<b>38461B</b>	22	<b>39192</b>	119	<b>40292</b>	89	40412	21
35158	136	36794	109	38597	123	<b>39193</b>	119	40293	89	40413	21
35159	136	36795	109	<b>38699</b>	74	<b>39194</b>	119	40294	89	<b>40414</b>	21
<b>35361</b>	89	36796	109	38799	26	<b>39195</b>	119	40295	89	<b>40415</b>	21
<b>35564</b>	48	37348	49	38799B	26	39196	119	<b>40298</b>	89	40416	21
<b>35565</b>	48	37515	122	38800	26	<b>39197</b>	119	40299	89	<b>40417</b>	21
35599	29	<b>37519</b>	69	38800B	26	39198	119	<b>40300</b>	89	40418	21
35599B	28	37860	103	38801	26	39199	119	40301	89	40419	21
<b>35644</b>	44	<b>37861</b>	103	38801B	26	39200	119	40302	89	<b>40420</b>	21
<b>35733</b>	68	37862	103	38802	26	<b>39201</b>	119	40305	86	<b>40421</b>	21
35734	68	<b>37863</b>	103	38802B	26	39202	119	40306	86	<b>40422</b>	21
<b>35795</b>	44	37864	103	<b>38835</b>	96	39203	119	40307	86	<b>40423</b>	21
<b>35804</b>	44	<b>37865</b>	102	<b>38857</b>	38	<b>39204</b>	118	<b>40308</b>	86	40425	96
<b>35805</b>	75	<b>37866</b>	102	<b>38858</b>	38	<b>39205</b>	118	40309	86	<b>40433</b>	46

<b>40434</b> . . . . .	46	<b>42815</b> . . . . .	31, 51, 135	<b>44958</b> . . . . .	137	46224 . . . . .	122	46878 . . . . .	90	<b>49101</b> . . . . .	121
<b>40435</b> . . . . .	46	42845 . . . . .	123	<b>44959</b> . . . . .	137	46239 . . . . .	119	<b>46879</b> . . . . .	90	<b>49102</b> . . . . .	121
<b>40436</b> . . . . .	46	42965 . . . . .	105	<b>44960</b> . . . . .	137	46310 . . . . .	23, 91	46880 . . . . .	90	<b>49103</b> . . . . .	121
<b>40437</b> . . . . .	46	<b>42966</b> . . . . .	105	44961 . . . . .	137	<b>46582</b> . . . . .	30	46881 . . . . .	90	<b>49104</b> . . . . .	121
<b>40438</b> . . . . .	46	<b>42967</b> . . . . .	105	<b>44962</b> . . . . .	137	<b>46583</b> . . . . .	30	46882 . . . . .	90	<b>49105</b> . . . . .	121
<b>40439</b> . . . . .	46	<b>42969</b> . . . . .	105	<b>44963</b> . . . . .	137	<b>46584</b> . . . . .	30	46933 . . . . .	125	<b>49106</b> . . . . .	121
<b>40440</b> . . . . .	46	43491 . . . . .	89	<b>44964</b> . . . . .	137	46585 . . . . .	39	<b>46934</b> . . . . .	125	<b>49107</b> . . . . .	121
40497 . . . . .	93	<b>43553</b> . . . . .	105	<b>44966</b> . . . . .	137	46586 . . . . .	40	<b>47144</b> . . . . .	121	49284 . . . . .	122
40508 . . . . .	39	43582 . . . . .	105	<b>44967</b> . . . . .	137	46587 . . . . .	40	47486 . . . . .	123	<b>49366</b> . . . . .	52
<b>40564</b> . . . . .	23, 91	<b>43583</b> . . . . .	105	<b>44968</b> . . . . .	137	<b>46588</b> . . . . .	38	47589 . . . . .	114	49377 . . . . .	86
40572 . . . . .	100	43830 . . . . .	105	44969 . . . . .	137	<b>46589</b> . . . . .	38	47801 . . . . .	90	49393 . . . . .	87
<b>40610</b> . . . . .	40	<b>43831</b> . . . . .	105	<b>44970</b> . . . . .	137	46590 . . . . .	38	<b>47802</b> . . . . .	90	49395 . . . . .	87
<b>40611</b> . . . . .	40	43834 . . . . .	110	<b>44971</b> . . . . .	137	46591 . . . . .	38	<b>47803</b> . . . . .	90	<b>49490</b> . . . . .	121
<b>40612</b> . . . . .	40	<b>43835</b> . . . . .	110	<b>44972</b> . . . . .	137	46592 . . . . .	38	47804 . . . . .	90	<b>49491</b> . . . . .	121
<b>40613</b> . . . . .	40	<b>43836</b> . . . . .	110	<b>44974</b> . . . . .	137	46593 . . . . .	38	47805 . . . . .	90	49492 . . . . .	121
40627 . . . . .	33	43837 . . . . .	110	45065 . . . . .	49	46614 . . . . .	49	47806 . . . . .	90	<b>49493</b> . . . . .	121
40628 . . . . .	33	43838 . . . . .	110	45066 . . . . .	49	46615 . . . . .	49	47807 . . . . .	90	49494 . . . . .	121
40703 . . . . .	105	43839 . . . . .	110	<b>45102</b> . . . . .	66	46618 . . . . .	49	47808 . . . . .	90	49876 . . . . .	122
<b>40704</b> . . . . .	105	43840 . . . . .	110	45103 . . . . .	66	46619 . . . . .	49	47809 . . . . .	90	49881 . . . . .	114
<b>40705</b> . . . . .	105	<b>43841</b> . . . . .	110	45104 . . . . .	66	<b>46630</b> . . . . .	46	47810 . . . . .	90	49950 . . . . .	132
<b>40754</b> . . . . .	52	43842 . . . . .	110	<b>45105</b> . . . . .	66	<b>46631</b> . . . . .	46	47811 . . . . .	90	50085 . . . . .	114
<b>40821</b> . . . . .	23, 91	<b>43843</b> . . . . .	110	45106 . . . . .	66	46632 . . . . .	46	47812 . . . . .	90	<b>50254</b> . . . . .	23, 91
40828 . . . . .	122	<b>43844</b> . . . . .	110	<b>45107</b> . . . . .	67	<b>46633</b> . . . . .	46	<b>47813</b> . . . . .	90	50257 . . . . .	23, 91
<b>40882</b> . . . . .	96	43845 . . . . .	110	<b>45108</b> . . . . .	59	46640 . . . . .	30	<b>47814</b> . . . . .	90	50258 . . . . .	23, 91
40887 . . . . .	96	<b>43846</b> . . . . .	110	<b>45109</b> . . . . .	59	46641 . . . . .	30	<b>47815</b> . . . . .	90	50346 . . . . .	136
40889 . . . . .	96	<b>43847</b> . . . . .	51	<b>45618</b> . . . . .	66	46642 . . . . .	30	47816 . . . . .	90	<b>50420</b> . . . . .	23, 91
40910 . . . . .	97	<b>43848</b> . . . . .	51	<b>45620</b> . . . . .	66	46648 . . . . .	93	47817 . . . . .	90	50480 . . . . .	134
40911 . . . . .	97	43849 . . . . .	51	45889 . . . . .	122	46649 . . . . .	39	47818 . . . . .	90	50664 . . . . .	114
<b>41323</b> . . . . .	29	<b>43850</b> . . . . .	48	<b>46050</b> . . . . .	44	<b>46654</b> . . . . .	96	<b>47819</b> . . . . .	90	<b>50758</b> . . . . .	21
<b>41323B</b> . . . . .	28	<b>43851</b> . . . . .	48	46169 . . . . .	119	46655 . . . . .	96	47820 . . . . .	90	50760 . . . . .	21
41334 . . . . .	77	<b>43852</b> . . . . .	48	46170 . . . . .	119	46853 . . . . .	90	<b>47821</b> . . . . .	90	50761 . . . . .	21
<b>41347</b> . . . . .	139	43883 . . . . .	33	46171 . . . . .	119	46854 . . . . .	90	<b>47822</b> . . . . .	90	50762 . . . . .	21
41382 . . . . .	22	<b>43934</b> . . . . .	52	46172 . . . . .	119	46855 . . . . .	90	47823 . . . . .	90	50763 . . . . .	21
41382B . . . . .	22	44028 . . . . .	100	46173 . . . . .	119	46856 . . . . .	90	47824 . . . . .	90	<b>50764</b> . . . . .	21
41383 . . . . .	21	<b>44029</b> . . . . .	100	46174 . . . . .	119	<b>46857</b> . . . . .	90	<b>48035</b> . . . . .	121	<b>50765</b> . . . . .	21
41384 . . . . .	21	44030 . . . . .	100	46175 . . . . .	119	46858 . . . . .	90	<b>48300</b> . . . . .	99	<b>50766</b> . . . . .	21
<b>41861</b> . . . . .	44	44125 . . . . .	33	46176 . . . . .	119	46859 . . . . .	90	<b>48301</b> . . . . .	99	<b>50843</b> . . . . .	25
<b>41929</b> . . . . .	105	44383 . . . . .	33	<b>46177</b> . . . . .	119	46860 . . . . .	90	<b>48302</b> . . . . .	99	<b>50844</b> . . . . .	25
42390 . . . . .	105	44406 . . . . .	114	46178 . . . . .	119	46861 . . . . .	90	<b>48304</b> . . . . .	99	50911 . . . . .	89
<b>42655</b> . . . . .	105	<b>44615</b> . . . . .	44	46179 . . . . .	119	46862 . . . . .	90	<b>48305</b> . . . . .	99	51082 . . . . .	23, 91
42716 . . . . .	89	<b>44711</b> . . . . .	96	46180 . . . . .	119	46863 . . . . .	90	<b>48306</b> . . . . .	99	<b>51408</b> . . . . .	25
42774 . . . . .	29	<b>44838</b> . . . . .	96	46181 . . . . .	119	46864 . . . . .	90	48316 . . . . .	99	<b>51543</b> . . . . .	25
42774B . . . . .	28	44891 . . . . .	123	46182 . . . . .	119	<b>46871</b> . . . . .	90	48317 . . . . .	99	<b>51544</b> . . . . .	25
<b>42806</b> . . . . .	51	44951 . . . . .	137	46183 . . . . .	119	46872 . . . . .	90	48318 . . . . .	99	51811 . . . . .	21
<b>42807</b> . . . . .	51	<b>44952</b> . . . . .	137	46184 . . . . .	119	46873 . . . . .	90	48320 . . . . .	99	52193 . . . . .	122
<b>42808</b> . . . . .	51	<b>44953</b> . . . . .	137	46195 . . . . .	119	46874 . . . . .	90	48321 . . . . .	99	52227 . . . . .	136
42809 . . . . .	51	<b>44954</b> . . . . .	137	46196 . . . . .	119	46875 . . . . .	90	48322 . . . . .	99	52290 . . . . .	21
<b>42810</b> . . . . .	51	44955 . . . . .	137	46197 . . . . .	119	<b>46876</b> . . . . .	90	48897 . . . . .	136	52306 . . . . .	132
42811 . . . . .	51	<b>44956</b> . . . . .	137	46204 . . . . .	49	46877 . . . . .	90	<b>49100</b> . . . . .	121	52332 . . . . .	21

52338	21	<b>53372</b>	128	53496	136	<b>54566</b>	85	<b>54702</b>	64	<b>54835</b>	64
52339	21	<b>53373</b>	128	53501	122	<b>54567</b>	85	<b>54703</b>	64	<b>54836</b>	64
52340	21	<b>53374</b>	127	53699	134	54602	114	<b>54704</b>	64	<b>54872</b>	65
<b>52375</b>	25	<b>53375</b>	127	<b>53726</b>	85	<b>54652</b>	64	<b>54705</b>	64	<b>54873</b>	65
<b>52376</b>	25	<b>53376</b>	129	<b>53758</b>	85	<b>54653</b>	64	<b>54709</b>	65	54881	134
<b>52378</b>	25	<b>53377</b>	128	<b>53814</b>	85	<b>54654</b>	64	<b>54710</b>	64	<b>54896</b>	76
52400	44	<b>53378</b>	128	<b>53824</b>	85	<b>54655</b>	64	<b>54713</b>	65	<b>54897</b>	74
52401	44	<b>53379</b>	128	<b>53834</b>	85	<b>54656</b>	64	<b>54714</b>	64	<b>54898</b>	74
52421	109	<b>53380</b>	127	<b>53876</b>	85	<b>54657</b>	64	<b>54715</b>	65	<b>54899</b>	77
52422	109	<b>53381</b>	127	<b>53899</b>	85	<b>54658</b>	64	<b>54716</b>	64	<b>54900</b>	77
52423	109	<b>53382</b>	129	<b>53900</b>	85	<b>54659</b>	64	<b>54717</b>	65	54935	134
52424	109	<b>53383</b>	128	<b>53902</b>	85	<b>54660</b>	64	<b>54718</b>	64	<b>55061</b>	76
52425	109	<b>53384</b>	128	<b>53904</b>	85	<b>54661</b>	64	<b>54723</b>	65	55282	123
52465	122	<b>53385</b>	128	<b>53905</b>	85	<b>54662</b>	64	<b>54725</b>	64	55291	122
<b>52466</b>	44	<b>53386</b>	127	<b>53906</b>	85	<b>54663</b>	64	<b>54726</b>	65	55293	114
52745	114	<b>53387</b>	127	<b>53907</b>	85	<b>54664</b>	64	<b>54727</b>	64	<b>55343</b>	58
52787	117	<b>53388</b>	129	<b>53908</b>	85	<b>54665</b>	64	<b>54784</b>	64	<b>55346</b>	58
52928	94	<b>53389</b>	128	<b>53910</b>	85	<b>54666</b>	64	<b>54785</b>	64	<b>55347</b>	58
53220	117	<b>53390</b>	128	<b>53911</b>	85	<b>54667</b>	64	<b>54801</b>	113	<b>55348</b>	58
53249	94	<b>53391</b>	128	<b>53912</b>	85	<b>54668</b>	64	<b>54802</b>	113	<b>55349</b>	58
53250	94	<b>53392</b>	127	<b>53913</b>	85	<b>54669</b>	64	<b>54803</b>	113	<b>55350</b>	58
53333	114	<b>53393</b>	127	<b>53914</b>	85	<b>54670</b>	64	<b>54804</b>	113	<b>55351</b>	58
<b>53346</b>	129	<b>53394</b>	129	<b>53915</b>	85	<b>54671</b>	64	<b>54805</b>	43	<b>55352</b>	58
<b>53347</b>	128	<b>53395</b>	128	<b>53916</b>	85	<b>54672</b>	64	<b>54806</b>	43	<b>55356</b>	58
<b>53348</b>	128	<b>53396</b>	128	<b>53917</b>	85	<b>54673</b>	64	<b>54807</b>	43	<b>55357</b>	58
<b>53349</b>	128	<b>53397</b>	128	<b>53918</b>	85	<b>54674</b>	64	<b>54808</b>	43	<b>55360</b>	58
<b>53350</b>	127	<b>53398</b>	127	<b>53919</b>	85	<b>54675</b>	64	<b>54809</b>	43	<b>55361</b>	58
<b>53351</b>	127	<b>53399</b>	127	53987	122	<b>54676</b>	64	<b>54810</b>	43	<b>55362</b>	58
<b>53352</b>	129	<b>53400</b>	129	54042	122	<b>54680</b>	58	<b>54811</b>	43	<b>55363</b>	58
<b>53353</b>	128	<b>53401</b>	128	54053	122	<b>54681</b>	58	<b>54812</b>	43	<b>55364</b>	58
<b>53354</b>	128	<b>53402</b>	128	<b>54124</b>	85	<b>54683</b>	58	<b>54813</b>	43	<b>55380</b>	58
<b>53355</b>	128	<b>53403</b>	128	<b>54125</b>	85	<b>54684</b>	58	<b>54814</b>	43	<b>55381</b>	58
<b>53356</b>	127	<b>53404</b>	129	54244	122	<b>54685</b>	58	<b>54815</b>	43	55416	134
<b>53357</b>	127	<b>53405</b>	128	54301	134	<b>54686</b>	58	<b>54816</b>	43	55521	134
<b>53358</b>	129	<b>53406</b>	128	54308	89	<b>54687</b>	58	<b>54817</b>	41	55729	134
<b>53359</b>	128	<b>53407</b>	128	54408	122	<b>54689</b>	58	<b>54818</b>	41	55730	134
<b>53360</b>	128	<b>53408</b>	129	<b>54503</b>	85	<b>54690</b>	58	<b>54819</b>	42	55731	134
<b>53361</b>	128	<b>53409</b>	128	<b>54504</b>	85	<b>54691</b>	58	<b>54820</b>	42	55732	134
<b>53362</b>	127	<b>53410</b>	128	<b>54505</b>	85	<b>54692</b>	58	<b>54821</b>	42	55733	134
<b>53363</b>	127	<b>53411</b>	128	<b>54506</b>	85	<b>54693</b>	58	<b>54822</b>	42	<b>55888</b>	99
<b>53364</b>	129	<b>53412</b>	129	<b>54509</b>	85	<b>54694</b>	58	<b>54823</b>	42	<b>58848</b>	99
<b>53365</b>	128	<b>53413</b>	128	<b>54510</b>	85	<b>54695</b>	58	<b>54824</b>	42	<b>58849</b>	99
<b>53366</b>	128	<b>53414</b>	128	<b>54559</b>	85	<b>54696</b>	58	<b>54825</b>	64	<b>58850</b>	99
<b>53367</b>	128	<b>53415</b>	128	<b>54561</b>	85	<b>54697</b>	64	<b>54826</b>	64	<b>59815</b>	99
<b>53368</b>	127	<b>53416</b>	129	<b>54562</b>	85	<b>54698</b>	64	<b>54829</b>	64	<b>59820</b>	99
<b>53369</b>	127	<b>53417</b>	128	<b>54563</b>	85	<b>54699</b>	64	<b>54830</b>	64		
<b>53370</b>	129	<b>53418</b>	128	<b>54564</b>	85	<b>54700</b>	64	<b>54831</b>	64		
<b>53371</b>	128	<b>53419</b>	128	<b>54565</b>	85	<b>54701</b>	64	<b>54832</b>	64		

# Conditions of Sales

## 1. NEW ACCOUNT REQUIREMENTS

When applying for the right to sell our product and to become an approved distributor, a minimum stocking order of \$1000.00 may be required as part of our partnering commitment

## 2. ORDERING

All items should be ordered by part number and placed through your local Superior distributor, they stock many of our products for your convenience. Call us for the one nearest you.

An order shall be deemed to have been accepted when it has been confirmed by us in writing or when it is supplied. The times of delivery indicated in our order confirmation shall be deemed to have been agreed upon as approximate delivery times. They shall be deemed to have been complied with, if the goods were dispatched within the period agreed upon or if – within said period – the buyer was advised that the goods are ready for shipment. The time of delivery shall be reasonably extended – also when a delay in delivery has occurred – in case of unforeseen and inevitable events that we were unable to avert in spite of exercising reasonable care, such as a shortage of raw materials, an interruption of operations, the effects of labor disputes or the like. If, through any of the aforementioned circumstances, delivery or performance becomes impossible, we shall thus be exempt from our obligation to deliver.

In any case where products of a special manufacture are ordered, it is the responsibility of the buyer to ensure that any drawings or samples do not infringe the legal patents or protection rights of a third party. We are not obliged to check for such legal rights. Where there is a liability of the supplier, it is the responsibility of the buyer to indemnify himself against any such liability. If specialty manufactures are supplied, we reserve production-related and, if catalogue articles are supplied, we reserve packing-related reasonable deviations from the quantities ordered. Partial deliveries shall be permissible.

## 3. MINIMUM ORDER

Each order must be \$50.00 Net Per Invoice to a single destination. Each item must be ordered in a full "Standard Package."

## 4. PRICING

Prices listed in this catalog are suggested list prices and subject to change without notice, although every effort will be made to announce any changes 30 days in advance. Stenographic, clerical and other errors, should they occur, on special quotes or in this catalog are subject to correction. All agreements, which include sales, are contingent upon strikes, fires, accidents, delays of nature or other causes unavoidable beyond our control.

## 5. TERMS OF PAYMENT

Standard net terms are 30 days. All invoices over 30 days will be considered delinquent, and all in-house orders will be placed on hold until balance of the account is brought below 31 days. Any account placed for collection will receive a finance charge of 1-1/2% per month (18% per year) to balances over 30 days, plus attorney fees and costs. To establish an open account, your firm must supply three industrial and one bank reference.

## 6. FREIGHT

Superior Abrasives, LLC will prepay freight charges for one delivery to the customer on order values of \$500.00 or more. All orders with a value less than \$500.00, the cost of freight will be added to the distributor's invoice. Each release from a blanket order must total \$500 net or more to receive prepaid freight. Export shipments will be shipped freight collect. A separate charge may be made for customer's special routing instructions. All orders are sold in Ohio and title passes to the buyer when your order leaves Superior's factory. The buyer is solely responsible for their shipment. By placing an order, you authorize us to act on your behalf to engage a common carrier to deliver your order to you.

## 7. ADD-ON POLICY

Due to the speed of our order entry, manufacturing process and rapid shipment of goods, we find it detrimental to our service to accept additions to existing orders.

## 8. QUANTITY VARIANCE

Due to the nature of manufacturing, Superior reserves the right to over-ship or under-ship the quantity ordered by 10%.

## 9. RETURNED GOODS POLICY

We will not accept the return of merchandise without our "RETURN AUTHORIZATION NUMBER" clearly marked on all boxes. When a R/A number is issued by our Customer Service Department, they will send all information to you. The merchandise must be returned to Superior within 30 days from the date the R/A number was issued. After 30 days, R/A numbers are automatically canceled in house and the request will become null and void. All credits must be taken within six months or they will be disallowed. Superior reserves the right to accept returns in quantities relative to our established stocking levels. Freight is to be prepaid and a \$15.00 or 15% (whichever is greater) restocking and handling charge will apply unless "Superior" is at fault. Many of our items fall into a "non-stock" or "special order" category; items in this group are not returnable. In any case no merchandise may be returned after six months from date of shipment from our factory. All claims of shortages must be made within 10 days after receipt of goods.

All goods supplied shall remain our property until all our claims, in particular any remaining claims against the buyer, are met (paid) in full. This shall apply even if payment of specially designated claims is made. The orderer shall be entitled to resell the goods supplied by us within the normal course of business; but shall assign to us all claims up to the amount of the final invoice amount (including value-added tax) that will accrue to him from the resale to his buyers or third parties. We agree to release upon the buyer's request the securities due to us to such an extent that the value of our securities exceeds the claims to be secured by more than twenty (20) percent; we shall be entitled to select the securities to be released. If the orderer suspends his payments, we shall be entitled to take back the goods against issuing a credit note. The buyer shall be obliged to surrender the goods. If we exercise our reservations of ownership, this shall not mean that we withdraw from the contract. Moreover, we shall be entitled to withdraw from the fulfillment of further existing delivery obligations.

#### **10. LIMITED WARRANTY**

Superior Abrasives, LLC. warrants that its products shall be free from defects in material and workmanship under normal and ordinary usage when owned by the original purchaser for a period of six months from the date such products are shipped from Superior's factory. Any claim for breach of Warranty must be brought within 30 days after customer's receipt of the product and customer must cease use of the product pending Superior's substantiation of any warranty claim. In the event a product defect shall occur, Superior shall, at its option, repair or replace the defective product(s) or, upon return of such product(s), cancel the transaction and refund to customer any amount previously paid therefor.

**THIS WARRANTY EXPRESSLY IS MADE IN LIEU OF ANY AND ALL OTHER WARRANTIES, EXPRESS OR IMPLIED INCLUDING THE WARRANTIES OF MERCHANTABILITY AND FITNESS FOR A PARTICULAR PURPOSE. SUPERIOR ABRASIVES, LLC.'S EXCLUSIVE DUTIES TO PURCHASERS OF ITS PRODUCTS WILL BE AS HEREINABOVE PROVIDED. CUSTOMERS SHALL HAVE NO CLAIM AGAINST SUPERIOR FOR INCIDENTAL OR CONSEQUENTIAL DAMAGES.**

#### **11. SAFETY WARNING**

Coated, bonded and non-woven abrasives are dangerous if used improperly. Please comply with all safety regulations set by the AMERICAN NATIONAL STANDARDS INSTITUTE (ANSI) Z87.1, also by OCCUPATIONAL SAFETY AND HEALTH ACT (OSHA); covering eye face and body protection, wheel and discs speeds safety guards, flanges, mounting and operating procedures.

# **SUPERIOR**

## **ABRASIVES**

PRODUCT GUIDE & REFERENCE MANUAL 26  
Supersedes all previous literature  
Reorder Number 70600

**SUPERIOR ABRASIVES, LLC**

1620 Fieldstone Way  
Vandalia, OH 45377

Call: (800) 235-9123  
Fax: (800) 841-3441

[sales@superiorabrasives.com](mailto:sales@superiorabrasives.com)



# SUPERIOR

ABRASIVES

PRODUCT GUIDE & REFERENCE MANUAL 26

Supersedes all previous literature  
Reorder Number 70600

**SUPERIOR ABRASIVES, LLC**

1620 Fieldstone Way  
Vandalia, OH 45377

Call: (800) 235-9123  
Fax: (800) 841-3441

[sales@superiorabrasives.com](mailto:sales@superiorabrasives.com)

©2019 Superior Abrasives, LLC. All rights reserved.

