

THE ALUMA-HOGS

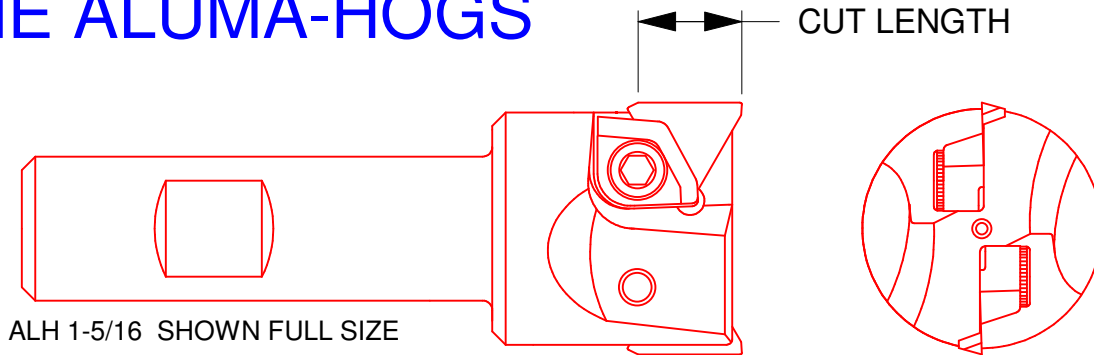

We started making ALUMA-HOGS in 1982. In 1997 we introduced the SHEAR-HOG; see back cover. With its high shear inserts, and no top clamps, the SHEAR-HOG outperforms the ALUMA-HOGS by 50% in Metal Removal rates. We will stock Aluma-Hogs, inserts, and parts as long as needed.

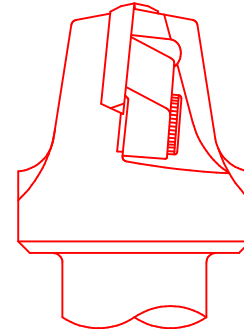

Number	Dia.	Shank Dia.	OAL Lgth.	Cut Lgth.	Insert & Qty.	Clamp Ref.	Shim Ref.	
ALH1A	1.0	3/4	3.75	1/4	TEG2.522 (2)	CL1		
ALH1B	1.0	1.0	3.75	1/4	TEG2.522 (2)	CL1		
ALH1-5/16	1.312	3/4	3.75	1/2	TFG32MF (2)	CL2		
ALH1-7/8A	1.875	3/4	3.87	3/4	TEG42MF (2)	CL3		
ALH1-7/8B	1.875	1.0	4.12	3/4	TEG42MF (2)	CL3		
ALH2	2.0	1.0	4.12	3/4	TEG42MF (2)	CL3		
ALH3S	3.0	1.0	4.12	3/4	TEG42MF (3)	CL3	SM37	
ALH4S	4.0	1.0	4.25	3/4	TEG42MF (4)	CL3	SM37	

Inserts/Hardware	Relief Angle	
TEG2.522 (.031 R.)	20°	
TEG2.52MF (Mill Flat)	20°	
TFG322 (.031 R.)	25°	
TFG32MF (Mill Flat)	25°	
TEG422 (.031 R.)	20°	
TEG42MF (Mill Flat)	20°	
CL1 OR CL2 Clamp		
CL3 Clamp		
SM37 Shim, Modified		

*Suggested Starting Data:
Non-Ferrous ONLY
500/10,000 SFM; .002/.010 IPT*

See back cover and inside front cover for information on the SHEAR-HOG, which will rough mill Aluminum at 6 CIM per HP.

Screws included with any Clamp/Shim orders.

