

Product information

- balancing quality: G2.5 / 25,000 rev./min or U < 1 gmm
- robust, radially operated length setting
- max. deviation f. concentricity 3 µm
- for tool shank tolerance h6
- to DIN 69882-7
- HSK-C to ISO 12164-1/DIN 69893-1

Scope of delivery

- incl. hexagon chuck key, Series no. 4912
- incl. hexagon key inserts for radial length setting

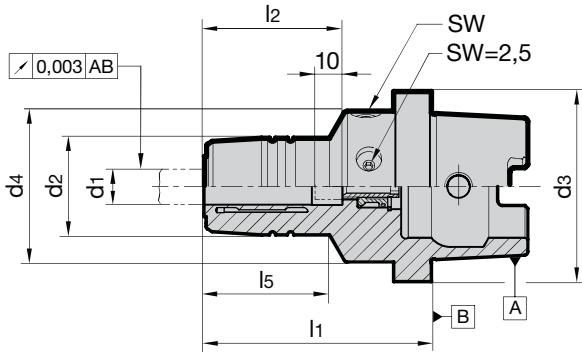

										Series no.	4295
HSK-C d ₃	for shank Ø d ₁ h6 mm	d ₂ mm	d ₄ mm	l ₁ mm	l ₂ mm	l ₅ mm	SW	kg	Code no.	EDP Number	
40	6	26	40	60	37	30	4	0.5	6.040	9042950060400	
40	8	28	40	60	37	30	4	0.5	8.040	9042950080400	
40	10	30	40	65	41	35	4	0.5	10.040	9042950100400	
40	12	32	40	70	46	40	4	0.6	12.040	9042950120400	
50	6	26	50	60	37	30	4	0.6	6.050	9042950060500	
50	8	28	50	60	37	30	5	0.6	8.050	9042950080500	
50	10	30	50	65	41	35.5	5	0.6	10.050	9042950100500	
50	12	32	50	75	46	45	5	0.8	12.050	9042950120500	
50	14	34	50	75	46	45	5	0.9	14.050	9042950140500	
50	16	38	50	80	49	50	5	0.9	16.050	9042950160500	
50	18	40	50	80	49	50	5	1.0	18.050	9042950180500	
50	20	42	50	80	51	50	5	1.0	20.050	9042950200500	
63	6	26	50	60	37	26.0	5	1.0	6.063	9042950060630	
63	8	28	50	60	37	26.0	5	1.1	8.063	9042950080630	
63	10	30	50	65	41	32.0	5	1.1	10.063	9042950100630	
63	12	32	50	75	46	42.5	5	1.1	12.063	9042950120630	
63	14	34	50	75	46	43.0	5	1.1	14.063	9042950140630	
63	16	38	50	80	49	49.0	5	1.2	16.063	9042950160630	
63	18	40	50	80	49	50.0	5	1.2	18.063	9042950180630	
63	20	42	50	80	51	50.5	5	1.2	20.063	9042950200630	
63	25	50	63	95	57	59.5	6	1.8	25.063	9042950250630	
63	32	60	63	100	61	60.0	6	2.3	32.063	9042950320630	

Operating instructions for Hydraulic chucks

TECHNICAL INFORMATION AND ADVANTAGES

Clamping standard tool shanks to DIN 6535 in hydraulic chucks

Direct clamping
of tool preferred
run-out ≤ 0.003 mm

Form HA $\varnothing 6 \dots 20$ mm



Form HA $\varnothing 25 \dots 32$ mm

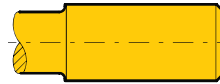

Form HB $\varnothing 6 \dots 20$ mm



Clamping of tool shank
only with reduction bushes
run-out ≤ 0.005 mm

Form HB $\varnothing 25 \dots 32$ mm



Form HE $\varnothing 6 \dots 20$ mm

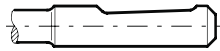

Form HE $\varnothing 25 \dots 32$ mm



General notes:

Our hydraulic chucks must not be operated with motor-driven tools (impulse screwdrivers or similar). The hexagonal key should not exceed the key size over its entire length, this largely prevents excessive torque being transferred. We recommend the hexagon clamping key, Series no. 4912. A tightening moment of 10 Nm must not be exceeded.

Gühring Hydraulic chucks with increased clamping force

Hydraulic chucks are suitable for clamping rotary symmetrical tools or workpieces. Straight shank tools without drive flats may be clamped up to $\varnothing 32$ mm, but also shanks according to DIN 6535 form HA and HB up to $\varnothing 20$ mm without reduction sleeves. The given values in the table below are not to be exceeded. If the inserted length is less than the given minimum insertion depth or other tool shanks than specified above are applied, lower accuracy and breakage may occur!

Above all it is the high revolutions with High-Speed-Cutting operations that puts special demands on the tool holder. The clamping of the tool in a hydraulic chuck is, therefore, especially significant. Gühring has developed a hydraulic chuck that offers reliable and powerful clamping with higher torque figures, guaranteeing excellent tool clamping in the tool holder.

Combined with precise concentricity (max. 3 μm deviation from concentricity), a very fast and simple tool change as well as the vibration cushioning effect of the pressure chamber, the new hydraulic chuck can tackle the most demanding of machining tasks. The result is optimal tool life and excellent surface qualities or dimensional accuracy of the workpiece respectively.

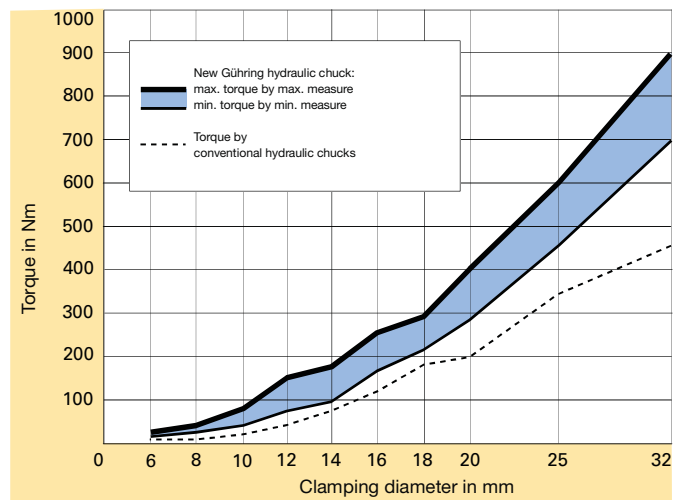

Considerably higher:
The clamping force of Gühring's new HSK-A hydraulic chuck in comparison to conventional chucks.

Hydraulic chucks

TECHNICAL INFORMATION AND ADVANTAGES

Modern machining processes place heavy demands on tool holding. Hydraulic chucks provide excellent clamping characteristics combined with precise concentricity. Furthermore, they enable a simple and fast tool change, with the assistance of a special extraction key. Turning the pressure screw generates sufficient pressure in the pressure chamber resulting in an elastic deformation of the clamping bush, providing powerful tool clamping and precise concentricity. A safe and powerful fit is guaranteed. If reduction sleeves are applied that are able to hold varying tool diameters, the tool application may be extended without problem. If such bushes are not applied, it is essential to observe the minimum clamping length!

A summary of the advantages:

- precise tool clamping with a maximum 3 µm deviation from concentricity
- transmission of high torque through (excellent clamping) optimised bush clamping system
- high speed compatibility (no centrifugal forces from clamping segments)
- precise concentricity, therefore excellent surface qualities and dimensional accuracy of the workpiece
- rapid tool change thanks to simple operation of the clamping screw
- optimal tool life
- hydraulic cushioning has vibration absorbing effect

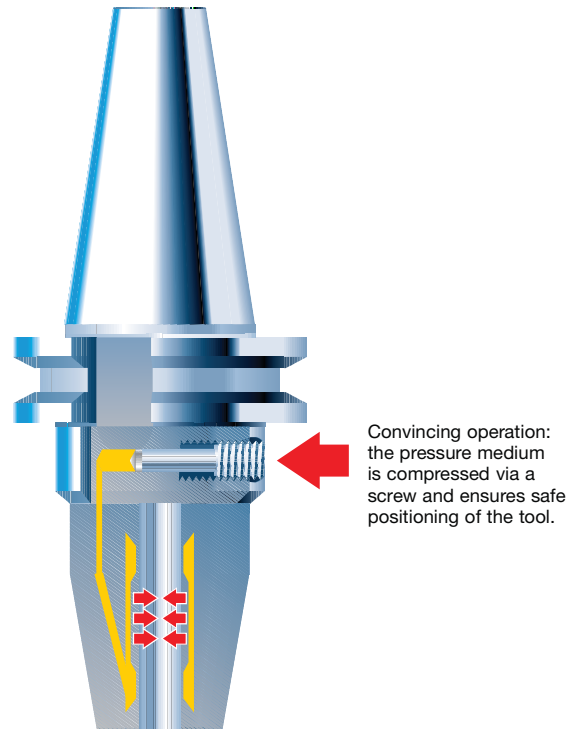
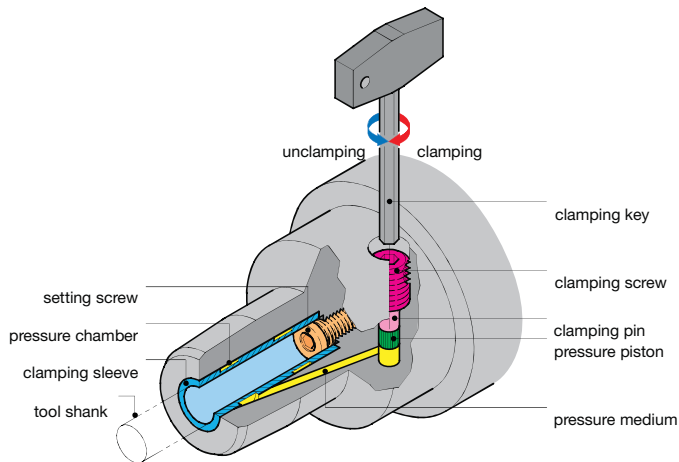

for shank-Ø in mm	max. r.p.m. in 1/min	max. transferable torque in Nm	min. insertion depth in mm	max. adjustment l ₃ mm	max. rad. force F on chuck with 50 mm from the nose in N	operating temperature in °C	max. coolant pressure in bar
3 h6	50 000	2.5	27	7	25	20 - 50	80
4 h6	50 000	6	27	7	40	20 - 50	80
5 h6	50 000	10	27	7	65	20 - 50	80
6 h6	50 000	16	27	10	225	20 - 50	80
8 h6	50 000	26	27	10	370	20 - 50	80
10 h6	50 000	50	31	10	540	20 - 50	80
12 h6	50 000	82	36	10	650	20 - 50	80
14 h6	50 000	125	36	10	900	20 - 50	80
16 h6	50 000	190	39	10	1410	20 - 50	80
18 h6	50 000	275	39	10	1580	20 - 50	80
20 h6	50 000	310	41	10	1860	20 - 50	80
25 h6	25 000	520	47	10	4400	20 - 50	80
32 h6	25 000	770	51	10	6500	20 - 50	80