

DATA  
OUTPUT

ATTENTION: CAN NOT USE CLAMP  
FOR PROTRACTORS (PART NO. 2372-CLAMP)

## ELECTRONIC HEIGHT GAGE (LIGHT DUTY)

- Resolution .0005"/0.01mm
- Buttons: on/off, zero, inch/mm
- Automatic power off, move the digital unit to turn on power
- Carbide tipped scriber
- With fine adjustment
- Made of stainless steel
- Battery CR2032, data output
- Optional accessory: data output cable (part no. 7306-20, 7302-SPC5A/SPC5B, 7305-SPC2A, 7305-A01/A02), dial test indicator holder (part no. 7151-CL2)

Part No.	Range	Accuracy
1154-150	0-6"/0-150mm	±.0012"

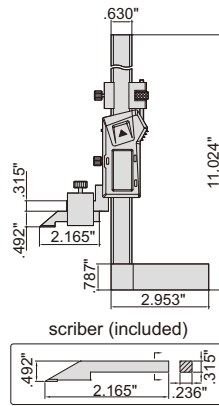

1154-150

dial test indicator holder (optional)

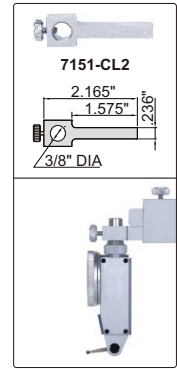

driving wheel on the back

- Dial indicator graduation .001"
- One counter reads in the plus direction and another in the minus direction, so incremental measurement can be made in either direction
- Carbide tipped scriber
- Made of stainless steel (except the base)
- With driving wheel
- Supplied with dust cover
- Optional accessory: dial test indicator holder (part no. 6293-7), clamp for protractors (part no. 2372-CLAMP)

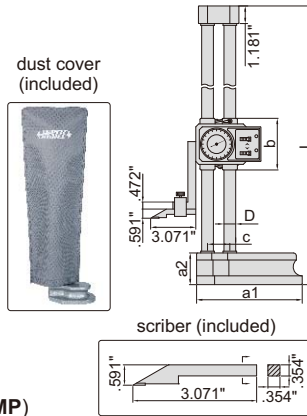

1351-12

## DIAL HEIGHT GAGES

dial test indicator holder (optional)

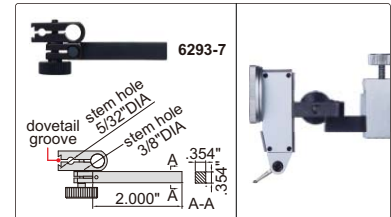

clamp for protractors (optional)

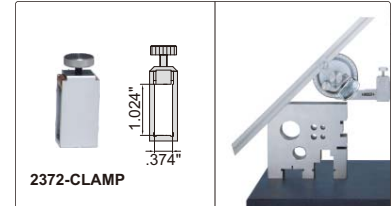

Part No.	Range	Accuracy	L	a1	a2	b	c	D
1351-12	0-12"	±.0016"	18.701"	5.315"	1.693"	3.307"	1.299"	.591" DIA
1351-18	0-18"	±.0020"	25.984"	7.087"	2.126"	3.465"	1.496"	.787" DIA
1351-24	0-24"	±.0020"	31.890"	7.087"	2.126"	3.465"	1.496"	.787" DIA

scriber (included)

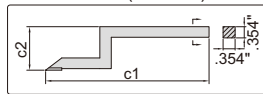

- Graduation .001"/0.02mm
- Adjustable main scale to set zero
- Carbide tipped scriber
- Made of stainless steel (except the base)
- Satin chrome plated scale
- Supplied with magnifier
- With fine adjustment
- Supplied with dust cover
- Optional accessory: dial test indicator holder (part no. 6293-7), clamp for protractors (part no. 2372-CLAMP)

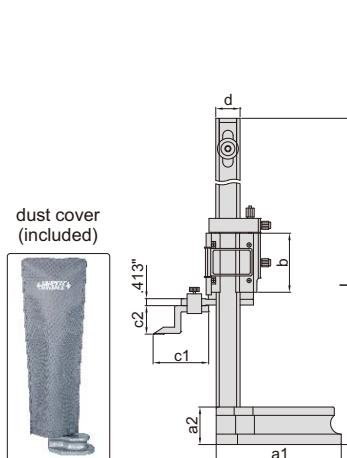

1250-300

Part No.	Range	Accuracy	L	a1	a2	b	c1	c2	d
1250-300	0-12"/0-300mm	±.0016"	21.457"	5.315"	1.693"	2.953"	3.150"	1.181"	1.102"
1250-450	0-18"/0-450mm	±.0020"	28.346"	7.087"	2.126"	3.346"	3.150"	1.614"	1.378"
1250-600	0-24"/0-600mm	±.0020"	34.252"	7.087"	2.126"	3.346"	3.150"	1.614"	1.378"

## VERNIER HEIGHT GAGES

dial test indicator holder (optional)

