

SERIES 46

THREAD RELIEF TOOLS

made from **ITI CARBIDE**

MIN BORE	FLAT WIDTH	OFFSET	MAX DEPTH	ORDER EDP#	TOOL IDENTIFICATION	SHANK
1/8	.060	.045	.300	46-1100	TR-125-300	1/8 X 2" O.A.L.
			.400	46-1105	TR-125-400	
3/16	.080	.060	.400	46-1110	TR-187-400	3/16 X 2-1/2 O.A.L.
			.800	46-1115	TR-187-800	
1/4	.095	.050	.500	46-1120	TR-250-500	1/4 X 2-1/2 O.A.L.
			1.000	46-1125	TR-250-1000	
5/16	.095	.080	.750	46-1130	TR-312-750	5/16 X 2-1/2 O.A.L.
			1.250	46-1135	TR-312-1250	
3/8	.130	.120	.750	46-1140	TR-375-750	3/8 X 2-1/2 O.A.L.
			1.250	46-1145	TR-375-1250	
1/2	.160	.130	1.000	46-1150	TR-500-1000	1/2 X 3" O.A.L.
			1.500	46-1155	TR-500-1500	

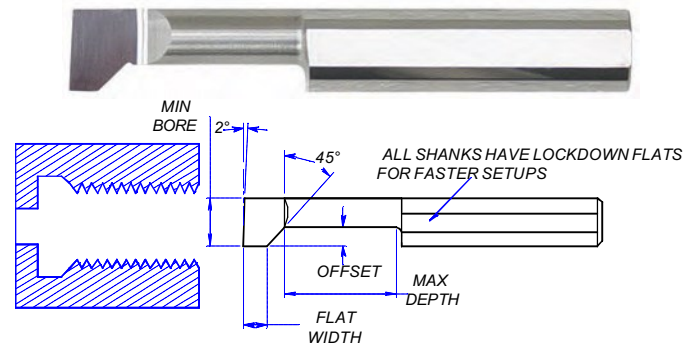

THREAD TOOLS

SERIES 08

made from **ITI CARBIDE**

APPLICATION : **MULTI-REACH THREADING**

MULTI-REACH THREADING TOOLS

NO LONGER LIMITED BY NECK LENGTH. ONE TOOL REPLACES A SERIES OF OTHERS.

MINIMUM BORE	TOOL I.D.	ORDER EDP#	ALTN EDP#	OFFSET	LARGEST PITCH	SHANK DIAMETER	SHANK LENGTH
.310	LT-310-4	08-1500	08-1500-C	.060	16	1/4"	4"
.375	LT-375-4	08-1505	08-1505-C	.060	16	5/16"	4"
.460	LT-460-6	08-1510	08-1510-C	.080	11	3/8"	6"
.610	LT-610-6	08-1515	08-1515-C	.100	9	1/2"	6"
.750	LT-750-6	08-1520	08-1520-C	.120	8	5/8"	6"

CARBIDE SHANKS PROVIDE MAXIMUM RIDGIDITY.



SERIES 42

QUICK CHANGE THREADING TOOLS

MINIMUM BORE	OFFSET	MAX DEPTH	ORDER EDP#	ALTN COATED EDP#
.060	.025	.200	42-3000	42-3000-C
		.300	42-3005	42-3005-C
.080	.025	.200	42-3010	42-3010-C
		.300	42-3015	42-3015-C
		.400	42-3020	42-3020-C
		.500	42-3025	42-3025-C
.100	.030	.200	42-3030	42-3030-C
		.300	42-3035	42-3035-C
		.400	42-3040	42-3040-C
.120	.035	.500	42-3045	42-3045-C
		.200	42-3050	42-3050-C
		.300	42-3055	42-3055-C
		.400	42-3060	42-3060-C
.140	.040	.500	42-3065	42-3065-C
		.200	42-3070	42-3070-C
		.300	42-3075	42-3075-C
.160	.045	.400	42-3080	42-3080-C
		.500	42-3085	42-3085-C
		.600	42-3090	42-3090-C
		.700	42-3095	42-3095-C

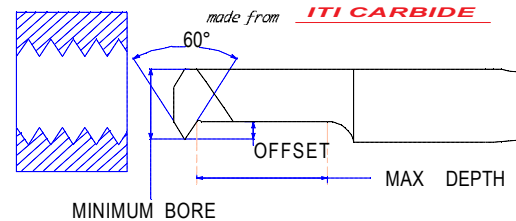

SEE HOLDERS ON PAGE 10

MINIMUM BORE	OFFSET	MAX DEPTH	ORDER EDP#	ALTN COATED EDP#
.160	.045	.200	42-3100	42-3100-C
		.300	42-3105	42-3105-C
		.400	42-3110	42-3110-C
		.500	42-3115	42-3115-C
		.600	42-3120	42-3120-C
.180	.045	.700	42-3125	42-3125-C
		.200	42-3130	42-3130-C
		.300	42-3135	42-3135-C
		.400	42-3140	42-3140-C
		.500	42-3145	42-3145-C
.180	.045	.600	42-3150	42-3150-C
		.700	42-3155	42-3155-C