

SERIES 49 *made from* **ITC CARBIDE**

APPLICATION : **DRILL & MILL WITH ONE TOOL.**

DRILL-MILLS

**CENTER CUTTING
30° RIGHT HAND HELIX
RIGHT HAND CUT**

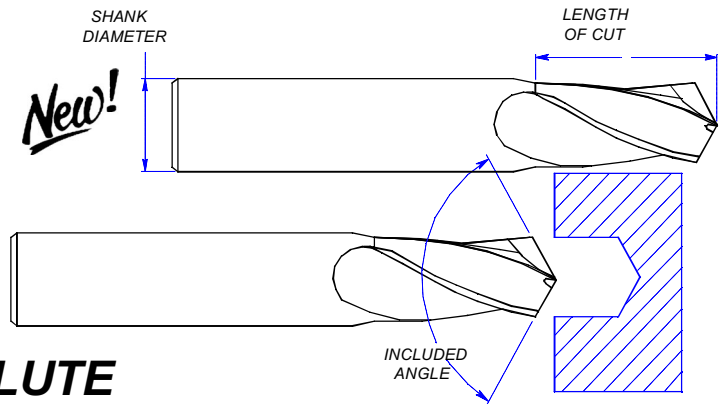

NOW AVAILABLE IN 2 AND 4 FLUTE

also available with altin coating simply add - C after the tool number when ordering

60° INCLUDED ANGLE

SIZE	4 FLUTE EDP #	2 FLUTE EDP #	LENGTH OF CUT	OVERALL LENGTH	SHANK DIAMETER
.125	49-1015	49-2015	5/8	2"	1/8
.187	49-1065	49-2065	3/4	2-1/2	3/16
.218	49-1115	49-2115	3/4	2-1/2	1/4
.250	49-1165	49-2165	1"	3"	1/4
.281	49-1215	49-2215	1"	3"	5/16
.312	49-1265	49-2265	1"	3"	5/16
.343	49-1315	49-2315	1"	3"	3/8
.375	49-1365	49-2365	1"	3"	3/8
.406	49-1415	49-2415	1"	3"	7/16
.437	49-1465	49-2465	1"	3"	7/16
.468	49-1515	49-2515	1"	3"	1/2
.500	49-1565	49-2565	1"	3"	1/2

82° INCLUDED ANGLE

SIZE	4 FLUTE EDP #	2 FLUTE EDP #	LENGTH OF CUT	OVERALL LENGTH	SHANK DIAMETER
.125	49-1010	49-2010	5/8	2"	1/8
.187	49-1060	49-2060	3/4	2-1/2	3/16
.218	49-1110	49-2110	3/4	2-1/2	1/4
.250	49-1160	49-2160	1"	3"	1/4
.281	49-1210	49-2210	1"	3"	5/16
.312	49-1260	49-2260	1"	3"	5/16
.343	49-1310	49-2310	1"	3"	3/8
.375	49-1360	49-2360	1"	3"	3/8
.406	49-1410	49-2410	1"	3"	7/16
.437	49-1460	49-2460	1"	3"	7/16
.468	49-1510	49-2510	1"	3"	1/2
.500	49-1560	49-2560	1"	3"	1/2

also available with altin coating simply add - C after the tool number when ordering

90° INCLUDED ANGLE

SIZE	4 FLUTE EDP #	2 FLUTE EDP #	LENGTH OF CUT	OVERALL LENGTH	SHANK DIAMETER
.125	49-1005	49-2005	5/8	2"	1/8
.187	49-1055	49-2055	3/4	2-1/2	3/16
.218	49-1105	49-2105	3/4	2-1/2	1/4
.250	49-1155	49-2155	1"	3"	1/4
.281	49-1205	49-2205	1"	3"	5/16
.312	49-1255	49-2255	1"	3"	5/16
.343	49-1305	49-2305	1"	3"	3/8
.375	49-1355	49-2355	1"	3"	3/8
.406	49-1405	49-2405	1"	3"	7/16
.437	49-1455	49-2455	1"	3"	7/16
.468	49-1505	49-2505	1"	3"	1/2
.500	49-1555	49-2555	1"	3"	1/2

120° INCLUDED ANGLE

SIZE	4 FLUTE EDP #	2 FLUTE EDP #	LENGTH OF CUT	OVERALL LENGTH	SHANK DIAMETER
.125	49-1000	49-2000	5/8	2"	1/8
.187	49-1050	49-2050	3/4	2-1/2	3/16
.218	49-1100	49-2100	3/4	2-1/2	1/4
.250	49-1150	49-2150	1"	3"	1/4
.281	49-1200	49-2200	1"	3"	5/16
.312	49-1250	49-2250	1"	3"	5/16
.343	49-1300	49-2300	1"	3"	3/8
.375	49-1350	49-2350	1"	3"	3/8
.406	49-1400	49-2400	1"	3"	7/16
.437	49-1450	49-2450	1"	3"	7/16
.468	49-1500	49-2500	1"	3"	1/2
.500	49-1550	49-2550	1"	3"	1/2