

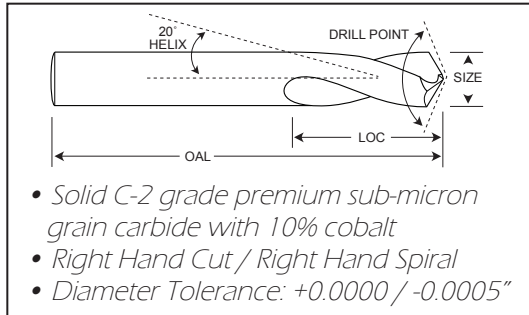

DRILL MONSTER N/C Spot Drill



Spotting Drills



- *Designed for exceptional precision & higher speeds and feeds*
- *Short flute & overall lengths provide superior rigidity*
- *Chamfers and centers in one operation*

DRILL MONSTER



SIZE	DECIMAL INCHES	LOC	OAL	UNCOATED	TiAIN Coated
1/8	0.1250	5/8	2	402-125090	402-125090B
3/16	0.1875	3/4	2	402-187090	402-187090B
1/4	0.2500	3/4	2-1/2	402-250090	402-250090B
5/16	0.3125	1	2-1/2	402-312090	402-312090B
3/8	0.3750	1	2-1/2	402-375090	402-375090B
1/2	0.5000	1-1/4	3	402-500090	402-500090B



SIZE	DECIMAL INCHES	LOC	OAL	UNCOATED	TiAIN Coated
1/8	0.1250	5/8	2	402-125120	402-125120B
3/16	0.1875	3/4	2	402-187120	402-187120B
1/4	0.2500	3/4	2-1/2	402-250120	402-250120B
5/16	0.3125	1	2-1/2	402-312120	402-312120B
3/8	0.3750	1	2-1/2	402-375120	402-375120B
1/2	0.5000	1-1/4	3	402-500120	402-500120B



SIZE	DECIMAL INCHES	LOC	OAL	UNCOATED	TiAIN Coated
1/8	0.1250	5/8	2	402-125140	402-125140B
3/16	0.1875	3/4	2	402-187140	402-187140B
1/4	0.2500	3/4	2-1/2	402-250140	402-250140B
5/16	0.3125	1	2-1/2	402-312140	402-312140B
3/8	0.3750	1	2-1/2	402-375140	402-375140B
1/2	0.5000	1-1/4	3	402-500140	402-500140B